



**ST. TAMMANY PARISH**

MICHAEL B. COOPER  
PARISH PRESIDENT

**NOTICE TO BIDDERS**

**ST. TAMMANY PARISH**

Sealed bids will be received by the Department of Procurement, until **2:00 p.m., Wednesday, May 3, 2023**, and then opened and read publicly at that time by the Procurement Staff for the following project:

**Bid # 23-20-2 – Utility Repair and Maintenance**

Each paper bid must be submitted in a sealed envelope. The outside of the envelope shall show the Name and Address of the Bidder, the State Contractor's License Number of the Bidder (if the work is estimated at \$50k or more), the Bid Name and the Bid Number.

**The project classification is:**

**Highway Street and Bridge Construction**

This bid package is available online at [www.bidexpress.com](http://www.bidexpress.com) or LaPAC

<https://wwwcfprd.doa.louisiana.gov/osp/lapac/dspBid.cfm?search=department&term=185>

It is the Vendor's responsibility to check Bid Express, or LaPAC frequently for any possible addenda that may be issued. The Parish is not responsible for a Vendor's failure to download any addenda documents required to complete a submission.

Bids will be received at 21454 Koop Dr., Suite 2F, Mandeville, LA 70471 from each bidder or his agent and given a written receipt, by certified mail with return receipt requested, or electronically at [www.bidexpress.com](http://www.bidexpress.com).

Procurement Department

# **BID PROPOSAL**

ST. TAMMANY PARISH  
GOVERNMENT



BID PACKAGE FOR

## **Utility Repair and Maintenance**

BID NO.: 23-20-2

March 15, 2023

## Section 01

### Table of Contents

Section 01	Table of Contents
Section 02	Instructions to Bidders
Section 03	Summary of Work
Section 04	LA Uniform Public Work Bid Form Unit Price Form
Section 05	Affidavits, Louisiana (Pursuant to LSA-R.S. 38:2224, 38:2227 and 38:2212.10)
Section 06	Insurance Requirements (OMITTED)
Section 07	Project Sign
Section 08	General Conditions
Section 09	Sample Corporate Resolution
Section 10	Sample Certificate of Insurance
Section 11	Sample Contract
Section 12	Sample Task Order
Section 13	Special Provisions
Section 14	Technical Specifications
Section 15	Sewer Standard Details
Section 16	Water Standard Details

## Section 02

### Instructions to Bidders

Bidders are urged to promptly review the requirements of this specification and submit questions for resolution as early as possible during the bid period. Questions or concerns must be submitted in writing to the Procurement Department no later than 2:00 CST seven (7) working days prior to the bid opening date. Otherwise, this will be construed as acceptance by the bidders that the intent of the specifications is clear and that competitive bids may be obtained as specified herein. Protests with regard to the specification documents will not be considered after bids are opened.

1. Bid security is required. Be sure that your bid includes such security as is necessary to meet Parish requirements and is properly signed. The bid must be fully completed. All applicable Louisiana license numbers must be affixed.
2. The Owner is the St. Tammany Parish Government (the “Parish”).
3. The terms “he/his” and “it/its” may be used interchangeably.
4. The terms “Owner,” the “Parish,” and “St. Tammany Parish” may be used interchangeably.
5. The successful Bidder understands the contract term is from the date of the award through December 31, 2027.
6. Bidder specifically understands that acknowledgment of the General Conditions is required. Bidder specifically understands that signature of receipt of the General Conditions is mandated. **The Bidder’s signature on the “Louisiana Uniform Public Work Bid Form” will serve as acknowledgment of the Bidder’s receipt and understanding of the General Conditions as well as any Supplementary Conditions.**
7. ***If any additional work is performed by the contractor without written approval by owner, the cost of the work will be borne by the contractor and will not be reimbursed by the Parish.***
8. **Only** the Louisiana Uniform Public Bid Form, the Unit Price Form (if necessary), the bid security, and written evidence of authority of person signing the bid shall be submitted on or before the bid opening time and date provided for in the Bid Documents. Necessary copies of the Louisiana Uniform Public Work Forms and Unit Price Forms (if necessary) will be furnished for Bidding. Bound sets of the Contract Documents are for Bidder's information and should not be used in submitting Bids.
9. All other documents and information required are to be submitted by the low Bidder within ten (10) days after the opening of the bids, and at the same time of day and location as given for the opening of the bids in the Bid Documents.
10. Each Bid must be submitted in a sealed envelope, unless submitted electronically. The outside of the envelope shall show the name and address of the Bidder, the State Contractor’s License Number of the Bidder (if work requires contractor’s license), and the Project name and the Bid number. In the case of an electronic bid proposal, a contractor may submit an authentic digital signature on the electronic bid proposal accompanied by the contractor's license number, Project name and the Bid number.
11. The price quoted for the Work shall be stated in words and figures on the Bid Form, and in figures only on the Unit Price Form. The price in the Bid shall include all costs necessary for the complete performance of the Work in full conformity with the conditions of the Contract Documents, and shall include all applicable Federal, State, Parish, Municipal or other taxes. The price bid for the items listed on the Unit Price Form will include the cost of all related items not listed, but which are normally required to do the type of Work bid.

12. The Bid shall be signed by the Bidder. The information required on the Louisiana Uniform Public Work Bid Form must be provided. Evidence of agency, corporate, or partnership authority is required and shall be provided in conformance with LSA-R.S. 38:2212(B).
13. Only a Contractor licensed by the State to do the type of Work as indicated on the Notice to Bidders can submit a Bid. The Bidder's signature on the Bid Form certifies that he holds an active license under the provisions of Chapter 24 of Louisiana Revised Statutes Title 37. Failure to be properly licensed constitutes authority for the Owner to reject the Bid.
14. Bidders shall not attach any conditions or provisions to the Bid. Any conditions or provisions so attached may, at the sole option of the Owner, cause rejection of the Bid.
15. A Bid Guarantee of five percent (5%) of the amount of the total Bid, including Alternates, must accompany the Proposal and, at the option of the Bidder, may be a cashier's check, certified check or a satisfactory Bid Bond. The Bid Guarantee must be attached to the Louisiana Uniform Public Work Bid Form. No Bid will be considered unless it is so guaranteed. Cashier's check or certified check must be made payable to the order of the Owner. Cash deposits will not be accepted. The Owner reserves the right to cash or deposit the cashier's check or certified check. Such guarantees shall be made payable to the Parish of St. Tammany. In accordance with LSA-R.S. 38:2218(C), if a bid bond is used, it shall be written by a surety or insurance company currently on the U.S. Department of the Treasury Financial Management Service list of approved bonding companies which is published annually in the Federal Register, or by a Louisiana domiciled insurance company with at least an A- rating in the latest printing of the A.M. Best's Key Rating Guide to write individual bonds up to ten percent of policyholders' surplus as shown in the A.M. Best's Key Rating Guide or by an insurance company in good standing licensed to write bid bonds which is either domiciled in Louisiana or owned by Louisiana residents. It is **not** required to be on any AIA form.
16. Bid securities of the three (3) lowest Bidders will be retained by the Owner until the Contract is executed or until final disposition is made of the Bids submitted. Bid securities of all other Bidders will be returned promptly after the canvas of Bids. Bids shall remain binding for forty-five (45) days after the date set for Bid Opening. The Parish shall act within the forty-five (45) days to award the contract to the lowest responsible bidder or reject all bids. However, the Parish and the lowest responsible bidder, by mutual written consent, may agree to extend the deadline for award by one or more extensions of thirty (30) calendar days. In the event the Owner issued the Letter of Award during this period, or any extension thereof, the Bid accepted shall continue to remain binding until the execution of the Contract.
17. A Proposal may be withdrawn at any time prior to the scheduled closing time for receipt of Bids, provided the request is in writing, executed by the Bidder or its duly authorized representative and is filed with the Owner prior to that time. When such a request is received, the Proposal will be returned to the Bidder unopened. A bid withdrawn under the provisions of LSA-R.S. 38:2214(C) cannot be resubmitted.
18. Written communications, over the signature of the Bidder, to modify Proposals will be accepted and the Proposal corrected in accordance therewith if received by the Owner prior to the scheduled closing time for receipt of Bids. Oral, telephonic or telegraphic Modifications will not be considered.
19. No oral interpretation obligating the Owner will be made to any Bidder as to the meaning of the Drawings, Specifications and Contract Documents. Every request for such an interpretation shall be made in writing and addressed and forwarded to the Owner. Inquiries received within seven (7) days prior to the day fixed for opening of the Bids may not be given consideration. Every interpretation made to the Bidder shall be in the form of an addendum to the Specifications. All such Addenda shall become part of the Contract Documents. Failure of the Owner to send or failure of Bidder to receive any such interpretation shall not relieve any Bidder from any obligation under this Bid as submitted without Modification. All Addenda shall be issued in accordance with the Public Bid Law, LSA-R.S. 38:2212(O).

20. The Owner reserves the right to reject any or all Bids for just cause in accordance with the Public Bid Law, LSA-R.S. 38:2214(B). Incomplete, informal, illegible, or unbalanced Bids may be rejected. Reasonable grounds for belief that any one Bidder is concerned directly or indirectly with more than one Bid will cause rejection of all Bids wherein such Bidder is concerned. If required, a Bidder shall furnish satisfactory evidence of its competence and ability to perform the Work stipulated in its Proposal. Incompetence will constitute cause for rejection. If the Parish determines that the bidder is not responsive or responsible for any reason whatsoever, the bid may be rejected in accordance with State law.
21. Contractor shall be liable without limitation to the Parish for any and all injury, death, damage, loss, destruction, damages, costs, fines, penalties, judgments, forfeitures, assessments, expenses (including attorney fees), obligations, and other liabilities of every name and description, which may occur or in any way arise out of any act or omission of Contractor, its owners, agents, employees, partners or subcontractors.
22. Upon notice of any claim, demand, suit, or cause of action against the Parish, alleged to arise out of or be related to this Contract, Contractor shall investigate, handle, respond to, provide defense for, and defend at its sole expense, even if the claim, demand, suit, or cause of action is groundless, false, or fraudulent. The Parish may, but is not required to, consult with or assist the Contractor, but this assistance shall not affect the Contractor's obligations, duties, and responsibilities under this section. Contractor shall obtain the Parish's written consent before entering into any settlement or dismissal.
23. It is understood and agreed that neither party can foresee the exigencies beyond the control of each party which arise by reason of an Act of God or force majeure; therefore, neither party shall be liable for any delay or failure in performance beyond its control resulting from an Act of God or force majeure. The Parish shall determine whether a delay or failure results from an Act of God or force majeure based on its review of all facts and circumstances. The parties shall use reasonable efforts, including but not limited to, use of continuation of operations plans (COOP), business continuity plans, and disaster recovery plans, to eliminate or minimize the effect of such events upon the performance of their respective duties under this Contract.
24. Contractor shall fully indemnify and hold harmless the Parish, without limitation, for any and all injury, death, damage, loss, destruction, damages, costs, fines, penalties, judgments, forfeitures, assessments, expenses (including attorney fees), obligations, and other liabilities of every name and description, which may occur or in any way arise out of any act or omission of Contractor, its owners, agents, employees, partners or subcontractors. The Contractor shall not indemnify for the portion of any loss or damage arising from the Parish's act or failure to act.
25. Contractor shall fully indemnify and hold harmless the Parish, without limitation, from and against damages, costs, fines, penalties, judgments, forfeitures, assessments, expenses (including attorney fees), obligations, and other liabilities in any action for infringement of any intellectual property right, including but not limited to, trademark, trade-secret, copyright, and patent rights.

When a dispute or claim arises relative to a real or anticipated infringement, the Contractor, at its sole expense, shall submit information and documentation, including formal patent attorney opinions, as required by the Parish.

If the use of the product, material, service, or any component thereof is enjoined for any reason or if the Contractor believes that it may be enjoined, Contractor, while ensuring appropriate migration and implementation, data integrity, and minimal delays of performance, shall at its sole expense and in the following order of precedence: (i) obtain for the Parish the right to continue using such product, material, service, or component thereof; (ii) modify the product, material, service, or component thereof so that it becomes a non-infringing product, material, or service of at least equal quality and performance; (iii) replace the product, material, service, or component thereof so that it becomes a non-infringing product, material, or service of at least equal quality and performance; or, (iv) provide the Parish monetary compensation for all payments made under the Contract related to the infringing product, material, service, or component, plus for all costs incurred

to procure and implement a non-infringing product, material, or service of at least equal quality and performance. Until this obligation has been satisfied, the Contractor remains in default.

The Contractor shall not be obligated to indemnify that portion of a claim or dispute based upon the Parish's unauthorized: i) modification or alteration of the product, material or service; ii) use of the product, material or service in combination with other products not furnished by Contractor; or, iii) use of the product, material or service in other than the specified operating conditions and environment.

26. Bidders shall familiarize themselves with and shall comply with all applicable Federal and State Laws, municipal ordinances and the rules and regulations of all authorities having jurisdiction over construction of the Project, which may directly or indirectly affect the Work or its prosecution. These laws and/or ordinances will be deemed to be included in the Contract, as though herein written in full.
27. Each Bidder shall visit the site of the proposed Work and fully acquaint itself with all surface and subsurface conditions as they may exist so that it may fully understand this Contract. Bidder shall also thoroughly examine and be familiar with drawings, Specifications and Contract Documents. The failure or omission of any Bidder to receive or examine any form, instrument, Drawing or document or to visit the site and acquaint itself with existing conditions shall in no way relieve any Bidder from any obligation with respect to its Bid and the responsibility in the premises.
28. The standard contract form enclosed with the Proposal documents is a prototype. It is enclosed with the Contract Documents for the guidance of the Owner and the Contractor. It has important legal consequences in all respects and consultation with an attorney is encouraged. Contractor shall be presumed to have consulted with its own independent legal counsel.
29. When one set of Contract plans show the Work to be performed by two or more prime Contractors, it is the responsibility of each Bidder to become knowledgeable of the Work to be performed by the other where the Work upon which this bid is submitted is shown to come into close proximity or in conflict with the Work of the other. In avoiding conflicts, pressure pipe lines must be installed to avoid conflict with gravity pipe lines and the Bidder of the smaller gravity pipe line in conflict with the larger gravity pipe line must include in his Bid the cost of a conflict box at these locations. The location of and a solution to the conflicts do not have to be specifically noted as such on the plans.
30. Bidder shall execute affidavit(s) attesting compliance with LSA-R.S. 38:2212.10, 38:2224, 38:2227, each as amended, and other affidavits as required by law, prior to execution of the contract.
31. Sealed Bids shall be delivered to St. Tammany Parish Government at the office of **St. Tammany Parish Government, Department of Procurement, 21454 Koop Drive, Suite 2-F, Mandeville, LA 70471**, and a receipt given, until the time and date denoted in Notice to Bidders, at which time and place the Bids shall be publicly opened and read aloud to those present. In accordance with LSA-R.S. 38:2212(H), the designer's final estimated cost of construction shall be read aloud upon opening bids. Sealed Bids may also be mailed by certified mail to **St. Tammany Parish Government, Department of Procurement, 21454 Koop Drive, Suite 2-F, Mandeville, LA 70471**, and must be received before the bid opening. Bids may also be submitted electronically. Information concerning links for electronic bidding is contained in the Notice to Bidders. It is the responsibility of the Bidders to ensure that bids are delivered in a timely fashion. **Late bids, regardless of reason, will not be considered, and will be returned to bidder.**

32. Paper bids shall be placed in a sealed envelope, marked plainly and prominently as indicated in the Notice to Bidders, and these Instructions, and addressed:

**St. Tammany Parish Government  
Department of Procurement  
21454 Koop Drive, Suite 2-F  
Mandeville, LA 70471**

33. See Notice to Bidders for availability of Drawings, Specifications and Contract Documents via electronic methods.
34. The successful Bidder shall be required to post in each direction a public information sign, 4' x 4' in size, at the location of the project containing information required by the Owner. The Owner shall supply this information.
35. The award of the Contract, if it is awarded, will be to the lowest responsible Bidder, in accordance with State Law. No award will be made until the Owner has concluded such investigations as it deems necessary to establish the responsibility and qualifications of the Bidder to do the Work in accordance with the Contract Documents to the satisfaction of the Owner within the time prescribed as established by the Department based upon the amount of work to be performed and the conditions of same. The written contract and bond shall be issued in conformance with LSA-R.S. 38:2216. If the Contract is awarded, the Owner shall give the successful Bidder written notice of the award within forty-five (45) calendar days after the opening of the Bids in conformance with LSA-R.S. 38:2215(A), or any extension as authorized thereunder.
36. At least three days prior to the execution of the Contract, the Contractor shall deliver to the Owner the required Bonds.
37. Failure of the successful Bidder to execute the Contract and deliver the required Bonds within ten (10) days of the Notice of the Award shall be just cause for the Owner to annul the award and declare the Bid and any guarantee thereof forfeited. Award may then be made to the next lowest responsible bidder.
38. In order to ensure the faithful performance of each and every condition, stipulation and requirement of the Contract and to indemnify and hold harmless the Owner from any and all damages, either directly or indirectly arising out of any failure to perform same, the successful Bidder to whom the Contract is awarded shall furnish a Performance and Payment Bond in an amount of at least equal to one hundred percent (100%) of the Contract Price. The Contract shall not be in force or binding upon the Owner until such satisfactory Bond has been provided to and approved by the Parish. The cost of the Bond shall be paid for by the Contractor unless otherwise stipulated in the Special Provisions.
39. No surety Company will be accepted as a bondsman which has no permanent agent or representative in the State upon whom notices referred to in the General Conditions of these Specifications may be served. Service of said notice on said agent or representative in the State shall be equal to service of notice on the President of the Surety Company, or such other officer as may be concerned.
40. In conformance with LSA-R.S. 38:2219(A)(1)(a), (b), and (c):

Any surety bond written for a public works project shall be written by a surety or insurance company currently on the U.S. Department of the Treasury Financial Management Service list of approved bonding companies which is published annually in the Federal Register, or by a Louisiana domiciled insurance company with at least an A- rating in the latest printing of the A.M. Best's Key Rating Guide, to write individual bonds up to ten percent of policyholders' surplus as shown in the A.M. Best's Key Rating Guide or by an insurance company that is either domiciled in Louisiana or owned by Louisiana residents and is licensed to write surety bonds.

For any public works project, no surety or insurance company shall write a bond which is in excess of the amount indicated as approved by the U.S. Department of



the Treasury Financial Management Service list or by a Louisiana domiciled insurance company with an A- rating by A.M. Best up to a limit of ten percent of policyholders' surplus as shown by A.M. Best; companies authorized by this Paragraph who are not on the treasury list shall not write a bond when the penalty exceeds fifteen percent of its capital and surplus, such capital and surplus being the amount by which the company's assets exceed its liabilities as reflected by the most recent financial statements filed by the company with the Department of Insurance.

In addition, any surety bond written for a public works project shall be written by a surety or insurance company that is currently licensed to do business in the state of Louisiana. All contractors must comply with any other applicable provisions of LSA-R.S. 38:2219.

41. Should the Contractor's Surety, even though approved and accepted by the Owner, subsequently remove its agency or representative from the State or become insolvent, bankrupt, or otherwise fail, the Contractor shall immediately furnish a new Bond in another company approved by the Owner, at no cost to the Owner. The new Bond shall be executed under the same terms and conditions as the original Bond. The new bond shall be submitted within thirty (30) days of such time as the Owner notifies Contractor or from the time Contractor learns or has reason to know that the original surety is no longer financially viable or acceptable to the Parish, whichever occurs first. In the event that Contractor fails or refuses to timely secure additional surety, then the Owner may secure such surety and thereafter deduct such cost or expense from any sum due, or to become due to Contractor.
42. The Contractor's bondsman shall obligate itself to all the terms and covenants of these Specifications and of contracts covering the Work executed hereunder. The Owner reserves the right to do Extra Work or make changes by altering, adding to deducting from the Work under the conditions and in the manner herein before described without notice to the Contractor's surety and without in any manner affecting the liability of bondsman or releasing it from any of its obligations hereunder.
43. The Bond shall also secure for the Owner the faithful performance of the Contract in strict accordance with plans, specifications, and other Contract Documents. It shall protect the Owner against all lien laws of the State and shall provide for payment of reasonable attorney's fees for enforcement of Contract and institution or concursus proceedings, if such proceedings become necessary. Likewise, it shall provide for all additional expenses of the Owner occurring through failure of the Contractor to perform.
44. The surety of the Contractor shall be and does hereby declare and acknowledge itself by acceptance to be bound to the Owner as a guarantor, jointly and in solido, with the Contractor, for fulfillment of terms of the Contract.
45. The performance Bond and Labor and Material Bond forming part of this Contract shall be continued by Contractor and its Surety for a period of one (1) year from date of acceptance of the Work/Project by Owner to assure prompt removal and replacement of all defective material, equipment, components thereof, workmanship, etc., and to assure payment of any damage to property of Owner or others as a result of such defective materials, equipment, workmanship, etc.
46. Contractor authorizes Parish to deduct from any payment due herein costs and service fees for recordation of this Contract in full or an excerpt hereof, or any revisions or modifications thereof as required by law. Contractor agrees to execute an excerpt or extract of this agreement for recordation purposes. If Contractor fails to execute such an excerpt, then the Parish shall file and record the entire Contract and all attachments at the expense of Contractor and Parish is hereby authorized to deduct all related costs from any proceeds due to the Contractor.
47. Contractor shall secure and maintain at its expense such insurance that will protect it and the Parish from claims for injuries to persons or damages to property which may arise from or in connection with the performance of Services or Work hereunder by the Contractor, his agents, representatives, employees, and/or subcontractors. The cost of such insurance shall be included in Contractor's bid.

48. The Contractor shall not commence work until it has obtained all insurance as required for the Parish Project. If the Contractor fails to furnish the Parish with the insurance protection required and begins work without first furnishing Parish with a currently dated certificate of insurance, the Parish has the right to obtain the insurance protection required and deduct the cost of insurance from the first payment due the Contractor. Further deductions are permitted from future payments as are needed to protect the interests of the Parish including, but not limited to, renewals of all policies.
49. Payment of Premiums: The insurance companies issuing the policy or policies shall have no recourse against the Parish of St. Tammany for payment of any premiums or for assessments under any form of policy.
50. Deductibles: Any and all deductibles in the described insurance policies shall be assumed by and be at the sole risk of the Contractor.
51. Authorization of Insurance Company(ies) and Rating: All insurance companies must be authorized to do business in the State of Louisiana and shall have an A.M. Best rating of no less than A-, Category VII.
52. Policy coverages and limits must be evidenced by Certificates of Insurance issued by Contractor's carrier to the Parish and shall reflect:

Date of Issue: Certificate must have current date.

Named Insured: The legal name of Contractor under contract with the Parish and its principal place of business shall be shown as the named insured on all Certificates of Liability Insurance.

Name of Certificate Holder: St. Tammany Parish Government, Office of Risk Management, P. O. Box 628, Covington, LA 70434

Project Description: A brief project description, including Project Name, Project Number and/or Contract Number, and Location.

Endorsements and Certificate Reference: All policies must be endorsed to provide, and certificates of insurance must evidence the following:

Waiver of Subrogation: The Contractor's insurers will have no right of recovery or subrogation against the Parish of St. Tammany, it being the intention of the parties that all insurance policy(ies) so affected shall protect both parties and be the primary coverage for any and all losses covered by the below described insurance. *Policy endorsements required for all coverages.*

Additional Insured: The Parish of St. Tammany shall be named as additional named insured with respect to general liability, marine liability, pollution/environmental liability, automobile liability and excess liability coverages. *Policy endorsements required.*

Hold Harmless: Contractor's liability insurers shall evidence their cognizance of the Hold Harmless and Indemnification in favor of St. Tammany Parish Government by referencing same on the face of the Certificate(s) of Insurance.

Cancellation Notice: Producer shall provide thirty (30) days prior written notice to the Parish of policy cancellation or substantive policy change.

53. The types of insurance coverage the Contractor is required to obtain and maintain throughout the duration of the Contract shall be designated by a separate document issued by the Office of Risk Management.

54. It is the intent of these instructions that they are in conformance with State Bid Laws. Should there be any discrepancy or ambiguity in these provisions, the applicable State Bid Law shall apply.
55. The letting of any public contract in connection with funds that are granted or advanced by the United States of America shall be subject to the effect, if any, of related laws of said United States and valid rules and regulations of federal agencies in charge, or governing use and payment of such federal funds.
56. Protests based on alleged solicitation improprieties that are apparent before bid opening, or the time set for receipt of initial proposals must be filed with and received by the Procurement Department BEFORE these times. Any other protest shall be filed no later than ten (10) calendar days after: the opening of the bid; the basis of the protest is known; or the basis of the protest should have been known (whichever is earlier).
57. It is the Parish's policy to provide a method to protest exclusion from a competition or from the award of a contract, or to challenge an alleged solicitation irregularity. It is always better to seek a resolution within the Parish system before resorting to outside agencies and/or litigation to resolve differences. All protests must be made in writing, and shall be concise and logically presented to facilitate review by the Parish. The written protest shall include:

The protester's name, address, and fax and telephone numbers and the solicitation, bid, or contract number;

A detailed statement of its legal and factual grounds, including a description of the resulting prejudice to the protester;

Copies of relevant documents;

All information establishing that the protester is an interested party and that the protest is timely; and

A request for a ruling by the agency; and a statement of the form of relief requested.

The protest shall be addressed to St. Tammany Parish Government Department of Procurement, P.O. Box 628, Covington, LA 70434

The protest review shall be conducted by the Parish Legal Department.

Only protests from interested parties will be allowed. Protests based on alleged solicitation improprieties that are apparent before bid opening, or the time set for receipt of initial proposals, must be filed with and received by the Department of Procurement BEFORE those deadlines.

Any other protest shall be filed no later than ten (10) calendar days after the basis of the protest is known, or should have been known (whichever is earlier).

The Parish will use its best efforts to resolve the protest within thirty (30) days of the date that it is received by the Parish. The written response will be sent to the protestor via mail and fax, if a fax number has been provided by the protestor. The protester can request additional methods of notification.

58. The last day to submit questions and/or verification on comparable products will be no later than 2:00 pm CST, seven (7) working days prior to the opening date of the bid/proposal due date. Further, any questions or inquires must be submitted via fax to 985-898-5227, or via email to [Procurement@stpgov.org](mailto:Procurement@stpgov.org). Any questions or inquiries received after the required deadline to submit questions or inquiries will not be answered.
59. St. Tammany Parish Government contracts to be awarded are dependent on the available funding and/or approval by members designated and/or acknowledged by St. Tammany

Parish Government. At any time, St. Tammany Parish Government reserves the right to cancel the award of a contract if either or both of these factors is deficient.

60. Any action by the Parish to disqualify any Bidder on the grounds that they are not a responsible Bidder shall be conducted in accordance with LSA-R.S. 38:2212(X).
61. Failure to complete or deliver within the time specified or to provide the services as specified in the bid or response will constitute a default and may cause cancellation of the contract. Where the Parish has determined the contractor to be in default. The Parish reserves the right to purchase any or all products or services covered by the contract on the open market and to charge the contractor with the cost in excess of the contract price. Until such assessed charges have been paid, no subsequent bid or response from the defaulting contractor will be considered.
62. If any part of the provisions contained herein and/or in the Specifications and Contract for the Work shall for any reason be held invalid, illegal or unenforceable in any respect, such invalidity, illegality or unenforceability shall not affect any other provisions of this Agreement or attachment, but it shall be construed as if such invalid, illegal, or unenforceable provision or part of a provision had never been contained herein.

## Section 03

### Summary of Work

#### I. Work to Include:

The work to be completed under this project consists of the Contractor furnishing all labor, equipment, and materials, and performing all work required as outlined below and described more specifically in Sections 13-16, provided the in package.

The work can be described as an annual utility repair and maintenance contract. It is intended for the Contractor to supplement work performed by regular maintenance personnel of the Department of Utilities. Types of work contemplated are listed on the bid form and specifications.

The quantities listed are just estimates. The Parish reserves the right to use more or less than the listed quantities.

All requests for equivalents must be submitted seven (7) business days prior to bid opening.

#### Scope of Work:

Contractor's services for Utility Repair and Maintenance are to be provided on an as-needed basis and as requested by issued Task Order or Emergency Response in the service areas of the Department of Utilities in unincorporated St. Tammany Parish. The Department of Utilities maintains approximately 1,000,000 linear feet of sewer main and 1,000,000 linear feet of water main ranging from 2" to 16" diameter in PVC, HDPE, Cementitious, and other materials. The work performed under this contract can be described as utility repair and maintenance for both water and sewer systems and consist of primarily point repairs, but also emergency services, and other work as required by the Department of Utilities. The total value of all work performed under this contract shall have an estimated minimum usage of \$250,000.00 and not exceed the amount of \$500,000.00. All work performed shall be based on the unit bid prices Attachment -A, which includes point repairs, emergency services, and other assigned work.

Point repairs and other assigned work shall typically occur during regular Parish business hours (7:30 am - 4:30 pm).

#### Emergency Work:

Emergency services can occur at any time including weekends and holidays. Emergency services shall be determined by the Director of the Department of Utilities or assignee, and shall only be utilized in the event of concern regarding health, safety, and welfare. If determined to be an Emergency Service, the Parish requires the contractor to appear on the project site within two (2) hours of being notified. Contractor shall supply sufficient manpower, equipment, and supplies necessary to begin work immediately, and complete work in a timely and professional manner.

Following completion of emergency service(s), Contractor shall prepare a detailed cost breakdown based on unit rates of bid showing applicable line items utilized for repair to submit to the Parish for review, approval, and processing. Detailed cost breakdown shall be submitted to the Parish within two (2) weeks of completing repair for Emergency Service.

Contractor will be requested to develop the scope and costs for assigned work and services utilizing the bid prices provided under this contract as shown on the attached Unit Price Form. It is possible that these projects and services will never

be constructed. The Contractor shall consider the time expended in developing the scope and costs for the proposed projects as the cost of doing business and shall not seek compensation for the time spent completing said proposals.

The Parish shall purchase only such items listed on the bid form, as needed. The Contract shall consist of various jobs (“Job”) throughout the contract term. The Job shall be the work described on any one-issued Task Order. Each Job shall be estimated as to the quantities and items required to complete the amount of work proposed with a minimum value of \$1,000.00 and not to exceed \$250,000.00. Any single Job meeting or exceeding the \$250,000.00 limit must be bid independently of this Contract. The estimated time for completion shall be in accordance with the size of the Job and shall be provided on each issued Task Order.

The Contractor will be required to commence work at a Job under the Contract within ten (10) calendar days after receipt of the Task Order by the Contractor unless otherwise agreed to in writing by the Parish. The Contractor shall complete the Job within the number of calendar days set in the Task Order for that Job. Failure to complete the work within the required period or failure to respond within required timeframes will be considered in authorizing additional work.

Each Task Order will be issued by letter with appropriate drawings or other attachments as necessary and will designate a Task Order number. All correspondence, billing, etc., pertaining to the work shall reference this Task Order number designation.

All utility work shall be done in accordance with St. Tammany Parish Government’s Department of Utilities Standard Details and Notes and as described more specifically in the BID solicitation. All work and materials shall conform to all applicable Federal, State, and local requirements and regulations governing public water and sewer systems, including but not limited to the State Sanitary Code. Additionally, all work and materials shall conform to the requirements of accepted industry standards, including but not limited to American Water Works Association (AWWA) standards, American National Standards Institute (ANSI) standards, and American Society for Testing and Materials (ASTM) standards. Contractor shall comply with all local, state, and federal laws and regulations including the Occupational Safety and Health Act (OSHA).

The initial term of the contract shall be the date the contract is signed and will end on December 31, 2023, with an option for four (4) additional one (1) year renewals, based upon the same terms and conditions of the initial term, by written agreement of both parties.

The schedule of contract items and unit prices provided in the bid proposal shall be used for the term of the contract. Either party may cancel the contract at the end of the first year with a minimum of ninety (90) days prior written notice, without assigning any reason by the Parish or the Contractor.

**II. Location of Work:**

All work shall be performed within St. Tammany Parish, Louisiana.

**III. Documents: Bid Documents dated 15 March 2023 and entitled:**

Utility Repair and Maintenance

BID No. 23-20-2

**IV. Other Requirements (as applicable)**

**All work and materials shall conform to all applicable Federal, State and local requirements and regulations governing public water and sewer systems, including but not limited to the State Sanitary Code. Additionally, all work**

**and materials shall conform the requirements of accepted industry standards, including but not limited to American Water Works Association (AWWA) standards, American National Standards Institute (ANSI) standards, American Society for Testing and Materials (ASTM) standards.**

**When not otherwise specified herein, all work and materials shall conform to the requirements of the Louisiana Department of Transportation and Development hereafter called LDOTD (2016 Edition of Louisiana Standard Specifications for Roads and Bridges).**

**Section 04**

**LOUISIANA UNIFORM PUBLIC WORK BID FORM**

**TO:** St. Tammany Parish Government  
21454 Koop Dr., Suite 2F  
Mandeville, La 70471

*(Owner to provide name and address of owner)*

**BID FOR:** Utility Repair and Maintenance  
BID No. 23-20-2

*(Owner to provide name of project and other identifying information.)*

The undersigned bidder hereby declares and represents that she/he; a) has carefully examined and understands the Bidding Documents, b) has not received, relied on, or based his bid on any verbal instructions contrary to the Bidding Documents or any addenda, c) has personally inspected and is familiar with the project site, and hereby proposes to provide all labor, materials, tools, appliances and facilities as required to perform, in a workmanlike manner, all work and services for the construction and completion of the referenced project, all in strict accordance with the Bidding Documents prepared by: St. Tammany Parish Government and dated: March 15, 2023.

*(Owner to provide name of entity preparing bidding documents.)*

Bidders must acknowledge all addenda. The Bidder acknowledges receipt of the following **ADDENDA:** (Enter the number the Designer has assigned to each of the addenda that the Bidder is acknowledging) \_\_\_\_\_.

**TOTAL BASE BID:** For all work required by the Bidding Documents (including any and all unit prices designated "Base Bid" \* but not alternates) the sum of:

\_\_\_\_\_ Dollars (\$ \_\_\_\_\_)

**ALTERNATES:** For any and all work required by the Bidding Documents for Alternates including any and all unit prices designated as alternates in the unit price description.

**Alternate No. 1** *(Owner to provide description of alternate and state whether add or deduct)* for the lump sum of:

N/A \_\_\_\_\_ Dollars (\$ \_\_\_\_\_)

**Alternate No. 2** *(Owner to provide description of alternate and state whether add or deduct)* for the lump sum of:

N/A \_\_\_\_\_ Dollars (\$ \_\_\_\_\_)

**Alternate No. 3** *(Owner to provide description of alternate and state whether add or deduct)* for the lump sum of:

N/A \_\_\_\_\_ Dollars (\$ \_\_\_\_\_)

**NAME OF BIDDER:** \_\_\_\_\_

**ADDRESS OF BIDDER:** \_\_\_\_\_

**LOUISIANA CONTRACTOR'S LICENSE NUMBER:** \_\_\_\_\_

**NAME OF AUTHORIZED SIGNATORY OF BIDDER:** \_\_\_\_\_

**TITLE OF AUTHORIZED SIGNATORY OF BIDDER:** \_\_\_\_\_

**SIGNATURE OF AUTHORIZED SIGNATORY OF BIDDER \*\*:** \_\_\_\_\_

**EMAIL:** \_\_\_\_\_

**DATE:** \_\_\_\_\_

**THE FOLLOWING ITEMS ARE TO BE INCLUDED WITH THE SUBMISSION OF THIS LOUISIANA UNIFORM PUBLIC WORK BID FORM:**

\* The Unit Price Form shall be used if the contract includes unit prices. Otherwise it is not required and need not be included with the form. The number of unit prices that may be included is not limited and additional sheets may be included if needed.

\*\* **A CORPORATE RESOLUTION OR WRITTEN EVIDENCE** of the authority of the person signing the bid for the public work as prescribed by LA R.S. 38:2212(B)(5).

**BID SECURITY** in the form of a bid bond, certified check or cashier's check as prescribed by LA R.S. 38:2218(A) attached to and made a part of this bid.

\*\*\* **W-9** – If a vendor has not done business with the Parish, the vendor should submit an updated W-9 with their response.



## LOUISIANA UNIFORM PUBLIC WORK BID FORM UNIT PRICE FORM

TO:

St. Tammany Parish Government  
 21454 Koop Drive, Suite 2F  
 Mandeville, LA. 70471

(OWNER TO PROVIDE NAME AND ADDRESS OF OWNER)

BID FOR:

Utility Repair and Maintenance

FOR: BID No. 23-20-2

(OWNER TO PROVIDE PROJECT NAME & OTHER IDENTIFYING INFO)

**UNIT PRICES:** This form shall be used for any & all work required by the Bidding Documents & described as unit prices. Amounts shall be stated in figures & only in figures.

<b>Description:</b> <input checked="" type="checkbox"/> BASE BID OR <input type="checkbox"/> ALT # 8" THICK OR GREATER PCCP, FIBER REINFORCED (IN-PLACE)				
<b>REF NO.:</b>	<b>QUANTITY</b>	<b>UNIT OF MEASURE</b>	<b>UNIT PRICE</b>	<b>UNIT PRICE EXTENSION (Quantity times unit price)</b>
101	1	SY		
<b>Description:</b> <input checked="" type="checkbox"/> BASE BID OR <input type="checkbox"/> ALT # 8" THICK OR GREATER PCCP, HIGH EARLY FIBER REINFORCED (IN-PLACE)				
<b>REF NO.:</b>	<b>QUANTITY</b>	<b>UNIT OF MEASURE</b>	<b>UNIT PRICE</b>	<b>UNIT PRICE EXTENSION (Quantity times unit price)</b>
102	1	SY		
<b>Description:</b> <input checked="" type="checkbox"/> BASE BID OR <input type="checkbox"/> ALT # PCC ROLL-OVER CURB W/ CURB DOWELS				
<b>REF NO.:</b>	<b>QUANTITY</b>	<b>UNIT OF MEASURE</b>	<b>UNIT PRICE</b>	<b>UNIT PRICE EXTENSION (Quantity times unit price)</b>
103	1	LF		
<b>Description:</b> <input checked="" type="checkbox"/> BASE BID OR <input type="checkbox"/> ALT # PCC BARRIER CURB W/ CURB DOWELS				
<b>REF NO.:</b>	<b>QUANTITY</b>	<b>UNIT OF MEASURE</b>	<b>UNIT PRICE</b>	<b>UNIT PRICE EXTENSION (Quantity times unit price)</b>
104	1	LF		

Wording for "description" is to be provided by the Owner. All Quantities Estimated. The Contractor will be paid based upon actual quantities as verified by the Owner.

**UNIT PRICES:** This form shall be used for any & all work required by the Bidding Documents & described as unit prices. Amounts shall be stated in figures & only in figures.

<b>Description:</b> <input checked="" type="checkbox"/> BASE BID OR <input type="checkbox"/> ALT # BITUMINOUS HOT MIX ASPHALT				
<b>REF NO.:</b>	<b>QUANTITY</b>	<b>UNIT OF MEASURE</b>	<b>UNIT PRICE</b>	<b>UNIT PRICE EXTENSION (Quantity times unit price)</b>
105	1	TON		
<b>Description:</b> <input checked="" type="checkbox"/> BASE BID OR <input type="checkbox"/> ALT # SAW CUT PAVEMENT				
<b>REF NO.:</b>	<b>QUANTITY</b>	<b>UNIT OF MEASURE</b>	<b>UNIT PRICE</b>	<b>UNIT PRICE EXTENSION (Quantity times unit price)</b>
106	1	IN/LF		
<b>Description:</b> <input checked="" type="checkbox"/> BASE BID OR <input type="checkbox"/> ALT # REMOVE AND RESTORE COMBINATION CONCRETE CURB AND GUTTER				
<b>REF NO.:</b>	<b>QUANTITY</b>	<b>UNIT OF MEASURE</b>	<b>UNIT PRICE</b>	<b>UNIT PRICE EXTENSION (Quantity times unit price)</b>
107	1	LF		
<b>Description:</b> <input checked="" type="checkbox"/> BASE BID OR <input type="checkbox"/> ALT # PCCP ROADWAY REMOVAL 6" THICK OR LESS				
<b>REF NO.:</b>	<b>QUANTITY</b>	<b>UNIT OF MEASURE</b>	<b>UNIT PRICE</b>	<b>UNIT PRICE EXTENSION (Quantity times unit price)</b>
108	1	SY		
<b>Description:</b> <input checked="" type="checkbox"/> BASE BID OR <input type="checkbox"/> ALT # PCCP ROADWAY REMOVAL GREATER THAN 6" THICK				
<b>REF NO.:</b>	<b>QUANTITY</b>	<b>UNIT OF MEASURE</b>	<b>UNIT PRICE</b>	<b>UNIT PRICE EXTENSION (Quantity times unit price)</b>
109	1	SY		
<b>Description:</b> <input checked="" type="checkbox"/> BASE BID OR <input type="checkbox"/> ALT # ASPHALT REMOVAL - 6" THICK OR LESS				
<b>REF NO.:</b>	<b>QUANTITY</b>	<b>UNIT OF MEASURE</b>	<b>UNIT PRICE</b>	<b>UNIT PRICE EXTENSION (Quantity times unit price)</b>
110	1	SY		

Version 2017 Q2

Wording for "description" is to be provided by the Owner. All Quantities Estimated. The Contractor will be paid based upon actual quantities as verified by the Owner.

**UNIT PRICES:** This form shall be used for any & all work required by the Bidding Documents & described as unit prices. Amounts shall be stated in figures & only in figures.

<b>Description:</b>	<input checked="" type="checkbox"/> BASE BID	OR	<input type="checkbox"/> ALT #	ASPHALT REMOVAL - GREATER THAN 6" THICK	
<b>REF NO.:</b>	<b>QUANTITY</b>	<b>UNIT OF MEASURE</b>	<b>UNIT PRICE</b>	<b>UNIT PRICE EXTENSION (Quantity times unit price)</b>	
111	1	SY			
<b>Description:</b>	<input checked="" type="checkbox"/> BASE BID	OR	<input type="checkbox"/> ALT #	FURNISH AND PLACE GRANULAR BASE COURSE	
<b>REF NO.:</b>	<b>QUANTITY</b>	<b>UNIT OF MEASURE</b>	<b>UNIT PRICE</b>	<b>UNIT PRICE EXTENSION (Quantity times unit price)</b>	
112	1	CY			
<b>Description:</b>	<input checked="" type="checkbox"/> BASE BID	OR	<input type="checkbox"/> ALT #	FURNISH AND PLACE LIMESTONE BASE COURSE	
<b>REF NO.:</b>	<b>QUANTITY</b>	<b>UNIT OF MEASURE</b>	<b>UNIT PRICE</b>	<b>UNIT PRICE EXTENSION (Quantity times unit price)</b>	
113	1	CY			
<b>Description:</b>	<input checked="" type="checkbox"/> BASE BID	OR	<input type="checkbox"/> ALT #	EMERGENCY CALL-OUT FOR SEWER AND WATER WORK	
<b>REF NO.:</b>	<b>QUANTITY</b>	<b>UNIT OF MEASURE</b>	<b>UNIT PRICE</b>	<b>UNIT PRICE EXTENSION (Quantity times unit price)</b>	
201	1	EA			
<b>Description:</b>	<input checked="" type="checkbox"/> BASE BID	OR	<input type="checkbox"/> ALT #	REMOVAL OF CONCRETE WALKS & DRIVES	
<b>REF NO.:</b>	<b>QUANTITY</b>	<b>UNIT OF MEASURE</b>	<b>UNIT PRICE</b>	<b>UNIT PRICE EXTENSION (Quantity times unit price)</b>	
202	1	SY			
<b>Description:</b>	<input checked="" type="checkbox"/> BASE BID	OR	<input type="checkbox"/> ALT #	FIBER REINFORCED 4" THICK PCC PAVING, IN PLACE FOR SIDEWALK	
<b>REF NO.:</b>	<b>QUANTITY</b>	<b>UNIT OF MEASURE</b>	<b>UNIT PRICE</b>	<b>UNIT PRICE EXTENSION (Quantity times unit price)</b>	
203	1	SY			

Version 2017-02  
Wording for "description" is to be provided by the Owner. All Quantities Estimated. The Contractor will be paid based upon actual quantities as verified by the Owner.

**UNIT PRICES:** This form shall be used for any & all work required by the Bidding Documents & described as unit prices. Amounts shall be stated in figures & only in figures.

<b>Description:</b> <input checked="" type="checkbox"/> BASE BID OR <input type="checkbox"/> ALT # FIBER REINFORCED 6" THICK PCC PAVING, IN PLACE FOR DRIVEWAYS (OR SIDEWALKS, IF SPECIFIED IN TASK ORDER)				
<b>REF NO.:</b>	<b>QUANTITY</b>	<b>UNIT OF MEASURE</b>	<b>UNIT PRICE</b>	<b>UNIT PRICE EXTENSION (Quantity times unit price)</b>
204	1	SY		
<b>Description:</b> <input checked="" type="checkbox"/> BASE BID OR <input type="checkbox"/> ALT # EXPLORATORY EXCAVATION				
<b>REF NO.:</b>	<b>QUANTITY</b>	<b>UNIT OF MEASURE</b>	<b>UNIT PRICE</b>	<b>UNIT PRICE EXTENSION (Quantity times unit price)</b>
205	1	EA		
<b>Description:</b> <input checked="" type="checkbox"/> BASE BID OR <input type="checkbox"/> ALT # WELL POINTING (INITIAL SET-UP)				
<b>REF NO.:</b>	<b>QUANTITY</b>	<b>UNIT OF MEASURE</b>	<b>UNIT PRICE</b>	<b>UNIT PRICE EXTENSION (Quantity times unit price)</b>
206	1	EA		
<b>Description:</b> <input checked="" type="checkbox"/> BASE BID OR <input type="checkbox"/> ALT # WELL POINT PUMPING PER EIGHT HOURS				
<b>REF NO.:</b>	<b>QUANTITY</b>	<b>UNIT OF MEASURE</b>	<b>UNIT PRICE</b>	<b>UNIT PRICE EXTENSION (Quantity times unit price)</b>
207	1	EA		
<b>Description:</b> <input checked="" type="checkbox"/> BASE BID OR <input type="checkbox"/> ALT # ST. AUGUSTINE GRASS SOD				
<b>REF NO.:</b>	<b>QUANTITY</b>	<b>UNIT OF MEASURE</b>	<b>UNIT PRICE</b>	<b>UNIT PRICE EXTENSION (Quantity times unit price)</b>
208	1	SY		
<b>Description:</b> <input checked="" type="checkbox"/> BASE BID OR <input type="checkbox"/> ALT # CENTIPEDE GRASS SOD				
<b>REF NO.:</b>	<b>QUANTITY</b>	<b>UNIT OF MEASURE</b>	<b>UNIT PRICE</b>	<b>UNIT PRICE EXTENSION (Quantity times unit price)</b>
209	1	SY		

Version 2017 Q2

**Wording for "description" is to be provided by the Owner. All Quantities Estimated. The Contractor will be paid based upon actual quantities as verified by the Owner.**

**UNIT PRICES:** This form shall be used for any & all work required by the Bidding Documents & described as unit prices. Amounts shall be stated in figures & only in figures.

<b>Description:</b> <input checked="" type="checkbox"/> BASE BID OR <input type="checkbox"/> ALT # SEED & FERTILIZE (CENTIPEDE)				
<b>REF NO.:</b>	<b>QUANTITY</b>	<b>UNIT OF MEASURE</b>	<b>UNIT PRICE</b>	<b>UNIT PRICE EXTENSION (Quantity times unit price)</b>
210	1	LB		
<b>Description:</b> <input checked="" type="checkbox"/> BASE BID OR <input type="checkbox"/> ALT # FURNISH & INSTALL/ TEST/ TAP SS SLEEVE – 4” X ALL SIZES				
<b>REF NO.:</b>	<b>QUANTITY</b>	<b>UNIT OF MEASURE</b>	<b>UNIT PRICE</b>	<b>UNIT PRICE EXTENSION (Quantity times unit price)</b>
211	1	EA		
<b>Description:</b> <input checked="" type="checkbox"/> BASE BID OR <input type="checkbox"/> ALT # FURNISH & INSTALL/ TEST/ TAP SS SLEEVE – 6” X ALL SIZES				
<b>REF NO.:</b>	<b>QUANTITY</b>	<b>UNIT OF MEASURE</b>	<b>UNIT PRICE</b>	<b>UNIT PRICE EXTENSION (Quantity times unit price)</b>
212	1	EA		
<b>Description:</b> <input checked="" type="checkbox"/> BASE BID OR <input type="checkbox"/> ALT # FURNISH & INSTALL/ TEST/ TAP SS SLEEVE – 8” X ALL SIZES				
<b>REF NO.:</b>	<b>QUANTITY</b>	<b>UNIT OF MEASURE</b>	<b>UNIT PRICE</b>	<b>UNIT PRICE EXTENSION (Quantity times unit price)</b>
213	1	EA		
<b>Description:</b> <input checked="" type="checkbox"/> BASE BID OR <input type="checkbox"/> ALT # FURNISH & INSTALL/ TEST/ TAP SS SLEEVE – 10” X ALL SIZES				
<b>REF NO.:</b>	<b>QUANTITY</b>	<b>UNIT OF MEASURE</b>	<b>UNIT PRICE</b>	<b>UNIT PRICE EXTENSION (Quantity times unit price)</b>
214	1	EA		
<b>Description:</b> <input checked="" type="checkbox"/> BASE BID OR <input type="checkbox"/> ALT # FURNISH & INSTALL/ TEST/ TAP SS SLEEVE – 12” X ALL SIZES				
<b>REF NO.:</b>	<b>QUANTITY</b>	<b>UNIT OF MEASURE</b>	<b>UNIT PRICE</b>	<b>UNIT PRICE EXTENSION (Quantity times unit price)</b>
215	1	EA		

Version 2017 Q2

Wording for "description" is to be provided by the Owner. All Quantities Estimated. The Contractor will be paid based upon actual quantities as verified by the Owner.

**UNIT PRICES:** This form shall be used for any & all work required by the Bidding Documents & described as unit prices. Amounts shall be stated in figures & only in figures.

<b>Description:</b>	<input checked="" type="checkbox"/> BASE BID	OR	<input type="checkbox"/> ALT #	FURNISH & INSTALL/ TEST/ TAP SS SLEEVE – 14” X ALL SIZES	
<b>REF NO.:</b>	<b>QUANTITY</b>	<b>UNIT OF MEASURE</b>	<b>UNIT PRICE</b>	<b>UNIT PRICE EXTENSION (Quantity times unit price)</b>	
216	1	EA			
<b>Description:</b>	<input checked="" type="checkbox"/> BASE BID	OR	<input type="checkbox"/> ALT #	FURNISH & INSTALL/ TEST/ TAP SS SLEEVE – 16” X ALL SIZES	
<b>REF NO.:</b>	<b>QUANTITY</b>	<b>UNIT OF MEASURE</b>	<b>UNIT PRICE</b>	<b>UNIT PRICE EXTENSION (Quantity times unit price)</b>	
217	1	EA			
<b>Description:</b>	<input checked="" type="checkbox"/> BASE BID	OR	<input type="checkbox"/> ALT #	FURNISH & INSTALL DUCTILE FITTINGS (ALL TYPES, ALL SIZES)	
<b>REF NO.:</b>	<b>QUANTITY</b>	<b>UNIT OF MEASURE</b>	<b>UNIT PRICE</b>	<b>UNIT PRICE EXTENSION (Quantity times unit price)</b>	
218	1	LB			
<b>Description:</b>	<input checked="" type="checkbox"/> BASE BID	OR	<input type="checkbox"/> ALT #	FURNISH & INSTALL PVC/ DUCTILE IRON MEGALUG RESTRAINTS	
<b>REF NO.:</b>	<b>QUANTITY</b>	<b>UNIT OF MEASURE</b>	<b>UNIT PRICE</b>	<b>UNIT PRICE EXTENSION (Quantity times unit price)</b>	
219	1	LB			
<b>Description:</b>	<input checked="" type="checkbox"/> BASE BID	OR	<input type="checkbox"/> ALT #	PIPE RESTRAINTS (3”) (WATER OR SEWER)	
<b>REF NO.:</b>	<b>QUANTITY</b>	<b>UNIT OF MEASURE</b>	<b>UNIT PRICE</b>	<b>UNIT PRICE EXTENSION (Quantity times unit price)</b>	
220	1	EA			
<b>Description:</b>	<input checked="" type="checkbox"/> BASE BID	OR	<input type="checkbox"/> ALT #	PIPE RESTRAINTS (4”) (WATER OR SEWER)	
<b>REF NO.:</b>	<b>QUANTITY</b>	<b>UNIT OF MEASURE</b>	<b>UNIT PRICE</b>	<b>UNIT PRICE EXTENSION (Quantity times unit price)</b>	
221	1	EA			

Version 2017-02  
Wording for "description" is to be provided by the Owner. All Quantities Estimated. The Contractor will be paid based upon actual quantities as verified by the Owner.

**UNIT PRICES:** This form shall be used for any & all work required by the Bidding Documents & described as unit prices. Amounts shall be stated in figures & only in figures.

<b>Description:</b> <input checked="" type="checkbox"/> BASE BID OR <input type="checkbox"/> ALT # PIPE RESTRAINTS (6") (WATER OR SEWER)				
<b>REF NO.:</b>	<b>QUANTITY</b>	<b>UNIT OF MEASURE</b>	<b>UNIT PRICE</b>	<b>UNIT PRICE EXTENSION (Quantity times unit price)</b>
222	1	EA		
<b>Description:</b> <input checked="" type="checkbox"/> BASE BID OR <input type="checkbox"/> ALT # PIPE RESTRAINTS (8") (WATER OR SEWER)				
<b>REF NO.:</b>	<b>QUANTITY</b>	<b>UNIT OF MEASURE</b>	<b>UNIT PRICE</b>	<b>UNIT PRICE EXTENSION (Quantity times unit price)</b>
223	1	EA		
<b>Description:</b> <input checked="" type="checkbox"/> BASE BID OR <input type="checkbox"/> ALT # PIPE RESTRAINTS (10") (WATER OR SEWER)				
<b>REF NO.:</b>	<b>QUANTITY</b>	<b>UNIT OF MEASURE</b>	<b>UNIT PRICE</b>	<b>UNIT PRICE EXTENSION (Quantity times unit price)</b>
224	1	EA		
<b>Description:</b> <input checked="" type="checkbox"/> BASE BID OR <input type="checkbox"/> ALT # PIPE RESTRAINTS (12") (WATER OR SEWER)				
<b>REF NO.:</b>	<b>QUANTITY</b>	<b>UNIT OF MEASURE</b>	<b>UNIT PRICE</b>	<b>UNIT PRICE EXTENSION (Quantity times unit price)</b>
225	1	EA		
<b>Description:</b> <input checked="" type="checkbox"/> BASE BID OR <input type="checkbox"/> ALT # PIPE RESTRAINTS (14") (WATER OR SEWER)				
<b>REF NO.:</b>	<b>QUANTITY</b>	<b>UNIT OF MEASURE</b>	<b>UNIT PRICE</b>	<b>UNIT PRICE EXTENSION (Quantity times unit price)</b>
226	1	EA		
<b>Description:</b> <input checked="" type="checkbox"/> BASE BID OR <input type="checkbox"/> ALT # PIPE RESTRAINTS (16") (WATER OR SEWER)				
<b>REF NO.:</b>	<b>QUANTITY</b>	<b>UNIT OF MEASURE</b>	<b>UNIT PRICE</b>	<b>UNIT PRICE EXTENSION (Quantity times unit price)</b>
227	1	EA		

Version 2017 Q2

**Wording for "description" is to be provided by the Owner. All Quantities Estimated. The Contractor will be paid based upon actual quantities as verified by the Owner.**

**UNIT PRICES:** This form shall be used for any & all work required by the Bidding Documents & described as unit prices. Amounts shall be stated in figures & only in figures.

<b>Description:</b> <input checked="" type="checkbox"/> BASE BID OR <input type="checkbox"/> ALT # REMOVAL OF EXISTING SEWER OR WATER PIPES				
<b>REF NO.:</b>	<b>QUANTITY</b>	<b>UNIT OF MEASURE</b>	<b>UNIT PRICE</b>	<b>UNIT PRICE EXTENSION (Quantity times unit price)</b>
228	1	LF		
<b>Description:</b> <input checked="" type="checkbox"/> BASE BID OR <input type="checkbox"/> ALT # FLOWABLE FILL GROUT				
<b>REF NO.:</b>	<b>QUANTITY</b>	<b>UNIT OF MEASURE</b>	<b>UNIT PRICE</b>	<b>UNIT PRICE EXTENSION (Quantity times unit price)</b>
229	1	CY		
<b>Description:</b> <input checked="" type="checkbox"/> BASE BID OR <input type="checkbox"/> ALT # SEWER POINT REPAIR (2" TO 4" PIPE) (DEPTH 0'-6')				
<b>REF NO.:</b>	<b>QUANTITY</b>	<b>UNIT OF MEASURE</b>	<b>UNIT PRICE</b>	<b>UNIT PRICE EXTENSION (Quantity times unit price)</b>
301	1	EA		
<b>Description:</b> <input checked="" type="checkbox"/> BASE BID OR <input type="checkbox"/> ALT # SEWER POINT REPAIR (2" TO 4" PIPE) (DEPTH 6.1'-10')				
<b>REF NO.:</b>	<b>QUANTITY</b>	<b>UNIT OF MEASURE</b>	<b>UNIT PRICE</b>	<b>UNIT PRICE EXTENSION (Quantity times unit price)</b>
302	1	EA		
<b>Description:</b> <input checked="" type="checkbox"/> BASE BID OR <input type="checkbox"/> ALT # SEWER POINT REPAIR (2" TO 4" PIPE) (DEPTH 10.1'-12')				
<b>REF NO.:</b>	<b>QUANTITY</b>	<b>UNIT OF MEASURE</b>	<b>UNIT PRICE</b>	<b>UNIT PRICE EXTENSION (Quantity times unit price)</b>
303	1	EA		
<b>Description:</b> <input checked="" type="checkbox"/> BASE BID OR <input type="checkbox"/> ALT # SEWER POINT REPAIR (2" TO 4" PIPE) (DEPTH >12')				
<b>REF NO.:</b>	<b>QUANTITY</b>	<b>UNIT OF MEASURE</b>	<b>UNIT PRICE</b>	<b>UNIT PRICE EXTENSION (Quantity times unit price)</b>
304	1	EA		

Version 2017 Q2

Wording for "description" is to be provided by the Owner. All Quantities Estimated. The Contractor will be paid based upon actual quantities as verified by the Owner.



**UNIT PRICES:** This form shall be used for any & all work required by the Bidding Documents & described as unit prices. Amounts shall be stated in figures & only in figures.

<b>Description:</b> <input checked="" type="checkbox"/> BASE BID OR <input type="checkbox"/> ALT # SEWER POINT REPAIR (6" & 8" PIPE) (DEPTH 0'-6')				
<b>REF NO.:</b>	<b>QUANTITY</b>	<b>UNIT OF MEASURE</b>	<b>UNIT PRICE</b>	<b>UNIT PRICE EXTENSION (Quantity times unit price)</b>
305	1	EA		
<b>Description:</b> <input checked="" type="checkbox"/> BASE BID OR <input type="checkbox"/> ALT # SEWER POINT REPAIR (6" & 8" PIPE) (DEPTH 6.1'-10')				
<b>REF NO.:</b>	<b>QUANTITY</b>	<b>UNIT OF MEASURE</b>	<b>UNIT PRICE</b>	<b>UNIT PRICE EXTENSION (Quantity times unit price)</b>
306	1	EA		
<b>Description:</b> <input checked="" type="checkbox"/> BASE BID OR <input type="checkbox"/> ALT # SEWER POINT REPAIR (6" & 8" PIPE) (DEPTH 10.1'-12')				
<b>REF NO.:</b>	<b>QUANTITY</b>	<b>UNIT OF MEASURE</b>	<b>UNIT PRICE</b>	<b>UNIT PRICE EXTENSION (Quantity times unit price)</b>
307	1	EA		
<b>Description:</b> <input checked="" type="checkbox"/> BASE BID OR <input type="checkbox"/> ALT # SEWER POINT REPAIR (6" & 8" PIPE) (DEPTH >12')				
<b>REF NO.:</b>	<b>QUANTITY</b>	<b>UNIT OF MEASURE</b>	<b>UNIT PRICE</b>	<b>UNIT PRICE EXTENSION (Quantity times unit price)</b>
308	1	EA		
<b>Description:</b> <input checked="" type="checkbox"/> BASE BID OR <input type="checkbox"/> ALT # SEWER POINT REPAIR (10" & 12" PIPE) (DEPTH 0'-6')				
<b>REF NO.:</b>	<b>QUANTITY</b>	<b>UNIT OF MEASURE</b>	<b>UNIT PRICE</b>	<b>UNIT PRICE EXTENSION (Quantity times unit price)</b>
309	1	EA		
<b>Description:</b> <input checked="" type="checkbox"/> BASE BID OR <input type="checkbox"/> ALT # SEWER POINT REPAIR (10" & 12" PIPE) (DEPTH 6.1'-10')				
<b>REF NO.:</b>	<b>QUANTITY</b>	<b>UNIT OF MEASURE</b>	<b>UNIT PRICE</b>	<b>UNIT PRICE EXTENSION (Quantity times unit price)</b>
310	1	EA		

Version 2017 Q2

Wording for "description" is to be provided by the Owner. All Quantities Estimated. The Contractor will be paid based upon actual quantities as verified by the Owner.

**UNIT PRICES:** This form shall be used for any & all work required by the Bidding Documents & described as unit prices. Amounts shall be stated in figures & only in figures.

<b>Description:</b> <input checked="" type="checkbox"/> BASE BID OR <input type="checkbox"/> ALT # SEWER POINT REPAIR (10" & 12" PIPE) (DEPTH 10.1'-12')				
<b>REF NO.:</b>	<b>QUANTITY</b>	<b>UNIT OF MEASURE</b>	<b>UNIT PRICE</b>	<b>UNIT PRICE EXTENSION (Quantity times unit price)</b>
311	1	EA		
<b>Description:</b> <input checked="" type="checkbox"/> BASE BID OR <input type="checkbox"/> ALT # SEWER POINT REPAIR (10" & 12" PIPE) (DEPTH >12')				
<b>REF NO.:</b>	<b>QUANTITY</b>	<b>UNIT OF MEASURE</b>	<b>UNIT PRICE</b>	<b>UNIT PRICE EXTENSION (Quantity times unit price)</b>
312	1	EA		
<b>Description:</b> <input checked="" type="checkbox"/> BASE BID OR <input type="checkbox"/> ALT # SEWER POINT REPAIR (14" TO 18" PIPE) (DEPTH 0'-6')				
<b>REF NO.:</b>	<b>QUANTITY</b>	<b>UNIT OF MEASURE</b>	<b>UNIT PRICE</b>	<b>UNIT PRICE EXTENSION (Quantity times unit price)</b>
313	1	EA		
<b>Description:</b> <input checked="" type="checkbox"/> BASE BID OR <input type="checkbox"/> ALT # SEWER POINT REPAIR (14" TO 18" PIPE) (DEPTH 6.1'-10')				
<b>REF NO.:</b>	<b>QUANTITY</b>	<b>UNIT OF MEASURE</b>	<b>UNIT PRICE</b>	<b>UNIT PRICE EXTENSION (Quantity times unit price)</b>
314	1	EA		
<b>Description:</b> <input checked="" type="checkbox"/> BASE BID OR <input type="checkbox"/> ALT # SEWER POINT REPAIR (14" TO 18" PIPE) (DEPTH 10.1'-12')				
<b>REF NO.:</b>	<b>QUANTITY</b>	<b>UNIT OF MEASURE</b>	<b>UNIT PRICE</b>	<b>UNIT PRICE EXTENSION (Quantity times unit price)</b>
315	1	EA		
<b>Description:</b> <input checked="" type="checkbox"/> BASE BID OR <input type="checkbox"/> ALT # SEWER POINT REPAIR (14" TO 18" PIPE) (DEPTH >12')				
<b>REF NO.:</b>	<b>QUANTITY</b>	<b>UNIT OF MEASURE</b>	<b>UNIT PRICE</b>	<b>UNIT PRICE EXTENSION (Quantity times unit price)</b>
316	1	EA		

Version 2017-02

Wording for "description" is to be provided by the Owner. All Quantities Estimated. The Contractor will be paid based upon actual quantities as verified by the Owner.

**UNIT PRICES:** This form shall be used for any & all work required by the Bidding Documents & described as unit prices. Amounts shall be stated in figures & only in figures.

<b>Description:</b> <input checked="" type="checkbox"/> BASE BID OR <input type="checkbox"/> ALT # GRAVITY SEWER PIPE 8-INCH (PVC, SDR 26) (0'-6' DEPTH)				
<b>REF NO.:</b>	<b>QUANTITY</b>	<b>UNIT OF MEASURE</b>	<b>UNIT PRICE</b>	<b>UNIT PRICE EXTENSION (Quantity times unit price)</b>
317	1	LF		
<b>Description:</b> <input checked="" type="checkbox"/> BASE BID OR <input type="checkbox"/> ALT # GRAVITY SEWER PIPE 8-INCH (PVC, SDR 26) (6.1'-10' DEPTH)				
<b>REF NO.:</b>	<b>QUANTITY</b>	<b>UNIT OF MEASURE</b>	<b>UNIT PRICE</b>	<b>UNIT PRICE EXTENSION (Quantity times unit price)</b>
318	1	LF		
<b>Description:</b> <input checked="" type="checkbox"/> BASE BID OR <input type="checkbox"/> ALT # GRAVITY SEWER PIPE 8-INCH (PVC, SDR 26) (10.1'-12' DEPTH)				
<b>REF NO.:</b>	<b>QUANTITY</b>	<b>UNIT OF MEASURE</b>	<b>UNIT PRICE</b>	<b>UNIT PRICE EXTENSION (Quantity times unit price)</b>
319	1	LF		
<b>Description:</b> <input checked="" type="checkbox"/> BASE BID OR <input type="checkbox"/> ALT # GRAVITY SEWER PIPE 8-INCH (PVC, SDR 26) (>12' DEPTH)				
<b>REF NO.:</b>	<b>QUANTITY</b>	<b>UNIT OF MEASURE</b>	<b>UNIT PRICE</b>	<b>UNIT PRICE EXTENSION (Quantity times unit price)</b>
320	1	LF		
<b>Description:</b> <input checked="" type="checkbox"/> BASE BID OR <input type="checkbox"/> ALT # GRAVITY SEWER PIPE 10-INCH (PVC, SDR 26) (0'-6' DEPTH)				
<b>REF NO.:</b>	<b>QUANTITY</b>	<b>UNIT OF MEASURE</b>	<b>UNIT PRICE</b>	<b>UNIT PRICE EXTENSION (Quantity times unit price)</b>
321	1	LF		
<b>Description:</b> <input checked="" type="checkbox"/> BASE BID OR <input type="checkbox"/> ALT # GRAVITY SEWER PIPE 10-INCH (PVC, SDR 26) (6.1'-10' DEPTH)				
<b>REF NO.:</b>	<b>QUANTITY</b>	<b>UNIT OF MEASURE</b>	<b>UNIT PRICE</b>	<b>UNIT PRICE EXTENSION (Quantity times unit price)</b>
322	1	LF		

Version 2017 Q2

Wording for "description" is to be provided by the Owner. All Quantities Estimated. The Contractor will be paid based upon actual quantities as verified by the Owner.

**UNIT PRICES:** This form shall be used for any & all work required by the Bidding Documents & described as unit prices. Amounts shall be stated in figures & only in figures.

<b>Description:</b> <input checked="" type="checkbox"/> BASE BID OR <input type="checkbox"/> ALT # GRAVITY SEWER PIPE 10-INCH (PVC, SDR 26) (10.1'-12' DEPTH)				
<b>REF NO.:</b>	<b>QUANTITY</b>	<b>UNIT OF MEASURE</b>	<b>UNIT PRICE</b>	<b>UNIT PRICE EXTENSION (Quantity times unit price)</b>
323	1	LF		
<b>Description:</b> <input checked="" type="checkbox"/> BASE BID OR <input type="checkbox"/> ALT # GRAVITY SEWER PIPE 10-INCH (PVC, SDR 26) (>12' DEPTH)				
<b>REF NO.:</b>	<b>QUANTITY</b>	<b>UNIT OF MEASURE</b>	<b>UNIT PRICE</b>	<b>UNIT PRICE EXTENSION (Quantity times unit price)</b>
324	1	LF		
<b>Description:</b> <input checked="" type="checkbox"/> BASE BID OR <input type="checkbox"/> ALT # GRAVITY SEWER PIPE 12-INCH (PVC, SDR 26) (0'-6' DEPTH)				
<b>REF NO.:</b>	<b>QUANTITY</b>	<b>UNIT OF MEASURE</b>	<b>UNIT PRICE</b>	<b>UNIT PRICE EXTENSION (Quantity times unit price)</b>
325	1	LF		
<b>Description:</b> <input checked="" type="checkbox"/> BASE BID OR <input type="checkbox"/> ALT # GRAVITY SEWER PIPE 12-INCH (PVC, SDR 26) (6.1'-10' DEPTH)				
<b>REF NO.:</b>	<b>QUANTITY</b>	<b>UNIT OF MEASURE</b>	<b>UNIT PRICE</b>	<b>UNIT PRICE EXTENSION (Quantity times unit price)</b>
326	1	LF		
<b>Description:</b> <input checked="" type="checkbox"/> BASE BID OR <input type="checkbox"/> ALT # GRAVITY SEWER PIPE 12-INCH (PVC, SDR 26) (10.1'-12' DEPTH)				
<b>REF NO.:</b>	<b>QUANTITY</b>	<b>UNIT OF MEASURE</b>	<b>UNIT PRICE</b>	<b>UNIT PRICE EXTENSION (Quantity times unit price)</b>
327	1	LF		
<b>Description:</b> <input checked="" type="checkbox"/> BASE BID OR <input type="checkbox"/> ALT # GRAVITY SEWER PIPE 12-INCH (PVC, SDR 26) (>12' DEPTH) <input type="checkbox"/>				
<b>REF NO.:</b>	<b>QUANTITY</b>	<b>UNIT OF MEASURE</b>	<b>UNIT PRICE</b>	<b>UNIT PRICE EXTENSION (Quantity times unit price)</b>
328	1	LF		

Version 2017.02

Wording for "description" is to be provided by the Owner. All Quantities Estimated. The Contractor will be paid based upon actual quantities as verified by the Owner.

**UNIT PRICES:** This form shall be used for any & all work required by the Bidding Documents & described as unit prices. Amounts shall be stated in figures & only in figures.

<b>Description:</b> <input checked="" type="checkbox"/> BASE BID OR <input type="checkbox"/> ALT # FURNISH & INSTALL 2" SEWER FORCE MAIN (PVC, SDR 26)				
<b>REF NO.:</b>	<b>QUANTITY</b>	<b>UNIT OF MEASURE</b>	<b>UNIT PRICE</b>	<b>UNIT PRICE EXTENSION (Quantity times unit price)</b>
329	1	LF		
<b>Description:</b> <input checked="" type="checkbox"/> BASE BID OR <input type="checkbox"/> ALT # FURNISH & INSTALL 3" SEWER FORCE MAIN (PVC, SDR 26)				
<b>REF NO.:</b>	<b>QUANTITY</b>	<b>UNIT OF MEASURE</b>	<b>UNIT PRICE</b>	<b>UNIT PRICE EXTENSION (Quantity times unit price)</b>
330	1	LF		
<b>Description:</b> <input checked="" type="checkbox"/> BASE BID OR <input type="checkbox"/> ALT # FURNISH & INSTALL 4" SEWER FORCE MAIN (PVC, C900 DR18)				
<b>REF NO.:</b>	<b>QUANTITY</b>	<b>UNIT OF MEASURE</b>	<b>UNIT PRICE</b>	<b>UNIT PRICE EXTENSION (Quantity times unit price)</b>
331	1	LF		
<b>Description:</b> <input checked="" type="checkbox"/> BASE BID OR <input type="checkbox"/> ALT # FURNISH & INSTALL 6" SEWER FORCE MAIN (PVC, C900 DR18)				
<b>REF NO.:</b>	<b>QUANTITY</b>	<b>UNIT OF MEASURE</b>	<b>UNIT PRICE</b>	<b>UNIT PRICE EXTENSION (Quantity times unit price)</b>
332	1	LF		
<b>Description:</b> <input checked="" type="checkbox"/> BASE BID OR <input type="checkbox"/> ALT # FURNISH & INSTALL 8" SEWER FORCE MAIN (PVC, C900 DR18)				
<b>REF NO.:</b>	<b>QUANTITY</b>	<b>UNIT OF MEASURE</b>	<b>UNIT PRICE</b>	<b>UNIT PRICE EXTENSION (Quantity times unit price)</b>
333	1	LF		
<b>Description:</b> <input checked="" type="checkbox"/> BASE BID OR <input type="checkbox"/> ALT # FURNISH & INSTALL 10" SEWER FORCE MAIN (PVC, C900 DR18)				
<b>REF NO.:</b>	<b>QUANTITY</b>	<b>UNIT OF MEASURE</b>	<b>UNIT PRICE</b>	<b>UNIT PRICE EXTENSION (Quantity times unit price)</b>
334	1	LF		

Wording for "description" is to be provided by the Owner. All Quantities Estimated. The Contractor will be paid based upon actual quantities as verified by the Owner.

**UNIT PRICES:** This form shall be used for any & all work required by the Bidding Documents & described as unit prices. Amounts shall be stated in figures & only in figures.

<b>Description:</b> <input checked="" type="checkbox"/> BASE BID OR <input type="checkbox"/> ALT # FURNISH & INSTALL 12" SEWER FORCE MAIN (PVC, C900 DR18)				
<b>REF NO.:</b>	<b>QUANTITY</b>	<b>UNIT OF MEASURE</b>	<b>UNIT PRICE</b>	<b>UNIT PRICE EXTENSION (Quantity times unit price)</b>
335	1	LF		
<b>Description:</b> <input checked="" type="checkbox"/> BASE BID OR <input type="checkbox"/> ALT # FURNISH & INSTALL 14" SEWER FORCE MAIN (PVC, C900 DR18)				
<b>REF NO.:</b>	<b>QUANTITY</b>	<b>UNIT OF MEASURE</b>	<b>UNIT PRICE</b>	<b>UNIT PRICE EXTENSION (Quantity times unit price)</b>
336	1	LF		
<b>Description:</b> <input checked="" type="checkbox"/> BASE BID OR <input type="checkbox"/> ALT # FURNISH & INSTALL 16" SEWER FORCE MAIN (PVC, C900 DR18)				
<b>REF NO.:</b>	<b>QUANTITY</b>	<b>UNIT OF MEASURE</b>	<b>UNIT PRICE</b>	<b>UNIT PRICE EXTENSION (Quantity times unit price)</b>
337	1	LF		
<b>Description:</b> <input checked="" type="checkbox"/> BASE BID OR <input type="checkbox"/> ALT # DIRECTIONAL DRILL 2" SEWER FORCE MAIN (HPDE DR-11)				
<b>REF NO.:</b>	<b>QUANTITY</b>	<b>UNIT OF MEASURE</b>	<b>UNIT PRICE</b>	<b>UNIT PRICE EXTENSION (Quantity times unit price)</b>
338	1	LF		
<b>Description:</b> <input checked="" type="checkbox"/> BASE BID OR <input type="checkbox"/> ALT # DIRECTIONAL DRILL 3" SEWER FORCE MAIN (HPDE DR-11)				
<b>REF NO.:</b>	<b>QUANTITY</b>	<b>UNIT OF MEASURE</b>	<b>UNIT PRICE</b>	<b>UNIT PRICE EXTENSION (Quantity times unit price)</b>
339	1	LF		
<b>Description:</b> <input checked="" type="checkbox"/> BASE BID OR <input type="checkbox"/> ALT # DIRECTIONAL DRILL 4" SEWER FORCE MAIN (HPDE DR-11)				
<b>REF NO.:</b>	<b>QUANTITY</b>	<b>UNIT OF MEASURE</b>	<b>UNIT PRICE</b>	<b>UNIT PRICE EXTENSION (Quantity times unit price)</b>
340	1	LF		

Version 2017 Q2

Wording for "description" is to be provided by the Owner. All Quantities Estimated. The Contractor will be paid based upon actual quantities as verified by the Owner.

**UNIT PRICES:** This form shall be used for any & all work required by the Bidding Documents & described as unit prices. Amounts shall be stated in figures & only in figures.

<b>Description:</b> <input checked="" type="checkbox"/> BASE BID OR <input type="checkbox"/> ALT # DIRECTIONAL DRILL 6" SEWER FORCE MAIN (HPDE DR-11)				
<b>REF NO.:</b>	<b>QUANTITY</b>	<b>UNIT OF MEASURE</b>	<b>UNIT PRICE</b>	<b>UNIT PRICE EXTENSION (Quantity times unit price)</b>
341	1	LF		
<b>Description:</b> <input checked="" type="checkbox"/> BASE BID OR <input type="checkbox"/> ALT # DIRECTIONAL DRILL 8" SEWER FORCE MAIN (HPDE DR-11)				
<b>REF NO.:</b>	<b>QUANTITY</b>	<b>UNIT OF MEASURE</b>	<b>UNIT PRICE</b>	<b>UNIT PRICE EXTENSION (Quantity times unit price)</b>
342	1	LF		
<b>Description:</b> <input checked="" type="checkbox"/> BASE BID OR <input type="checkbox"/> ALT # DIRECTIONAL DRILL 10" SEWER FORCE MAIN (HPDE DR-11)				
<b>REF NO.:</b>	<b>QUANTITY</b>	<b>UNIT OF MEASURE</b>	<b>UNIT PRICE</b>	<b>UNIT PRICE EXTENSION (Quantity times unit price)</b>
343	1	LF		
<b>Description:</b> <input checked="" type="checkbox"/> BASE BID OR <input type="checkbox"/> ALT # DIRECTIONAL DRILL 12" SEWER FORCE MAIN (HPDE DR-11)				
<b>REF NO.:</b>	<b>QUANTITY</b>	<b>UNIT OF MEASURE</b>	<b>UNIT PRICE</b>	<b>UNIT PRICE EXTENSION (Quantity times unit price)</b>
344	1	LF		
<b>Description:</b> <input checked="" type="checkbox"/> BASE BID OR <input type="checkbox"/> ALT # DIRECTIONAL DRILL 14" SEWER FORCE MAIN (HPDE DR-11)				
<b>REF NO.:</b>	<b>QUANTITY</b>	<b>UNIT OF MEASURE</b>	<b>UNIT PRICE</b>	<b>UNIT PRICE EXTENSION (Quantity times unit price)</b>
345	1	LF		
<b>Description:</b> <input checked="" type="checkbox"/> BASE BID OR <input type="checkbox"/> ALT # DIRECTIONAL DRILL 16" SEWER FORCE MAIN (HPDE DR-11)				
<b>REF NO.:</b>	<b>QUANTITY</b>	<b>UNIT OF MEASURE</b>	<b>UNIT PRICE</b>	<b>UNIT PRICE EXTENSION (Quantity times unit price)</b>
346	1	LF		

Version 2017.02

**Wording for "description" is to be provided by the Owner. All Quantities Estimated. The Contractor will be paid based upon actual quantities as verified by the Owner.**

**UNIT PRICES:** This form shall be used for any & all work required by the Bidding Documents & described as unit prices. Amounts shall be stated in figures & only in figures.

<b>Description:</b> <input checked="" type="checkbox"/> BASE BID OR <input type="checkbox"/> ALT # FURNISH & INSTALL SEWER VALVE - 2"				
<b>REF NO.:</b>	<b>QUANTITY</b>	<b>UNIT OF MEASURE</b>	<b>UNIT PRICE</b>	<b>UNIT PRICE EXTENSION (Quantity times unit price)</b>
347	1	EA		
<b>Description:</b> <input checked="" type="checkbox"/> BASE BID OR <input type="checkbox"/> ALT # FURNISH & INSTALL SEWER VALVE - 3"				
<b>REF NO.:</b>	<b>QUANTITY</b>	<b>UNIT OF MEASURE</b>	<b>UNIT PRICE</b>	<b>UNIT PRICE EXTENSION (Quantity times unit price)</b>
348	1	EA		
<b>Description:</b> <input checked="" type="checkbox"/> BASE BID OR <input type="checkbox"/> ALT # FURNISH & INSTALL SEWER VALVE - 4"				
<b>REF NO.:</b>	<b>QUANTITY</b>	<b>UNIT OF MEASURE</b>	<b>UNIT PRICE</b>	<b>UNIT PRICE EXTENSION (Quantity times unit price)</b>
349	1	EA		
<b>Description:</b> <input checked="" type="checkbox"/> BASE BID OR <input type="checkbox"/> ALT # FURNISH & INSTALL SEWER VALVE - 6"				
<b>REF NO.:</b>	<b>QUANTITY</b>	<b>UNIT OF MEASURE</b>	<b>UNIT PRICE</b>	<b>UNIT PRICE EXTENSION (Quantity times unit price)</b>
350	1	EA		
<b>Description:</b> <input checked="" type="checkbox"/> BASE BID OR <input type="checkbox"/> ALT # FURNISH & INSTALL SEWER VALVE - 8"				
<b>REF NO.:</b>	<b>QUANTITY</b>	<b>UNIT OF MEASURE</b>	<b>UNIT PRICE</b>	<b>UNIT PRICE EXTENSION (Quantity times unit price)</b>
351	1	EA		
<b>Description:</b> <input checked="" type="checkbox"/> BASE BID OR <input type="checkbox"/> ALT # FURNISH & INSTALL SEWER VALVE - 10"				
<b>REF NO.:</b>	<b>QUANTITY</b>	<b>UNIT OF MEASURE</b>	<b>UNIT PRICE</b>	<b>UNIT PRICE EXTENSION (Quantity times unit price)</b>
352	1	EA		

Version 2017-02  
Wording for "description" is to be provided by the Owner. All Quantities Estimated. The Contractor will be paid based upon actual quantities as verified by the Owner.



**UNIT PRICES:** This form shall be used for any & all work required by the Bidding Documents & described as unit prices. Amounts shall be stated in figures & only in figures.

<b>Description:</b> <input checked="" type="checkbox"/> BASE BID OR <input type="checkbox"/> ALT # FURNISH & INSTALL SEWER VALVE - 12"				
<b>REF NO.:</b>	<b>QUANTITY</b>	<b>UNIT OF MEASURE</b>	<b>UNIT PRICE</b>	<b>UNIT PRICE EXTENSION (Quantity times unit price)</b>
353	1	EA		
<b>Description:</b> <input checked="" type="checkbox"/> BASE BID OR <input type="checkbox"/> ALT # FURNISH & INSTALL SEWER VALVE - 14"				
<b>REF NO.:</b>	<b>QUANTITY</b>	<b>UNIT OF MEASURE</b>	<b>UNIT PRICE</b>	<b>UNIT PRICE EXTENSION (Quantity times unit price)</b>
354	1	EA		
<b>Description:</b> <input checked="" type="checkbox"/> BASE BID OR <input type="checkbox"/> ALT # FURNISH & INSTALL SEWER VALVE - 16"				
<b>REF NO.:</b>	<b>QUANTITY</b>	<b>UNIT OF MEASURE</b>	<b>UNIT PRICE</b>	<b>UNIT PRICE EXTENSION (Quantity times unit price)</b>
355	1	EA		
<b>Description:</b> <input checked="" type="checkbox"/> BASE BID OR <input type="checkbox"/> ALT # FURNISH & INSTALL SEWER VALVE BOX (ALL SIZES AND DEPTHS)				
<b>REF NO.:</b>	<b>QUANTITY</b>	<b>UNIT OF MEASURE</b>	<b>UNIT PRICE</b>	<b>UNIT PRICE EXTENSION (Quantity times unit price)</b>
356	1	EA		
<b>Description:</b> <input checked="" type="checkbox"/> BASE BID OR <input type="checkbox"/> ALT # RESETTING EXISTING MANHOLE RINGS & COVERS				
<b>REF NO.:</b>	<b>QUANTITY</b>	<b>UNIT OF MEASURE</b>	<b>UNIT PRICE</b>	<b>UNIT PRICE EXTENSION (Quantity times unit price)</b>
357	1	EA		
<b>Description:</b> <input checked="" type="checkbox"/> BASE BID OR <input type="checkbox"/> ALT # ADJUST SEWER MANHOLE				
<b>REF NO.:</b>	<b>QUANTITY</b>	<b>UNIT OF MEASURE</b>	<b>UNIT PRICE</b>	<b>UNIT PRICE EXTENSION (Quantity times unit price)</b>
358	1	EA		

Version 2017 Q2

Wording for "description" is to be provided by the Owner. All Quantities Estimated. The Contractor will be paid based upon actual quantities as verified by the Owner.

**UNIT PRICES:** This form shall be used for any & all work required by the Bidding Documents & described as unit prices. Amounts shall be stated in figures & only in figures.

<b>Description:</b> <input checked="" type="checkbox"/> BASE BID OR <input type="checkbox"/> ALT # REPAIR MANHOLE/ LINE CONNECTION				
<b>REF NO.:</b>	<b>QUANTITY</b>	<b>UNIT OF MEASURE</b>	<b>UNIT PRICE</b>	<b>UNIT PRICE EXTENSION (Quantity times unit price)</b>
359	1	EA		
<b>Description:</b> <input checked="" type="checkbox"/> BASE BID OR <input type="checkbox"/> ALT # REHABILITATE MANHOLE BENCH/ TROUGH				
<b>REF NO.:</b>	<b>QUANTITY</b>	<b>UNIT OF MEASURE</b>	<b>UNIT PRICE</b>	<b>UNIT PRICE EXTENSION (Quantity times unit price)</b>
360	1	EA		
<b>Description:</b> <input checked="" type="checkbox"/> BASE BID OR <input type="checkbox"/> ALT # SEWER MANHOLE/ WET WELL COATING				
<b>REF NO.:</b>	<b>QUANTITY</b>	<b>UNIT OF MEASURE</b>	<b>UNIT PRICE</b>	<b>UNIT PRICE EXTENSION (Quantity times unit price)</b>
361	1	SF		
<b>Description:</b> <input checked="" type="checkbox"/> BASE BID OR <input type="checkbox"/> ALT # REMOVE & REPLACE MANHOLE WALL				
<b>REF NO.:</b>	<b>QUANTITY</b>	<b>UNIT OF MEASURE</b>	<b>UNIT PRICE</b>	<b>UNIT PRICE EXTENSION (Quantity times unit price)</b>
362	1	VFT		
<b>Description:</b> <input checked="" type="checkbox"/> BASE BID OR <input type="checkbox"/> ALT # REMOVE & REPLACE MANHOLE CONE				
<b>REF NO.:</b>	<b>QUANTITY</b>	<b>UNIT OF MEASURE</b>	<b>UNIT PRICE</b>	<b>UNIT PRICE EXTENSION (Quantity times unit price)</b>
363	1	EA		
<b>Description:</b> <input checked="" type="checkbox"/> BASE BID OR <input type="checkbox"/> ALT # FURNISH & INSTALL NEW MANHOLE RINGS & COVERS				
<b>REF NO.:</b>	<b>QUANTITY</b>	<b>UNIT OF MEASURE</b>	<b>UNIT PRICE</b>	<b>UNIT PRICE EXTENSION (Quantity times unit price)</b>
364	1	EA		

Wording for "description" is to be provided by the Owner. All Quantities Estimated. The Contractor will be paid based upon actual quantities as verified by the Owner.

**UNIT PRICES:** This form shall be used for any & all work required by the Bidding Documents & described as unit prices. Amounts shall be stated in figures & only in figures.

<b>Description:</b> <input checked="" type="checkbox"/> BASE BID OR <input type="checkbox"/> ALT # FURNISH & INSTALL MANHOLE INSERTS				
<b>REF NO.:</b>	<b>QUANTITY</b>	<b>UNIT OF MEASURE</b>	<b>UNIT PRICE</b>	<b>UNIT PRICE EXTENSION (Quantity times unit price)</b>
365	1	EA		
<b>Description:</b> <input checked="" type="checkbox"/> BASE BID OR <input type="checkbox"/> ALT # FURNISH & INSTALL 48" CONCRETE SEWER MANHOLE - <10' DEEP				
<b>REF NO.:</b>	<b>QUANTITY</b>	<b>UNIT OF MEASURE</b>	<b>UNIT PRICE</b>	<b>UNIT PRICE EXTENSION (Quantity times unit price)</b>
366	1	EA		
<b>Description:</b> <input checked="" type="checkbox"/> BASE BID OR <input type="checkbox"/> ALT # FURNISH & INSTALL 48" CONCRETE SEWER MANHOLE - >10' DEEP				
<b>REF NO.:</b>	<b>QUANTITY</b>	<b>UNIT OF MEASURE</b>	<b>UNIT PRICE</b>	<b>UNIT PRICE EXTENSION (Quantity times unit price)</b>
367	1	EA		
<b>Description:</b> <input checked="" type="checkbox"/> BASE BID OR <input type="checkbox"/> ALT # FURNISH & INSTALL 60" CONCRETE SEWER MANHOLE - <10' DEEP				
<b>REF NO.:</b>	<b>QUANTITY</b>	<b>UNIT OF MEASURE</b>	<b>UNIT PRICE</b>	<b>UNIT PRICE EXTENSION (Quantity times unit price)</b>
368	1	EA		
<b>Description:</b> <input checked="" type="checkbox"/> BASE BID OR <input type="checkbox"/> ALT # FURNISH & INSTALL 60" CONCRETE SEWER MANHOLE - >10' DEEP				
<b>REF NO.:</b>	<b>QUANTITY</b>	<b>UNIT OF MEASURE</b>	<b>UNIT PRICE</b>	<b>UNIT PRICE EXTENSION (Quantity times unit price)</b>
369	1	EA		
<b>Description:</b> <input checked="" type="checkbox"/> BASE BID OR <input type="checkbox"/> ALT # INITIAL SET-UP BYPASS PUMP AND EQUIPMENT				
<b>REF NO.:</b>	<b>QUANTITY</b>	<b>UNIT OF MEASURE</b>	<b>UNIT PRICE</b>	<b>UNIT PRICE EXTENSION (Quantity times unit price)</b>
370	1	EA		

Wording for "description" is to be provided by the Owner. All Quantities Estimated. The Contractor will be paid based upon actual quantities as verified by the Owner.

**UNIT PRICES:** This form shall be used for any & all work required by the Bidding Documents & described as unit prices. Amounts shall be stated in figures & only in figures.

<b>Description:</b> <input checked="" type="checkbox"/> BASE BID OR <input type="checkbox"/> ALT # BYPASS PUMPING				
<b>REF NO.:</b>	<b>QUANTITY</b>	<b>UNIT OF MEASURE</b>	<b>UNIT PRICE</b>	<b>UNIT PRICE EXTENSION (Quantity times unit price)</b>
371	1	HR		
<b>Description:</b> <input checked="" type="checkbox"/> BASE BID OR <input type="checkbox"/> ALT # REPAIR/ ADJUST CLEANOUT				
<b>REF NO.:</b>	<b>QUANTITY</b>	<b>UNIT OF MEASURE</b>	<b>UNIT PRICE</b>	<b>UNIT PRICE EXTENSION (Quantity times unit price)</b>
372	1	EA		
<b>Description:</b> <input checked="" type="checkbox"/> BASE BID OR <input type="checkbox"/> ALT # FURNISH & INSTALL SEWER CLEANOUT				
<b>REF NO.:</b>	<b>QUANTITY</b>	<b>UNIT OF MEASURE</b>	<b>UNIT PRICE</b>	<b>UNIT PRICE EXTENSION (Quantity times unit price)</b>
373	1	EA		
<b>Description:</b> <input checked="" type="checkbox"/> BASE BID OR <input type="checkbox"/> ALT # 4" SEWER SERVICE LINE (PVC, SDR 26)				
<b>REF NO.:</b>	<b>QUANTITY</b>	<b>UNIT OF MEASURE</b>	<b>UNIT PRICE</b>	<b>UNIT PRICE EXTENSION (Quantity times unit price)</b>
374	1	LF		
<b>Description:</b> <input checked="" type="checkbox"/> BASE BID OR <input type="checkbox"/> ALT # 6" SEWER SERVICE LINE (PVC, SDR 26)				
<b>REF NO.:</b>	<b>QUANTITY</b>	<b>UNIT OF MEASURE</b>	<b>UNIT PRICE</b>	<b>UNIT PRICE EXTENSION (Quantity times unit price)</b>
375	1	LF		
<b>Description:</b> <input type="checkbox"/> BASE BID OR <input type="checkbox"/> ALT # SEWER SERVICE LINE WYE (6" X 4" X 4")				
<b>REF NO.:</b>	<b>QUANTITY</b>	<b>UNIT OF MEASURE</b>	<b>UNIT PRICE</b>	<b>UNIT PRICE EXTENSION (Quantity times unit price)</b>
376	1	EA		

Version 2017-02

Wording for "description" is to be provided by the Owner. All Quantities Estimated. The Contractor will be paid based upon actual quantities as verified by the Owner.

**UNIT PRICES:** This form shall be used for any & all work required by the Bidding Documents & described as unit prices. Amounts shall be stated in figures & only in figures.

<b>Description:</b> <input checked="" type="checkbox"/> BASE BID <input type="checkbox"/> Δ I T      SEWER WYE FOR 8" DIAMETER SEWER MAIN				
<b>REF NO.:</b>	<b>QUANTITY</b>	<b>UNIT OF MEASURE</b>	<b>UNIT PRICE</b>	<b>UNIT PRICE EXTENSION (Quantity times unit price)</b>
377	1	EA		
<b>Description:</b> <input checked="" type="checkbox"/> BASE BID <input type="checkbox"/> Δ I T      SEWER WYE FOR 10" DIAMETER SEWER MAIN				
<b>REF NO.:</b>	<b>QUANTITY</b>	<b>UNIT OF MEASURE</b>	<b>UNIT PRICE</b>	<b>UNIT PRICE EXTENSION (Quantity times unit price)</b>
378	1	EA		
<b>Description:</b> <input checked="" type="checkbox"/> BASE BID <input type="checkbox"/> Δ I T      SEWER WYE FOR 12" DIAMETER SEWER MAIN				
<b>REF NO.:</b>	<b>QUANTITY</b>	<b>UNIT OF MEASURE</b>	<b>UNIT PRICE</b>	<b>UNIT PRICE EXTENSION (Quantity times unit price)</b>
379	1	EA		

Wording for "description" is to be provided by the Owner. All Quantities Estimated. The Contractor will be paid based upon actual quantities as verified by the Owner.

**UNIT PRICES:** This form shall be used for any & all work required by the Bidding Documents & described as unit prices. Amounts shall be stated in figures & only in figures.

<b>Description:</b> <input checked="" type="checkbox"/> BASE BID <input type="checkbox"/> ALT WATER LINE POINT REPAIR – UP TO 2" (0'-6' DEPTH)				
<b>REF NO.:</b>	<b>QUANTITY</b>	<b>UNIT OF MEASURE</b>	<b>UNIT PRICE</b>	<b>UNIT PRICE EXTENSION (Quantity times unit price)</b>
401	1	EA		
<b>Description:</b> <input checked="" type="checkbox"/> BASE BID <input type="checkbox"/> ALT WATER LINE POINT REPAIR – UP TO 2" (6.1'-10' DEPTH)				
<b>REF NO.:</b>	<b>QUANTITY</b>	<b>UNIT OF MEASURE</b>	<b>UNIT PRICE</b>	<b>UNIT PRICE EXTENSION (Quantity times unit price)</b>
402	1	EA		
<b>Description:</b> <input checked="" type="checkbox"/> BASE BID <input type="checkbox"/> ALT WATER LINE POINT REPAIR – UP TO 2" (10.1'-12' DEPTH)				
<b>REF NO.:</b>	<b>QUANTITY</b>	<b>UNIT OF MEASURE</b>	<b>UNIT PRICE</b>	<b>UNIT PRICE EXTENSION (Quantity times unit price)</b>
403	1	EA		
<b>Description:</b> <input checked="" type="checkbox"/> BASE BID <input type="checkbox"/> ALT WATER LINE POINT REPAIR – UP TO 2" (>12' DEPTH)				
<b>REF NO.:</b>	<b>QUANTITY</b>	<b>UNIT OF MEASURE</b>	<b>UNIT PRICE</b>	<b>UNIT PRICE EXTENSION (Quantity times unit price)</b>
404	1	EA		
<b>Description:</b> <input checked="" type="checkbox"/> BASE BID <input type="checkbox"/> ALT WATER LINE POINT REPAIR – 3" (0'-6' DEPTH)				
<b>REF NO.:</b>	<b>QUANTITY</b>	<b>UNIT OF MEASURE</b>	<b>UNIT PRICE</b>	<b>UNIT PRICE EXTENSION (Quantity times unit price)</b>
405	1	EA		
<b>Description:</b> <input checked="" type="checkbox"/> BASE BID <input type="checkbox"/> ALT WATER LINE POINT REPAIR – 3" (6.1'-10' DEPTH)				
<b>REF NO.:</b>	<b>QUANTITY</b>	<b>UNIT OF MEASURE</b>	<b>UNIT PRICE</b>	<b>UNIT PRICE EXTENSION (Quantity times unit price)</b>
406	1	EA		

Version 2017-02

Wording for "description" is to be provided by the Owner. All Quantities Estimated. The Contractor will be paid based upon actual quantities as verified by the Owner.

**UNIT PRICES:** This form shall be used for any & all work required by the Bidding Documents & described as unit prices. Amounts shall be stated in figures & only in figures.

<b>Description:</b> <input checked="" type="checkbox"/> BASE BID <input type="checkbox"/> A I T WATER LINE POINT REPAIR – 3" (10.1'-12' DEPTH)				
<b>REF NO.:</b>	<b>QUANTITY</b>	<b>UNIT OF MEASURE</b>	<b>UNIT PRICE</b>	<b>UNIT PRICE EXTENSION (Quantity times unit price)</b>
407	1	EA		
<b>Description:</b> <input checked="" type="checkbox"/> BASE BID <input type="checkbox"/> A I T WATER LINE POINT REPAIR – 3" (>12' DEPTH)				
<b>REF NO.:</b>	<b>QUANTITY</b>	<b>UNIT OF MEASURE</b>	<b>UNIT PRICE</b>	<b>UNIT PRICE EXTENSION (Quantity times unit price)</b>
408	1	EA		
<b>Description:</b> <input checked="" type="checkbox"/> BASE BID <input type="checkbox"/> A I T WATER LINE POINT REPAIR – 4" (0'-6' DEPTH)				
<b>REF NO.:</b>	<b>QUANTITY</b>	<b>UNIT OF MEASURE</b>	<b>UNIT PRICE</b>	<b>UNIT PRICE EXTENSION (Quantity times unit price)</b>
409	1	EA		
<b>Description:</b> <input checked="" type="checkbox"/> BASE BID <input type="checkbox"/> A I T WATER LINE POINT REPAIR – 4" (6.1'-10' DEPTH)				
<b>REF NO.:</b>	<b>QUANTITY</b>	<b>UNIT OF MEASURE</b>	<b>UNIT PRICE</b>	<b>UNIT PRICE EXTENSION (Quantity times unit price)</b>
410	1	EA		
<b>Description:</b> <input checked="" type="checkbox"/> BASE BID <input type="checkbox"/> A I T WATER LINE POINT REPAIR – 4" (10.1'-12' DEPTH)				
<b>REF NO.:</b>	<b>QUANTITY</b>	<b>UNIT OF MEASURE</b>	<b>UNIT PRICE</b>	<b>UNIT PRICE EXTENSION (Quantity times unit price)</b>
411	1	EA		
<b>Description:</b> <input checked="" type="checkbox"/> BASE BID <input type="checkbox"/> A I T WATER LINE POINT REPAIR – 4" (>12' DEPTH)				
<b>REF NO.:</b>	<b>QUANTITY</b>	<b>UNIT OF MEASURE</b>	<b>UNIT PRICE</b>	<b>UNIT PRICE EXTENSION (Quantity times unit price)</b>
412	1	EA		

Version 2017-02  
Wording for "description" is to be provided by the Owner. All Quantities Estimated. The Contractor will be paid based upon actual quantities as verified by the Owner.

**UNIT PRICES:** This form shall be used for any & all work required by the Bidding Documents & described as unit prices. Amounts shall be stated in figures & only in figures.

<b>Description:</b> <input checked="" type="checkbox"/> BASE BID <input type="checkbox"/> A I T WATER MAIN POINT REPAIR – 6" (0'-6' DEPTH)				
<b>REF NO.:</b>	<b>QUANTITY</b>	<b>UNIT OF MEASURE</b>	<b>UNIT PRICE</b>	<b>UNIT PRICE EXTENSION (Quantity times unit price)</b>
413	1	EA		
<b>Description:</b> <input checked="" type="checkbox"/> BASE BID <input type="checkbox"/> A I T WATER MAIN POINT REPAIR – 6" (6.1'-10' DEPTH)				
<b>REF NO.:</b>	<b>QUANTITY</b>	<b>UNIT OF MEASURE</b>	<b>UNIT PRICE</b>	<b>UNIT PRICE EXTENSION (Quantity times unit price)</b>
414	1	EA		
<b>Description:</b> <input checked="" type="checkbox"/> BASE BID <input type="checkbox"/> A I T WATER MAIN POINT REPAIR – 6" (10.1'-12' DEPTH)				
<b>REF NO.:</b>	<b>QUANTITY</b>	<b>UNIT OF MEASURE</b>	<b>UNIT PRICE</b>	<b>UNIT PRICE EXTENSION (Quantity times unit price)</b>
415	1	EA		
<b>Description:</b> <input checked="" type="checkbox"/> BASE BID <input type="checkbox"/> A I T WATER MAIN POINT REPAIR – 6" (>12' DEPTH)				
<b>REF NO.:</b>	<b>QUANTITY</b>	<b>UNIT OF MEASURE</b>	<b>UNIT PRICE</b>	<b>UNIT PRICE EXTENSION (Quantity times unit price)</b>
416	1	EA		
<b>Description:</b> <input checked="" type="checkbox"/> BASE BID <input type="checkbox"/> A I T WATER MAIN POINT REPAIR – 8" (0'-6' DEPTH)				
<b>REF NO.:</b>	<b>QUANTITY</b>	<b>UNIT OF MEASURE</b>	<b>UNIT PRICE</b>	<b>UNIT PRICE EXTENSION (Quantity times unit price)</b>
417	1	EA		
<b>Description:</b> <input checked="" type="checkbox"/> BASE BID <input type="checkbox"/> A I T WATER MAIN POINT REPAIR – 8" (6.1'-10' DEPTH)				
<b>REF NO.:</b>	<b>QUANTITY</b>	<b>UNIT OF MEASURE</b>	<b>UNIT PRICE</b>	<b>UNIT PRICE EXTENSION (Quantity times unit price)</b>
418	1	EA		

Wording for "description" is to be provided by the Owner. All Quantities Estimated. The Contractor will be paid based upon actual quantities as verified by the Owner.



**UNIT PRICES:** This form shall be used for any & all work required by the Bidding Documents & described as unit prices. Amounts shall be stated in figures & only in figures.

<b>Description:</b> <input checked="" type="checkbox"/> BASE BID <input type="checkbox"/> A I T      WATER MAIN POINT REPAIR - 8" (10.1'-12' DEPTH)				
<b>REF NO.:</b>	<b>QUANTITY</b>	<b>UNIT OF MEASURE</b>	<b>UNIT PRICE</b>	<b>UNIT PRICE EXTENSION (Quantity times unit price)</b>
419	1	EA		
<b>Description:</b> <input checked="" type="checkbox"/> BASE BID <input type="checkbox"/> A I T      WATER MAIN POINT REPAIR - 8" (>12' DEPTH)				
<b>REF NO.:</b>	<b>QUANTITY</b>	<b>UNIT OF MEASURE</b>	<b>UNIT PRICE</b>	<b>UNIT PRICE EXTENSION (Quantity times unit price)</b>
420	1	EA		
<b>Description:</b> <input checked="" type="checkbox"/> BASE BID <input type="checkbox"/> A I T      WATER MAIN POINT REPAIR - 10" (0'-6' DEPTH)				
<b>REF NO.:</b>	<b>QUANTITY</b>	<b>UNIT OF MEASURE</b>	<b>UNIT PRICE</b>	<b>UNIT PRICE EXTENSION (Quantity times unit price)</b>
421	1	EA		
<b>Description:</b> <input checked="" type="checkbox"/> BASE BID <input type="checkbox"/> A I T      WATER MAIN POINT REPAIR - 10" (6.1'-10' DEPTH)				
<b>REF NO.:</b>	<b>QUANTITY</b>	<b>UNIT OF MEASURE</b>	<b>UNIT PRICE</b>	<b>UNIT PRICE EXTENSION (Quantity times unit price)</b>
422	1	EA		
<b>Description:</b> <input checked="" type="checkbox"/> BASE BID <input type="checkbox"/> A I T      WATER MAIN POINT REPAIR - 10" (10.1'-12' DEPTH)				
<b>REF NO.:</b>	<b>QUANTITY</b>	<b>UNIT OF MEASURE</b>	<b>UNIT PRICE</b>	<b>UNIT PRICE EXTENSION (Quantity times unit price)</b>
423	1	EA		
<b>Description:</b> <input checked="" type="checkbox"/> BASE BID <input type="checkbox"/> A I T      WATER MAIN POINT REPAIR - 10" (>12' DEPTH)				
<b>REF NO.:</b>	<b>QUANTITY</b>	<b>UNIT OF MEASURE</b>	<b>UNIT PRICE</b>	<b>UNIT PRICE EXTENSION (Quantity times unit price)</b>
424	1	EA		

Version 2017-02  
Wording for "description" is to be provided by the Owner. All Quantities Estimated. The Contractor will be paid based upon actual quantities as verified by the Owner.

**UNIT PRICES:** This form shall be used for any & all work required by the Bidding Documents & described as unit prices. Amounts shall be stated in figures & only in figures.

<b>Description:</b> <input checked="" type="checkbox"/> BASE BID <input type="checkbox"/> ALT WATER MAIN POINT REPAIR - 12" (0'-6' DEPTH)				
<b>REF NO.:</b>	<b>QUANTITY</b>	<b>UNIT OF MEASURE</b>	<b>UNIT PRICE</b>	<b>UNIT PRICE EXTENSION (Quantity times unit price)</b>
425	1	EA		
<b>Description:</b> <input checked="" type="checkbox"/> BASE BID <input type="checkbox"/> ALT WATER MAIN POINT REPAIR - 12" (6.1'-10' DEPTH)				
<b>REF NO.:</b>	<b>QUANTITY</b>	<b>UNIT OF MEASURE</b>	<b>UNIT PRICE</b>	<b>UNIT PRICE EXTENSION (Quantity times unit price)</b>
426	1	EA		
<b>Description:</b> <input checked="" type="checkbox"/> BASE BID <input type="checkbox"/> ALT WATER MAIN POINT REPAIR - 12" (10.1'-12' DEPTH)				
<b>REF NO.:</b>	<b>QUANTITY</b>	<b>UNIT OF MEASURE</b>	<b>UNIT PRICE</b>	<b>UNIT PRICE EXTENSION (Quantity times unit price)</b>
427	1	EA		
<b>Description:</b> <input checked="" type="checkbox"/> BASE BID <input type="checkbox"/> ALT WATER MAIN POINT REPAIR - 12" (>12' DEPTH)				
<b>REF NO.:</b>	<b>QUANTITY</b>	<b>UNIT OF MEASURE</b>	<b>UNIT PRICE</b>	<b>UNIT PRICE EXTENSION (Quantity times unit price)</b>
428	1	EA		
<b>Description:</b> <input checked="" type="checkbox"/> BASE BID <input type="checkbox"/> ALT WATER MAIN POINT REPAIR - 14" (0'-6' DEPTH)				
<b>REF NO.:</b>	<b>QUANTITY</b>	<b>UNIT OF MEASURE</b>	<b>UNIT PRICE</b>	<b>UNIT PRICE EXTENSION (Quantity times unit price)</b>
429	1	EA		
<b>Description:</b> <input checked="" type="checkbox"/> BASE BID <input type="checkbox"/> ALT WATER MAIN POINT REPAIR - 14" (6.1'-10' DEPTH)				
<b>REF NO.:</b>	<b>QUANTITY</b>	<b>UNIT OF MEASURE</b>	<b>UNIT PRICE</b>	<b>UNIT PRICE EXTENSION (Quantity times unit price)</b>
430	1	EA		

Version 2017-02

Wording for "description" is to be provided by the Owner. All Quantities Estimated. The Contractor will be paid based upon actual quantities as verified by the Owner.

**UNIT PRICES:** This form shall be used for any & all work required by the Bidding Documents & described as unit prices. Amounts shall be stated in figures & only in figures.

<b>Description:</b> <input checked="" type="checkbox"/> BASE BID <input type="checkbox"/> A I T      WATER MAIN POINT REPAIR – 14" (10.1'-12' DEPTH)				
<b>REF NO.:</b>	<b>QUANTITY</b>	<b>UNIT OF MEASURE</b>	<b>UNIT PRICE</b>	<b>UNIT PRICE EXTENSION (Quantity times unit price)</b>
431	1	EA		
<b>Description:</b> <input checked="" type="checkbox"/> BASE BID <input type="checkbox"/> A I T      WATER MAIN POINT REPAIR – 14" (>12' DEPTH)				
<b>REF NO.:</b>	<b>QUANTITY</b>	<b>UNIT OF MEASURE</b>	<b>UNIT PRICE</b>	<b>UNIT PRICE EXTENSION (Quantity times unit price)</b>
432	1	EA		
<b>Description:</b> <input checked="" type="checkbox"/> BASE BID <input type="checkbox"/> A I T      WATER MAIN POINT REPAIR – 16" (0'-6' DEPTH)				
<b>REF NO.:</b>	<b>QUANTITY</b>	<b>UNIT OF MEASURE</b>	<b>UNIT PRICE</b>	<b>UNIT PRICE EXTENSION (Quantity times unit price)</b>
433	1	EA		
<b>Description:</b> <input checked="" type="checkbox"/> BASE BID <input type="checkbox"/> A I T      WATER MAIN POINT REPAIR – 16" (6.1'-10' DEPTH)				
<b>REF NO.:</b>	<b>QUANTITY</b>	<b>UNIT OF MEASURE</b>	<b>UNIT PRICE</b>	<b>UNIT PRICE EXTENSION (Quantity times unit price)</b>
434	1	EA		
<b>Description:</b> <input checked="" type="checkbox"/> BASE BID <input type="checkbox"/> A I T      WATER MAIN POINT REPAIR – 16" (10.1'-12' DEPTH)				
<b>REF NO.:</b>	<b>QUANTITY</b>	<b>UNIT OF MEASURE</b>	<b>UNIT PRICE</b>	<b>UNIT PRICE EXTENSION (Quantity times unit price)</b>
435	1	EA		
<b>Description:</b> <input checked="" type="checkbox"/> BASE BID <input type="checkbox"/> A I T      WATER MAIN POINT REPAIR – 16" (>12' DEPTH)				
<b>REF NO.:</b>	<b>QUANTITY</b>	<b>UNIT OF MEASURE</b>	<b>UNIT PRICE</b>	<b>UNIT PRICE EXTENSION (Quantity times unit price)</b>
436	1	EA		

Version 2017-02  
**Wording for "description" is to be provided by the Owner. All Quantities Estimated. The Contractor will be paid based upon actual quantities as verified by the Owner.**

**UNIT PRICES:** This form shall be used for any & all work required by the Bidding Documents & described as unit prices. Amounts shall be stated in figures & only in figures.

<b>Description:</b> <input checked="" type="checkbox"/> BASE BID <input type="checkbox"/> A I T FURNISH & INSTALL 4" WATER LINE (PVC, C900 DR18)				
<b>REF NO.:</b>	<b>QUANTITY</b>	<b>UNIT OF MEASURE</b>	<b>UNIT PRICE</b>	<b>UNIT PRICE EXTENSION (Quantity times unit price)</b>
437	1	LF		
<b>Description:</b> <input checked="" type="checkbox"/> BASE BID <input type="checkbox"/> A I T FURNISH & INSTALL 6" WATER MAIN (PVC, C900 DR18)				
<b>REF NO.:</b>	<b>QUANTITY</b>	<b>UNIT OF MEASURE</b>	<b>UNIT PRICE</b>	<b>UNIT PRICE EXTENSION (Quantity times unit price)</b>
438	1	LF		
<b>Description:</b> <input checked="" type="checkbox"/> BASE BID <input type="checkbox"/> A I T FURNISH & INSTALL 8" WATER MAIN (PVC, C900 DR18)				
<b>REF NO.:</b>	<b>QUANTITY</b>	<b>UNIT OF MEASURE</b>	<b>UNIT PRICE</b>	<b>UNIT PRICE EXTENSION (Quantity times unit price)</b>
439	1	LF		
<b>Description:</b> <input checked="" type="checkbox"/> BASE BID <input type="checkbox"/> A I T FURNISH & INSTALL 10" WATER MAIN (PVC, C900 DR18)				
<b>REF NO.:</b>	<b>QUANTITY</b>	<b>UNIT OF MEASURE</b>	<b>UNIT PRICE</b>	<b>UNIT PRICE EXTENSION (Quantity times unit price)</b>
440	1	LF		
<b>Description:</b> <input checked="" type="checkbox"/> BASE BID <input type="checkbox"/> A I T FURNISH & INSTALL 12" WATER MAIN (PVC, C900 DR18)				
<b>REF NO.:</b>	<b>QUANTITY</b>	<b>UNIT OF MEASURE</b>	<b>UNIT PRICE</b>	<b>UNIT PRICE EXTENSION (Quantity times unit price)</b>
441	1	LF		
<b>Description:</b> <input checked="" type="checkbox"/> BASE BID <input type="checkbox"/> A I T FURNISH & INSTALL 14" WATER MAIN (PVC, C900 DR18)				
<b>REF NO.:</b>	<b>QUANTITY</b>	<b>UNIT OF MEASURE</b>	<b>UNIT PRICE</b>	<b>UNIT PRICE EXTENSION (Quantity times unit price)</b>
442	1	LF		

Wording for "description" is to be provided by the Owner. All Quantities Estimated. The Contractor will be paid based upon actual quantities as verified by the Owner.

**UNIT PRICES:** This form shall be used for any & all work required by the Bidding Documents & described as unit prices. Amounts shall be stated in figures & only in figures.

<b>Description:</b> <input checked="" type="checkbox"/> BASE BID <input type="checkbox"/> A I T FURNISH & INSTALL 16" WATER MAIN (PVC, C900 DR18)				
<b>REF NO.:</b>	<b>QUANTITY</b>	<b>UNIT OF MEASURE</b>	<b>UNIT PRICE</b>	<b>UNIT PRICE EXTENSION (Quantity times unit price)</b>
443	1	LF		
<b>Description:</b> <input checked="" type="checkbox"/> BASE BID <input type="checkbox"/> A I T DIRECTIONAL DRILL ¾" WATER SERVICE LINE (HPDE SDR9)				
<b>REF NO.:</b>	<b>QUANTITY</b>	<b>UNIT OF MEASURE</b>	<b>UNIT PRICE</b>	<b>UNIT PRICE EXTENSION (Quantity times unit price)</b>
444	1	LF		
<b>Description:</b> <input checked="" type="checkbox"/> BASE BID <input type="checkbox"/> A I T DIRECTIONAL DRILL 1" WATER LINE (HPDE SDR9)				
<b>REF NO.:</b>	<b>QUANTITY</b>	<b>UNIT OF MEASURE</b>	<b>UNIT PRICE</b>	<b>UNIT PRICE EXTENSION (Quantity times unit price)</b>
445	1	LF		
<b>Description:</b> <input checked="" type="checkbox"/> BASE BID <input type="checkbox"/> A I T DIRECTIONAL DRILL 2" WATER LINE (HPDE SDR9)				
<b>REF NO.:</b>	<b>QUANTITY</b>	<b>UNIT OF MEASURE</b>	<b>UNIT PRICE</b>	<b>UNIT PRICE EXTENSION (Quantity times unit price)</b>
446	1	LF		
<b>Description:</b> <input checked="" type="checkbox"/> BASE BID <input type="checkbox"/> A I T DIRECTIONAL DRILL 3" WATER LINE (HPDE DR-11)				
<b>REF NO.:</b>	<b>QUANTITY</b>	<b>UNIT OF MEASURE</b>	<b>UNIT PRICE</b>	<b>UNIT PRICE EXTENSION (Quantity times unit price)</b>
447	1	LF		
<b>Description:</b> <input checked="" type="checkbox"/> BASE BID <input type="checkbox"/> A I T DIRECTIONAL DRILL 4" WATER LINE (HPDE DR-11)				
<b>REF NO.:</b>	<b>QUANTITY</b>	<b>UNIT OF MEASURE</b>	<b>UNIT PRICE</b>	<b>UNIT PRICE EXTENSION (Quantity times unit price)</b>
448	1	LF		

Wording for "description" is to be provided by the Owner. All Quantities Estimated. The Contractor will be paid based upon actual quantities as verified by the Owner.

**UNIT PRICES:** This form shall be used for any & all work required by the Bidding Documents & described as unit prices. Amounts shall be stated in figures & only in figures.

<b>Description:</b> <input checked="" type="checkbox"/> BASE BID <input type="checkbox"/> A I T DIRECTIONAL DRILL 6" WATER MAIN (HPDE DR-11)				
<b>REF NO.:</b>	<b>QUANTITY</b>	<b>UNIT OF MEASURE</b>	<b>UNIT PRICE</b>	<b>UNIT PRICE EXTENSION (Quantity times unit price)</b>
449	1	LF		
<b>Description:</b> <input checked="" type="checkbox"/> BASE BID <input type="checkbox"/> A I T DIRECTIONAL DRILL 8" WATER MAIN (HPDE DR-11)				
<b>REF NO.:</b>	<b>QUANTITY</b>	<b>UNIT OF MEASURE</b>	<b>UNIT PRICE</b>	<b>UNIT PRICE EXTENSION (Quantity times unit price)</b>
450	1	LF		
<b>Description:</b> <input checked="" type="checkbox"/> BASE BID <input type="checkbox"/> A I T DIRECTIONAL DRILL 10" WATER MAIN (HPDE DR-11)				
<b>REF NO.:</b>	<b>QUANTITY</b>	<b>UNIT OF MEASURE</b>	<b>UNIT PRICE</b>	<b>UNIT PRICE EXTENSION (Quantity times unit price)</b>
451	1	LF		
<b>Description:</b> <input checked="" type="checkbox"/> BASE BID <input type="checkbox"/> A I T DIRECTIONAL DRILL 12" WATER MAIN (HPDE DR-11)				
<b>REF NO.:</b>	<b>QUANTITY</b>	<b>UNIT OF MEASURE</b>	<b>UNIT PRICE</b>	<b>UNIT PRICE EXTENSION (Quantity times unit price)</b>
452	1	LF		
<b>Description:</b> <input checked="" type="checkbox"/> BASE BID <input type="checkbox"/> A I T DIRECTIONAL DRILL 14" WATER MAIN (HPDE DR-11)				
<b>REF NO.:</b>	<b>QUANTITY</b>	<b>UNIT OF MEASURE</b>	<b>UNIT PRICE</b>	<b>UNIT PRICE EXTENSION (Quantity times unit price)</b>
453	1	LF		
<b>Description:</b> <input checked="" type="checkbox"/> BASE BID <input type="checkbox"/> A I T DIRECTIONAL DRILL 16" WATER MAIN (HPDE DR-11)				
<b>REF NO.:</b>	<b>QUANTITY</b>	<b>UNIT OF MEASURE</b>	<b>UNIT PRICE</b>	<b>UNIT PRICE EXTENSION (Quantity times unit price)</b>
454	1	LF		

Version 2017 Q2

Wording for "description" is to be provided by the Owner. All Quantities Estimated. The Contractor will be paid based upon actual quantities as verified by the Owner.

**UNIT PRICES:** This form shall be used for any & all work required by the Bidding Documents & described as unit prices. Amounts shall be stated in figures & only in figures.

<b>Description:</b> <input checked="" type="checkbox"/> BASE BID <input type="checkbox"/> ALT FURNISH & INSTALL WATER VALVE - 3/4" TO 1"				
<b>REF NO.:</b>	<b>QUANTITY</b>	<b>UNIT OF MEASURE</b>	<b>UNIT PRICE</b>	<b>UNIT PRICE EXTENSION (Quantity times unit price)</b>
455	1	EA		
<b>Description:</b> <input checked="" type="checkbox"/> BASE BID <input type="checkbox"/> ALT FURNISH & INSTALL WATER VALVE - 2"				
<b>REF NO.:</b>	<b>QUANTITY</b>	<b>UNIT OF MEASURE</b>	<b>UNIT PRICE</b>	<b>UNIT PRICE EXTENSION (Quantity times unit price)</b>
456	1	EA		
<b>Description:</b> <input checked="" type="checkbox"/> BASE BID <input type="checkbox"/> ALT FURNISH & INSTALL WATER VALVE - 3"				
<b>REF NO.:</b>	<b>QUANTITY</b>	<b>UNIT OF MEASURE</b>	<b>UNIT PRICE</b>	<b>UNIT PRICE EXTENSION (Quantity times unit price)</b>
457	1	EA		
<b>Description:</b> <input checked="" type="checkbox"/> BASE BID <input type="checkbox"/> ALT FURNISH & INSTALL WATER VALVE - 4"				
<b>REF NO.:</b>	<b>QUANTITY</b>	<b>UNIT OF MEASURE</b>	<b>UNIT PRICE</b>	<b>UNIT PRICE EXTENSION (Quantity times unit price)</b>
458	1	EA		
<b>Description:</b> <input checked="" type="checkbox"/> BASE BID <input type="checkbox"/> ALT FURNISH & INSTALL WATER VALVE - 8"				
<b>REF NO.:</b>	<b>QUANTITY</b>	<b>UNIT OF MEASURE</b>	<b>UNIT PRICE</b>	<b>UNIT PRICE EXTENSION (Quantity times unit price)</b>
459	1	EA		
<b>Description:</b> <input checked="" type="checkbox"/> BASE BID <input type="checkbox"/> ALT FURNISH & INSTALL WATER VALVE - 10"				
<b>REF NO.:</b>	<b>QUANTITY</b>	<b>UNIT OF MEASURE</b>	<b>UNIT PRICE</b>	<b>UNIT PRICE EXTENSION (Quantity times unit price)</b>
460	1	EA		

Version 2017 Q2

Wording for "description" is to be provided by the Owner. All Quantities Estimated. The Contractor will be paid based upon actual quantities as verified by the Owner.

**UNIT PRICES:** This form shall be used for any & all work required by the Bidding Documents & described as unit prices. Amounts shall be stated in figures & only in figures.

<b>Description:</b> <input checked="" type="checkbox"/> BASE BID <input type="checkbox"/> A I T      FURNISH & INSTALL WATER VALVE - 12"				
<b>REF NO.:</b>	<b>QUANTITY</b>	<b>UNIT OF MEASURE</b>	<b>UNIT PRICE</b>	<b>UNIT PRICE EXTENSION (Quantity times unit price)</b>
462	1	EA		
<b>Description:</b> <input checked="" type="checkbox"/> BASE BID <input type="checkbox"/> A I T      FURNISH & INSTALL WATER VALVE - 14"				
<b>REF NO.:</b>	<b>QUANTITY</b>	<b>UNIT OF MEASURE</b>	<b>UNIT PRICE</b>	<b>UNIT PRICE EXTENSION (Quantity times unit price)</b>
463	1	EA		
<b>Description:</b> <input checked="" type="checkbox"/> BASE BID <input type="checkbox"/> A I T      FURNISH & INSTALL WATER VALVE - 16"				
<b>REF NO.:</b>	<b>QUANTITY</b>	<b>UNIT OF MEASURE</b>	<b>UNIT PRICE</b>	<b>UNIT PRICE EXTENSION (Quantity times unit price)</b>
464	1	EA		
<b>Description:</b> <input checked="" type="checkbox"/> BASE BID <input type="checkbox"/> A I T      FURNISH & INSTALL WATER VALVE BOX (ALL SIZES AND DEPTHS)				
<b>REF NO.:</b>	<b>QUANTITY</b>	<b>UNIT OF MEASURE</b>	<b>UNIT PRICE</b>	<b>UNIT PRICE EXTENSION (Quantity times unit price)</b>
465	1	EA		
<b>Description:</b> <input checked="" type="checkbox"/> BASE BID <input type="checkbox"/> A I T      FURNISH & INSTALL WATER SERVICES - 3/4"				
<b>REF NO.:</b>	<b>QUANTITY</b>	<b>UNIT OF MEASURE</b>	<b>UNIT PRICE</b>	<b>UNIT PRICE EXTENSION (Quantity times unit price)</b>
466	1	LF		
<b>Description:</b> <input checked="" type="checkbox"/> BASE BID <input type="checkbox"/> A I T      FURNISH & INSTALL WATER SERVICES - 1"				
<b>REF NO.:</b>	<b>QUANTITY</b>	<b>UNIT OF MEASURE</b>	<b>UNIT PRICE</b>	<b>UNIT PRICE EXTENSION (Quantity times unit price)</b>
467	1	LF		

Wording for "description" is to be provided by the Owner. All Quantities Estimated. The Contractor will be paid based upon actual quantities as verified by the Owner.



**UNIT PRICES:** This form shall be used for any & all work required by the Bidding Documents & described as unit prices. Amounts shall be stated in figures & only in figures.

<b>Description:</b> <input checked="" type="checkbox"/> BASE BID <input type="checkbox"/> ALT FURNISH & INSTALL WATER SERVICES - 2"				
<b>REF NO.:</b>	<b>QUANTITY</b>	<b>UNIT OF MEASURE</b>	<b>UNIT PRICE</b>	<b>UNIT PRICE EXTENSION (Quantity times unit price)</b>
468	1	LF		
<b>Description:</b> <input checked="" type="checkbox"/> BASE BID <input type="checkbox"/> ALT FURNISH & INSTALL WATER SERVICES - 3"				
<b>REF NO.:</b>	<b>QUANTITY</b>	<b>UNIT OF MEASURE</b>	<b>UNIT PRICE</b>	<b>UNIT PRICE EXTENSION (Quantity times unit price)</b>
469	1	LF		
<b>Description:</b> <input checked="" type="checkbox"/> BASE BID <input type="checkbox"/> ALT FURNISH & INSTALL WATER SERVICES - 4"				
<b>REF NO.:</b>	<b>QUANTITY</b>	<b>UNIT OF MEASURE</b>	<b>UNIT PRICE</b>	<b>UNIT PRICE EXTENSION (Quantity times unit price)</b>
470	1	LF		
<b>Description:</b> <input checked="" type="checkbox"/> BASE BID <input type="checkbox"/> ALT FURNISH & INSTALL WATER SERVICES - 6"				
<b>REF NO.:</b>	<b>QUANTITY</b>	<b>UNIT OF MEASURE</b>	<b>UNIT PRICE</b>	<b>UNIT PRICE EXTENSION (Quantity times unit price)</b>
471	1	LF		
<b>Description:</b> <input checked="" type="checkbox"/> BASE BID <input type="checkbox"/> ALT FURNISH & INSTALL WATER SERVICES - 8"				
<b>REF NO.:</b>	<b>QUANTITY</b>	<b>UNIT OF MEASURE</b>	<b>UNIT PRICE</b>	<b>UNIT PRICE EXTENSION (Quantity times unit price)</b>
472	1	LF		
<b>Description:</b> <input checked="" type="checkbox"/> BASE BID <input type="checkbox"/> ALT FURNISH & INSTALL FIRE HYDRANT - 5 1/4", 3 - WAY				
<b>REF NO.:</b>	<b>QUANTITY</b>	<b>UNIT OF MEASURE</b>	<b>UNIT PRICE</b>	<b>UNIT PRICE EXTENSION (Quantity times unit price)</b>
473	1	EA		

Version 2017-02

Wording for "description" is to be provided by the Owner. All Quantities Estimated. The Contractor will be paid based upon actual quantities as verified by the Owner.

**UNIT PRICES:** This form shall be used for any & all work required by the Bidding Documents & described as unit prices. Amounts shall be stated in figures & only in figures.

<b>Description:</b> <input checked="" type="checkbox"/> BASE BID <input type="checkbox"/> A I T RAISE EXISTING FIRE HYDRANT - 6" EXTENSION				
<b>REF NO.:</b>	<b>QUANTITY</b>	<b>UNIT OF MEASURE</b>	<b>UNIT PRICE</b>	<b>UNIT PRICE EXTENSION (Quantity times unit price)</b>
474	1	EA		
<b>Description:</b> <input checked="" type="checkbox"/> BASE BID <input type="checkbox"/> A I T RAISE EXISTING FIRE HYDRANT - 12" EXTENSION				
<b>REF NO.:</b>	<b>QUANTITY</b>	<b>UNIT OF MEASURE</b>	<b>UNIT PRICE</b>	<b>UNIT PRICE EXTENSION (Quantity times unit price)</b>
475	1	EA		
<b>Description:</b> <input checked="" type="checkbox"/> BASE BID <input type="checkbox"/> A I T RAISE EXISTING FIRE HYDRANT - 18" EXTENSION				
<b>REF NO.:</b>	<b>QUANTITY</b>	<b>UNIT OF MEASURE</b>	<b>UNIT PRICE</b>	<b>UNIT PRICE EXTENSION (Quantity times unit price)</b>
476	1	EA		
<b>Description:</b> <input checked="" type="checkbox"/> BASE BID <input type="checkbox"/> A I T RAISE EXISTING FIRE HYDRANT - 24" EXTENSION				
<b>REF NO.:</b>	<b>QUANTITY</b>	<b>UNIT OF MEASURE</b>	<b>UNIT PRICE</b>	<b>UNIT PRICE EXTENSION (Quantity times unit price)</b>
477	1	EA		
<b>Description:</b> <input checked="" type="checkbox"/> BASE BID <input type="checkbox"/> A I T RAISE EXISTING FIRE HYDRANT - 30" EXTENSION				
<b>REF NO.:</b>	<b>QUANTITY</b>	<b>UNIT OF MEASURE</b>	<b>UNIT PRICE</b>	<b>UNIT PRICE EXTENSION (Quantity times unit price)</b>
478	1	EA		
<b>Description:</b> <input checked="" type="checkbox"/> BASE BID <input type="checkbox"/> A I T RAISE EXISTING FIRE HYDRANT - 36" EXTENSION				
<b>REF NO.:</b>	<b>QUANTITY</b>	<b>UNIT OF MEASURE</b>	<b>UNIT PRICE</b>	<b>UNIT PRICE EXTENSION (Quantity times unit price)</b>
479	1	EA		

Version 2017-02  
Wording for "description" is to be provided by the Owner. All Quantities Estimated. The Contractor will be paid based upon actual quantities as verified by the Owner.

**UNIT PRICES:** This form shall be used for any & all work required by the Bidding Documents & described as unit prices. Amounts shall be stated in figures & only in figures.

<b>Description:</b> <input checked="" type="checkbox"/> BASE BID <input type="checkbox"/> A I T      RAISE EXISTING FIRE HYDRANT - 42" EXTENSION				
<b>REF NO.:</b>	<b>QUANTITY</b>	<b>UNIT OF MEASURE</b>	<b>UNIT PRICE</b>	<b>UNIT PRICE EXTENSION (Quantity times unit price)</b>
480	1	EA		
<b>Description:</b> <input checked="" type="checkbox"/> BASE BID <input type="checkbox"/> A I T      RAISE EXISTING FIRE HYDRANT - 48" EXTENSION				
<b>REF NO.:</b>	<b>QUANTITY</b>	<b>UNIT OF MEASURE</b>	<b>UNIT PRICE</b>	<b>UNIT PRICE EXTENSION (Quantity times unit price)</b>
481	1	EA		

Wording for "description" is to be provided by the Owner. All Quantities Estimated. The Contractor will be paid based upon actual quantities as verified by the Owner.

Section 05

**AFFIDAVIT PURSUANT TO LSA-R.S. 38:2224 and 38:2227  
FOR BIDDERS FOR PUBLIC WORKS CONTRACTS**

STATE OF \_\_\_\_\_

PARISH/COUNTY OF \_\_\_\_\_

BEFORE ME, the undersigned authority, in and for the above stated State and Parish (or County), personally came and appeared:

\_\_\_\_\_  
Print Name

who, after first being duly sworn, did depose and state:

1. That affiant is appearing on behalf of \_\_\_\_\_, who is seeking a public contract with St. Tammany Parish Government.
2. That affiant employed no person, corporation, firm, association, or other organization, either directly or indirectly, to secure the public contract under which he received payment, other than persons regularly employed by the affiant whose services in connection with the construction, alteration or demolition of the public building or project or in securing the public contract were in the regular course of their duties for affiant; and
3. That no part of the contract price received by affiant was paid or will be paid to any person, corporation, firm, association, or other organization for soliciting the contract, other than the payment of their normal compensation to persons regularly employed by the affiant whose services in connection with the construction, alteration or demolition of the public building or project were in the regular course of their duties for affiant.
4. If affiant is a sole proprietor, that after July 2, 2010, he/she has not been convicted of, or has not entered a plea of guilty or *nolo contendere* to any of the crimes or equivalent federal crimes listed in LSA-R.S. 38:2227(B).
5. If affiant is executing this affidavit on behalf of a juridical entity such as a partnership, corporation, or LLC, etc., that no individual partner, incorporator, director, manager, officer, organizer, or member, who has a minimum of a ten percent ownership in the bidding entity, has been convicted of, or has entered a plea of guilty or *nolo contendere* to any

of the crimes or equivalent federal crimes listed in LSA-R.S. 38:2227(B).

6. If affiant is a sole proprietor, that neither affiant, nor his/her immediate family is a public servant of St. Tammany Parish Government or the Contract is not under the supervision or jurisdiction of the public servant's agency.
  
7. If affiant is executing this affidavit on behalf of a juridical entity such as a partnership, corporation, or LLC, etc., that no public servant of St. Tammany Parish Government, or his/her immediate family, either individually or collectively, has more than a 25% ownership interest in the entity seeking the Contract with St. Tammany Parish Government if the Contract will be under the supervision or jurisdiction of the public servant's agency.

\_\_\_\_\_  
**Printed Name:** \_\_\_\_\_  
**Title:** \_\_\_\_\_  
**Entity name:** \_\_\_\_\_

**THUS SWORN TO AND SUBSCRIBED BEFORE ME,**  
**THIS** \_\_\_\_\_, **DAY OF** \_\_\_\_\_, **202**\_\_.

\_\_\_\_\_  
**Notary Public**  
**Print Name:** \_\_\_\_\_  
**Notary I.D./Bar No.:** \_\_\_\_\_  
**My commission expires:** \_\_\_\_\_

**AFFIDAVIT PURSUANT TO LSA-R.S. 38:2212.10 CONFIRMING  
REGISTRATION AND PARTICIPATION IN A STATUS VERIFICATION  
SYSTEM**

STATE OF \_\_\_\_\_

PARISH/COUNTY OF \_\_\_\_\_

**BEFORE ME**, the undersigned authority, in and for the above stated State and Parish (or County), personally came and appeared:

\_\_\_\_\_

Print Name

who, after first being duly sworn, did depose and state:

1. That affiant is appearing on behalf of \_\_\_\_\_, a private employer seeking a bid or a contract with St. Tammany Parish Government for the physical performance of services within the State of Louisiana.
  
2. That affiant is registered and participates in a status verification system to verify that all employees in the state of Louisiana are legal citizens of the United States or are legal aliens; and
  
3. That affiant shall continue, during the term of the contract, to utilize a status verification system to verify the legal status of all new employees in the state of Louisiana.
  
4. That affiant shall require all subcontractors to submit to the affiant a sworn affidavit verifying compliance with this law.

\_\_\_\_\_  
**Printed Name:** \_\_\_\_\_

**Title:** \_\_\_\_\_

**Name of Entity:** \_\_\_\_\_

**THUS SWORN TO AND SUBSCRIBED BEFORE ME,  
THIS \_\_\_\_\_, DAY OF \_\_\_\_\_, 202\_\_.**

\_\_\_\_\_  
**Notary Public**

**Print Name:** \_\_\_\_\_

**Notary I.D./Bar No.:** \_\_\_\_\_

**My commission expires:** \_\_\_\_\_



## INSURANCE REQUIREMENTS\*

Construction Project: Utility Repair and Maintenance\_\_\_\_\_

Bid#: 23-20-2

### **\*\*\*IMPORTANT – PLEASE READ\*\*\***

**Prior to submitting your quote or bid, it is recommended that you review these insurance requirements with your insurance broker/agent.**

*These requirements modify portions of the insurance language found in the General Conditions and/or Supplementary General Conditions; however, there is no intention to remove all sections pertaining to insurance requirements and limits set forth in the General Conditions and/or Supplementary General Conditions, only to amend and specify those items particular for this Project.*

- A. The Provider shall secure and maintain at its expense such insurance that will protect it and St. Tammany Parish Government (the "Parish") from claims for bodily injury, death or property damage as well as from claims under the Workers' Compensation Acts that may arise from the performance of services under this agreement. All certificates of insurance shall be furnished to the Parish and provide thirty (30) days prior notice of cancellation to the Parish, in writing, on all of the required coverage.
- B. All policies shall provide for and certificates of insurance shall indicate the following:
1. Waiver of Subrogation: The Provider's insurers will have no right of recovery or subrogation against the Parish of St. Tammany, it being the intention of the parties that all insurance policy(ies) so affected shall protect both parties and be the primary coverage for any and all losses covered by the below described insurance.
  2. Additional Insured: St. Tammany Parish Government shall be named as Additional Insured with respect to general liability, automobile liability and excess liability coverages, as well as marine liability and pollution/environmental liability, when those coverages are required or necessary.
  3. Payment of Premiums: The insurance companies issuing the policy or policies will have no recourse against St. Tammany Parish Government for payment of any premiums or for assessments under any form of policy.
  4. Project Reference: The project(s) and location(s) shall be referenced in the Comment or Description of Operations section of the Certificate of Insurance (Project #-###, or Bid # if applicable, Type of Work, Location).
- C. Coverage must be issued by insurance companies authorized to do business in the State of Louisiana. Companies must have an A.M. Best rating of no less than A-, Category VII. St. Tammany Parish Risk Management Department may waive this requirement only for Workers Compensation coverage at their discretion.

Provider shall secure and present proof of insurance on forms acceptable to St. Tammany Parish Government, Office of Risk Management no later than the time of submission of the Contract to the Parish. However, should any work performed under this Contract by or on behalf of Provider include exposures that are not covered by those insurance coverages, Provider is not relieved of its obligation to maintain appropriate levels and types of insurance necessary to protect itself, its agents and employees, its subcontractors, St. Tammany Parish Government (Owner), and all other interested third parties, from any and all claims for damage or injury in connection with the services performed or provided throughout the duration of this Project, as well as for any subsequent periods required under this Contract.

The insurance coverages checked (✓) below are those required for this Contract.

- 1. **Commercial General Liability\*** insurance – **Occurrence Form** - with a Combined Single Limit for bodily injury and property damage of at least \$1,000,000 per Occurrence / \$2,000,000 General Aggregate and \$2,000,000 Products-Completed Operations. Contracts over \$1,000,000 may require higher limits. The insurance shall provide for and the certificate(s) of insurance shall indicate the following coverages:
  - a) Premises - operations;
  - b) Broad form contractual liability;
  - c) Products and completed operations;
  - d) Personal/Advertising Injury;
  - e) Broad form property damage (for Projects involving work on Parish property);
  - f) Explosion, Collapse and Damage to underground property.
  - g) Additional Insured forms CG 2010 and CG 2037 in most current edition are required.
  
- 2. **Business Automobile Liability\*** insurance with a Combined Single Limit of \$1,000,000 per Occurrence for bodily injury and property damage, and shall include coverage for the following:
  - a) Any auto;
  - or**
  - b) Owned autos; **and**
  - c) Hired autos; **and**
  - d) Non-owned autos.
  
- 3. **Workers' Compensation/Employers Liability insurance\*** - Workers' Compensation coverage as required by State law. Employers' liability limits shall be a minimum of \$1,000,000 each accident, \$1,000,000 each disease, \$1,000,000 disease policy aggregate. When water activities are expected to be performed in connection with this project, coverage under the USL&H Act, Jones Act and/or Maritime Employers Liability (MEL) must be included. **Coverage for owners, officers and/or partners in any way engaged in the Project shall be included in the policy.** The names of any excluded individual must be shown in the Description of Operations/Comments section of the Certificate.
  
- 4. **Pollution Liability and Environmental Liability\*** insurance in the minimum amount of \$1,000,000 per occurrence / \$2,000,000 aggregate including full contractual liability and third party claims for bodily injury and/or property damage, for all such hazardous waste, pollutants and/or environmental exposures that may be affected by this project stemming from pollution/environmental incidents as a result of Contractor's operations.

If coverage is provided on a claims-made basis, the following conditions apply:

- 1) the retroactive date must be prior to or coinciding with the effective date of the Contract, or prior to the commencement of any services provided by the Contractor on behalf of the Parish, whichever is earlier; AND
- 2) continuous coverage must be provided to the Parish with the same retro date for 24 months following acceptance or termination of the Project by the Parish either by
  - a) continued renewal certificates **OR**
  - b) a 24 month Extended Reporting Period

\*The Certificate must indicate whether the policy is written on an occurrence or claims-made basis and, if claims-made, the applicable retro date must be stated.



5. **Contractor's Professional Liability/Errors and Omissions\*** insurance in the sum of at least \$1,000,000 per claim / \$2,000,000 aggregate is required when work performed by Contractor or on behalf of Contractor includes professional or technical services including, but not limited to, construction administration and/or management, engineering services such as design, surveying, and/or inspection, technical services such as testing and laboratory analysis, and/or environmental assessments. An occurrence basis policy is preferred.

If coverage is provided on a claims-made basis, the following conditions apply:

- 1) the retroactive date must be prior to or coinciding with the effective date of the Contract, or prior to the commencement of any services provided by the Contractor on behalf of the Parish, whichever is earlier; AND
- 2) continuous coverage must be provided to the Parish with the same retro date for 24 months following acceptance or termination of the Project by the Parish either by
  - a) continued renewal certificates **OR**
  - b) a 24 month Extended Reporting Period

\*The Certificate must indicate whether the policy is written on an occurrence or claims-made basis and, if claims-made, the applicable retro date must be stated.

6. **Marine Liability/Protection and Indemnity\*** insurance is required for any and all vessel and/or marine operations in the minimum limits of \$1,000,000 per occurrence / \$2,000,000 per project general aggregate. The coverage shall include, but is not limited to, the basic coverages found in the Commercial General Liability insurance and coverage for third party liability

**\*Excess/Umbrella Liability** insurance may be provided to meet the limit requirements for any Liability coverage. For example: if the General Liability requirement is \$3,000,000 per occurrence, but the policy is only \$1,000,000 per occurrence, then the excess policy should be at least \$2,000,000 per occurrence thereby providing a combined per occurrence limit of \$3,000,000.)

7. **Owners Protective Liability (OPL)** shall be furnished by the Contractor and shall provide coverage in the minimum amount of \$1,000,000 CSL each occurrence / \$1,000,000 aggregate. **St. Tammany Parish Government, ATTN: Risk Management Department, P. O. Box 628, Covington, LA 70434 shall be the first named insured on the policy.**

8. **Builder's Risk Insurance** written on an "all-risk" policy form shall be furnished by Contractor for 100% of the contract cost. Any contract modifications increasing the contract cost will require an increase in the limit of the Builder's Risk policy. Deductibles should not exceed \$5,000 and Contractor shall be responsible for all policy deductibles. This insurance shall cover materials at the site, stored off the site, and in transit. The Builder's Risk Insurance shall include the interests of the Owner, Contractor and Subcontractors and shall terminate only when the Project is accepted in writing. **St. Tammany Parish Government, ATTN: Risk Management Department, P. O. Box 628, Covington, LA 70434 shall be the first named insured on the policy.**

9. **Installation Floater Insurance**, on an "all-risk" form, shall be furnished by Contractor and carried for the full value of the materials, machinery, equipment and labor for each location. The Contractor shall be responsible for all policy deductibles. The Installation Floater Insurance shall provide coverage for property owned by others and include the interests of the Owner, Contractor and Subcontractors and shall terminate only when the Project is accepted in writing. **St. Tammany Parish Government, ATTN: Risk Management Department, P. O. Box 628, Covington, LA 70434 shall be the first named insured on the policy.**

- D. All policies of insurance shall meet the requirements of the Parish prior to the commencing of any work. The Parish has the right, but not the duty, to approve all insurance coverages prior to commencement of work. If any of the required policies are or become unsatisfactory to the Parish as to form or substance; or if a company issuing any policy is or becomes unsatisfactory to the Parish, the Provider shall promptly obtain a new policy, timely submit same to the Parish for approval, and submit a certificate thereof as provided above. The Parish agrees not to unreasonably withhold approval of any insurance carrier selected by Provider. In the event that Parish cannot agree or otherwise authorize a carrier, Provider shall have the option of selecting and submitting a new insurance carrier within 30 days of said notice by the Parish. In the event that the second submission is insufficient or is not approved, then the Parish shall have the unilateral opportunity to thereafter select a responsive and responsible insurance carrier all at the cost of Provider and thereafter deduct from Provider's fee the cost of such insurance.
- E. Upon failure of Provider to furnish, deliver and/or maintain such insurance as above provided, this contract, at the election of the Parish, may be declared suspended, discontinued or terminated. Failure of the Provider to maintain insurance shall not relieve the Provider from any liability under the contract, nor shall the insurance requirements be construed to conflict with the obligation of the Provider concerning indemnification.
- F. Provider shall maintain a current copy of all annual insurance policies and agrees to provide a certificate of insurance to the Parish on an annual basis or as may be reasonably requested for the term of the contract or any required Extended Reporting Period. Provider further shall ensure that all insurance policies are maintained in full force and effect throughout the duration of the Project and shall provide the Parish with annual renewal certificates of insurance evidencing continued coverage, without any prompting by the Parish.
- G. It shall be the responsibility of Provider to require that these insurance requirements are met by all contractors and sub-contractors performing work for and on behalf of Provider. Provider shall further ensure the Parish is named as an additional insured on all insurance policies provided by said contractor and/or sub-contractor throughout the duration of the project.
- H. Certificates of Insurance shall be issued as follows:

**St. Tammany Parish Government  
Attn: Risk Management  
P O Box 628  
Covington, LA 70434**

To avoid contract processing delays, be certain the project name/number is included on all correspondence including Certificates of Insurance.

**\*NOTICE: St. Tammany Parish Government reserves the rights to remove, replace, make additions to and/or modify any and all of the insurance requirements at any time.**

**Any inquiry regarding these insurance requirements should be addressed to:**

**St. Tammany Parish Government  
Office of Risk Management  
P O Box 628  
Covington, LA 70434  
Telephone: 985-898-5226  
Email: riskman@stpgov.org**

**Section 07**

**Project Signs**

**OMITTED**

Section 08

**General Conditions for St. Tammany Parish Government**

**This index is for illustrative purposes only and is not intended to be complete nor exhaustive.**

**All bidders/contractors are presumed to have read and understood the entire document. Some information contained in these conditions may not be applicable to all projects.**

## GENERAL CONDITIONS INDEX

A.A.S.H.T.O	01.01
A.C.I.	01.02
ADDENDA	01.03, 01.05, 01.12, 02.13, 02.13, 06.02, 06.03
ADVERTISEMENT	01.04, 01.12, 02.21, 02.22, 02.23
AGREEMENT	01.05, 01.11, 01.12, 01.14, 01.15, 01.19, 03.02, 03.03, 03.04, 06.01, 06.02, 10.01, 11.03, 12.01, 14.02, 29.06, 32.01, 32.02, 33.06, 33.07
APPLICATION FOR PAYMENT	01.06, 29.07
A.S.T.M.	01.07
AWARD	03.00, 03.01, 03.04, 03.05
BID	01.08, 01.12, 01.26, 02.02, 02.04, 02.08, 02.09, 02.10, 02.13, 02.14, 02.17, 02.19, 02.21, 03.01, 03.04, 04.02, 14.03, 22.01, 23.01, 28.08
BIDDER	01.04, 01.08, 01.09, 01.26, 01.28, 02.02, 02.04, 02.06, 02.08, 02.09, 02.10, 02.12, 03.13, 02.14, 02.16, 02.17, 02.19, 02.20, 02.21, 02.24, 03.01, 03.04, 03.05, 23.01
BONDS	01.10, 01.12, 02.02, 02.09, 03.00, 03.03, 03.04, 03.05, 03.07, 03.08, 03.10, 03.12, 03.13, 27.06
CHANGE ORDER	01.11, 01.19, 04.01, 09.04, 11.07, 16.02, 16.06, 16.07, 21.06, 21.08, 21.10, 21.11, 29.06, 33.07
CLAIMS	02.15, 04.05, 09.05, 14.01, 16.04, 16.05, 21.16, 24.01
CLOSING ROADS COMMENCE WORK	16.06, 16.07, 16.15 04.04, 07.04, 09.02, 11.02, 14.02, 16.13, 24.02
COMPLETION OF WORK OR PROJECT	01.14, 02.15, 08.03, 09.01, 09.04, 11.00, 11.03, 12.01, 13.01, 13.11, 20.01, 25.01, 28.02, 29.04
CONDITIONS AT JOB SITE	16.17
CONTRACT DOCUMENTS	01.03, 01.03, 01.10, 01.12, 01.13, 01.16, 01.17, 01.18, 01.19, 01.29, 01.22, 01.25, 01.30, 01.33, 02.02, 02.05, 02.13, 02.17, 02.18, 02.23, 03.01, 03.02, 04.01, 04.02, 04.03, 04.04, 04.05, 06.00, 06.01, 06.02, 06.03, 07.02, 07.03, 07.05, 08.01, 10.06, 11.03, 13.01, 13.02, 21.01, 21.09, 21.10, 21.11, 28.01, 28.04, 33.01
CONTRACT PRICE	01.11, 01.13, 03.05, 04.01, 12.01, 14.02, 21.06, 21.10, 21.11, 27.05, 28.01, 28.02, 28.03, 28.08

CONTRACT TIME	01.11, 01.14, 01.22, 10.06, 11.01, 21.06, 29.04
CONTRACTOR - (Defined)	01.15
DAMAGE	02.15, 03.05, 03.12, 04.05, 09.05, 11.09, 13.11, 14.01, 14.02, 16.01, 16.02, 16.03, 16.04, 16.05, 19.01, 19.03, 20.01, 20.08, 23.03, 24.01, 24.07, 24.12, 26.03, 28.05, 28.01, 28.10, 33.07
DEFECTIVE WORK	01.16, 10.03, 21.00, 21.01, 21.07, 21.08, 21.09, 21.10, 28.03
DELAYS	07.02, 11.05, 11.09, 12.01, 16.07, 18.02, 19.01, 28.04
DRAWINGS	01.12, 01.17, 02.13, 02.17, 02.23, 06.01, 06.02, 06.03, 13.15, 22.02, 01.27, 01.33, 03.12, 04.01, 06.02, 09.01, 10.01, 10.02, 11.07, 13.00, 13.01, 13.03, 13.05, 13.11, 13.12, 13.15, 14.02, 14.07, 14.08, 14.09, 16.09, 16.13, 21.01, 21.06, 21.07, 21.14, 24.07, 27.05, 27.07, 28.01, 28.05, 28.10, 29.03, 13.00, 13.11
ENGINEER STATUS (NOT APPLICABLE)	15.00
EXTRA WORK	03.09, 14.00, 14.03, 14.04, 14.05, 14.08, 14.09, 14.10, 14.11, 14.12, 16.01, 22.02
FAILURE OF CONTRACTOR	03.10, 04.05, 06.02, 09.05, 10.01, 10.03, 13.10, 16.03, 20.01, 24.09, 27.02, 28.10
FAILURE OF OWNER	02.13
FAILURE OF SUCCESSFUL BIDDER	02.13, 02.17, 03.04
FIELD ORDER	01.18
FORCE ACCOUNT	14.04, 14.05, 14.11, 14.12
FUNDING	33.09
INDEMNIFY / HOLD HARMLESS	02.15, 03.05, 04.05, 13.11, 16.04, 16.05, 20.02, 24.06, 24.09
INDEMNIFYING INFRINGEMENT CLAUSE	02.15
INJURIES	16.00, 16.01, 16.02, 19.01, 19.03, 20.01, 24.02, 24.07
INSPECTION FEES	13.12
INSPECTIONS, GENERALLY	01.16, 13.05, 16.13, 21.00, 21.03, 21.04, 21.05, 21.06, 21.14, 21.15, 28.04, 29.02, 29.03
INSURANCE	01.05, 14.05, 16.13, 24.00 - 12, 27.07, 28.05
INTENTION OF CONTRACT DOCUMENTS	06.00, 06.01
INTENTION OF GENERAL CONDITIONS	31.00

LABOR	01.33, 03.12, 09.01, 13.00, 13.01, 13.02, 13.08, 13.10, 13.11, 13.12, 14.05, 16.06, 16.07, 21.06, 21.07, 21.15, 27.01, 28.10, 29.03
LAWS	01.10, 01.20, 02.06, 02.13, 02.14, 02.16, 02.20, 03.01, 03.10, 13.12, 16.06, 16.07, 20.02, 21.02, 21.09, 27.01, 29.06, 33.00, 33.01, 33.08
MATERIALS	01.33, 03.12, 04.01, 06.02, 07.01, 09.01, 10.01, 10.02, 13.00, 13.01, 13.03, 13.04, 13.05, 13.12, 13.13, 13.15, 14.01, 14.11, 20.01, 12.01, 21.07, 21.14, 21.15, 23.03, 27.01, 27.05, 27.07, 28.01, 28.05, 28.07, 28.08, 28.10
MODIFICATIONS	01.12, 01.19, 02.12, 02.13, 06.01, 06.02, 24.07, 32.02
NOTICE OF AWARD	01.20, 03.01, 03.04, 04.01
NOTICE OF DEFAULT	12.01, 33.08
NOTICE TO BIDDER	2.21
NOTICE TO CONTRACTOR	01.12, 01.21, 21.11, 30.01
NOTICE TO OWNER	13.07, 24.06, 27.07
NOTICE TO PROCEED	01.22, 09.02, 11.01, 11.03
OBSTRUCTIONS	16.09, 16.11, 16.15, 23.00, 23.01, 23.02
OCCUPANCY	25.00
ORAL INTERPRETATIONS	02.13
OWNER - (Defined)	01.23
PAYMENT	01.30, 03.10, 03.12, 03.13, 04.12, 09.03, 11.04, 11.09, 14.04, 14.12, 16.02, 16.16, 19.02, 21.07, 21.08, 21.09, 21.10, 21.11, 21.16, 24.02, 24.03, 24.12, 27.01, 27.07, 28.00, 28.01, 28.02, 28.03, 28.04, 28.05, 28.06, 28.08, 28.09, 28.10, 29.00, 29.03, 29.05, 29.07
PERMITS	13.00, 13.12, 16.13, 28.08
PRICE	02.05, 14.02, 14.03, 14.04, 14.05, 22.01
PROGRESS PAYMENT	01.06, 28.06
PROGRESS SCHEDULE	09.03, 09.05, 21.11
PROGRESS OF WORK	09.00, 11.09, 13.07, 16.01, 16.12, 21.11, 21.12, 22.02, 27.02
PROJECT	01.24, 01.29, 01.30, 02.04, 03.07, 06.01, 07.03, 10.02, 11.04, 11.06, 13.08, 13.13, 14.08, 14.11, 16.15, 24.07, 24.11, 28.07, 29.03, 29.07
PROJECT REPRESENTATIVE	01.23, 21.16

PROPERTY	16.00, 16.01, 16.02, 16.03, 16.12, 16.13, 16.17, 18.01, 19.00, 19.01, 19.02, 19.03, 23.03, 24.01, 24.07, 26.03, 28.10, 29.08, 33.05
PROPOSAL	01.26, 02.00, 02.01, 02.03, 02.05, 02.06, 02.07, 02.08, 02.09, 02.10, 02.11, 02.12, 02.14, 02.18, 02.21, 02.22, 11.03, 12.01, 14.01, 14.02, 14.03, 19.02, 23.02, 28.08
PROTESTS	33.10
PUNCH LIST	29.03, 29.04
QUANTITIES OF ESTIMATES	14.00, 14.01, 14.02, 14.04
RAILROADS	16.13, 19.01
RECORD DRAWINGS	08.00, 18.01, 18.02, 18.03
RECORDATION OF DOCUMENTS	03.13, 28.03, 29.05, 29.06
REJECTION OF BIDS	02.03, 02.07, 02.08, 02.10, 02.14, 03.01
RENTAL OF EQUIPMENT	14.07, 14.09
RIGHTS OF WAY	18.00
SAFETY	16.01, 16.07, 16.14, 16.17
SANITARY PROVISIONS	13.01, 17.00
SCHEDULE OF WORK	09.03, 09.04, 9.05, 11.06, 13.09
SEVERABILITY	32.01, 32.02
SHOP DRAWINGS	01.27, 06.03, 07.00, 07.01, 07.02, 07.03, 07.04, 07.05
SITE	02.17, 7.04, 13.05, 13.07, 13.11, 14.06, 16.09, 21.08, 21.09, 21.12, 22.02, 23.01, 24.07
SOLICITATION OF EMPLOYMENT	13.14
SPECIFICATIONS	01.01, 01.02, 01.05, 01.07, 01.12, 01.28, 02.13, 02.17, 02.23, 03.06, 03.09, 03.10, 03.13, 06.01, 06.02, 06.03, 07.04, 07.05, 11.03, 13.05, 13.15, 20.01, 21.12, 22.02, 28.01, 28.04, 32.01
SUBCONTRACTOR	01.27, 01.29, 04.01, 04.02, 04.03, 04.04, 04.05, 16.02, 16.04, 16.05, 20.01, 20.02, 21.07, 24.01, 24.07, 27.01, 28.07
SUBCONTRACTS	04.00, 13.09
SUBSURFACE CONDITIONS	02.17, 22.00, 22.01, 22.02
SUBSTANTIAL COMPLETION	01.30, 11.04, 21.09, 28.04, 29.01, 29.02, 29.03, 29.04, 29.06
SUPERINTENDENT	01.21, 01.31, 13.07, 14.05
SUPERVISION	13.01, 13.06



SURETY	01.05, 01.10, 02.09, 03.05, 03.06, 03.07, 03.08, 03.09, 03.11, 03.12, 04.05, 05.01, 14.03, 27.03, 27.05
SURVEY	13.02, 26.00, 26.01
TAXES	02.05, 13.00, 13.12, 13.13, 14.05, 28.07, 28.08, 28.10
TERMINATION OF CONTRACT	13.10, 24.09, 27.00, 27.01, 27.02, 27.03, 27.04, 27.05, 27.06, 27.07
TESTS, GENERALLY	21.00, 21.02, 21.03, 21.04, 21.05, 21.06
TIME	01.32
TRAFFIC	16.06, 16.07, 16.10, 16.15, 16.16
TRAFFIC HAZARDS	16.16
TREES AND SHRUBS	19.02
VERBAL INSTRUCTIONS	21.16
WAIVERS	24.06, 29.03, 33.08
WARNING DEVICES	16.13, 16.14, 16.15
WARRANTY	21.01, 21.08, 21.09, 33.04, 33.06
WORK	01.31, 20.01
WORK BY OTHERS	10.03, 10.04, 10.05
WORK BY OWNER	10.02, 10.04, 10.05
WORK FOR OTHER, RESTRICTIONS	16.12
WORK ORDER	28.01

## 01.00 DEFINITIONS OF TERMS

Whenever used in these General Conditions or in other Contract Documents, the following terms shall have the meanings indicated, and these shall be applicable to both the singular and plural thereof.

- 01.01 A.A.S.H.T.O American Association of State Highway and Transportation Officials. When A.A.S.H.T.O. is referred to in these Specifications it takes the meaning of the specification for materials and methods of testing specified by this association and the specification stated is considered to be a part of the Specifications as if written herein in full.
- 01.02 A.C.I American Concrete Institute. When A.C.I. is referred to in these Specifications it takes the meaning of the specification for materials and methods of testing specified by this institute and the specification stated is considered to be a part of the Specifications as if written herein in full.
- 01.03 Addenda Written or graphic instruments issued prior to the opening of bids which clarify, correct, modify or change the bidding or Contract Documents.
- 01.04 Advertisement The written instrument issued by the Owner at the request of the Owner used to notify the prospective bidder of the nature of the Work. It becomes part of the Contract Documents.
- 01.05 Agreement The written agreement or contract between the Owner and the Contractor covering the Work to be performed and the price that the Owner will pay. Other documents, including the Proposal, Addenda, Specifications, plans, surety, insurance, etc., are made a part thereof.
- 01.06 Application for Payment The form furnished by the Owner which is to be used by the Contractor in requesting incremental (progress) payments and which is to include information required by Section 28.01 and an affidavit of the Contractor. The affidavit shall stipulate that progress payments theretofore received from the Owner on account of the Work have been applied by Contractor to discharge in full of all Contractor's obligations reflected in prior applications for payment.
- 01.07 A.S.T.M. American Society of Testing Materials. When A.S.T.M. is referred to in these Specifications it takes the meaning of the specification for materials and methods of testing specified by this society and the specification stated is considered to be a part of the Specifications as if written herein in full.
- 01.08 Bid The offer or Proposal of the Bidder submitted on the prescribed form setting forth all the prices for the Work to be performed.
- 01.09 Bidder Any person, partnership, firm or corporation submitting a Bid for the Work.
- 01.10 Bonds Bid, performance and payment bonds and other instruments of security, furnished by the Contractor and its surety in accordance with the Contract Documents and Louisiana law.
- 01.11 Change Order A written order to the Contractor signed by the Owner authorizing an addition, deletion or revision in the Work, or an adjustment in the Contract Price or the Contract Time after execution of the Agreement.
- 01.12 Contract Documents The Agreement, Addenda, Contractor's Bid and any documentation accompanying or post-bid documentation when attached as an exhibit, the Bonds, these General Conditions, the Advertisement for Bid, Notice to Contractor, all supplementary conditions, the Specifications, the Drawings, together with all Modifications issued after the execution of the Agreement.
- 01.13 Contract Price The total monies payable to the Contractor under the Contract Documents.
- 01.14 Contract Time The number of consecutive calendar days stated in the Agreement for the completion of the Work.

- 01.15 Contractor The person, firm, corporation or provider with whom the Owner has executed the Agreement.
- 01.16 Defective Work When work which is unsatisfactory, faulty or deficient for any reason whatsoever, or does not conform to the Contract Documents, or does not meet the requirements of any inspection, test or approval referred to in the Contract Documents, or has been damaged prior to the Owner's recommendation or acceptance.
- 01.17 Drawings The Drawings and plans which show the character and scope of the Work to be performed and which have been prepared or approved by the Owner and are referred to in the Contract Documents.
- 01.18 Field Order A written order issued by the Owner or his agent which clarifies or interprets the Contract Documents.
- 01.19 Modification (a) A written amendment of the Contract Documents signed by both parties, (b) A Change Order, (c) A written clarification or interpretation issued by the Owner or his agent. Modification may only be issued after execution of the Agreement.
- 01.20 Notice of Award The written notice by Owner to the lowest responsible Bidder stating that upon compliance of the conditions enumerated in the Notice of Award, or enumerated in the Bid documents, the Owner will deliver the Contract Documents for signature. The time for the delivery of the Contract Documents can be extended in conformance with Louisiana Law.
- 01.21 Notice to Contractor Instructions, written or oral given by Owner to Contractor and deemed served if given to the Contractor's superintendent, foreman or mailed to Contractor at his last known place of business.
- 01.22 Notice to Proceed A written notice given by the Owner fixing the date on which the Contract Time will commence, and on which date the Contractor shall start to perform his obligation under the Contract Documents. Upon mutual consent by both parties, the Notice to Proceed may be extended.
- 01.23 Owner St. Tammany Parish Government, acting herein through its duly constituted and authorized representative, including but not limited to the Office of the Parish President or its designee, its Chief Administrative Officer, and/or Legal Counsel. St. Tammany Parish Government (hereinafter, the "Parish") and Owner may be used interchangeably.
- 01.24 Project The entire construction to be performed as provided in the Contract Documents.
- 01.25 Project Representative The authorized representative of the Owner who is assigned to the Project or any parts thereof.
- 01.26 Proposal The Bid submitted by the Bidder to the Owner on the Proposal form setting forth the Work to be done and the price for which the Bidder agrees to perform the Work.
- 01.27 Shop Drawings All drawings, diagrams, illustrations, brochures, schedules and other data which are prepared by the Contractor, Subcontractor, Manufacturer, Supplier or Distributor and which illustrate the equipment, material or some portion of the Work.
- 01.28 Specifications The Instructions to Bidders, these General Conditions, the Special Conditions and the Technical Provisions. All of the documents listed in the "Table of Contents."
- 01.29 Subcontractor An individual, firm or corporation having a direct Contract with the Contractor or with any other Subcontractor for the performance of a part of the Project Work.
- 01.30 Substantial Completion The date as certified by the Owner or its agent when the construction of the Project or a specified part thereof is sufficiently complete in accordance with the Contract Documents so that the Project or specified part can be utilized for the purposes for which it was intended; or if there is no such certification, the date when final payment is due in accordance with Section 28.

- 01.31 Superintendent Contractor's site representative. The person on the site who is in full and complete charge of the Work.
- 01.32 Time Unless specifically stated otherwise, all time delays shall be calculated in calendar days.
- 01.33 Work Any and all obligations, duties and responsibilities necessary to the successful completion of the Project assigned to or undertaken by the Contractor under the Contract Documents, usually including the furnishing of all labor, materials, equipment and other incidentals.
- 01.34 The terms "he/himself" may be used interchangeably with "it/itself."

## 02.00 PROPOSAL

- 02.01 All papers bound with or attached to the Proposal Form are a necessary part thereof and must not be detached.
- 02.02 For submitting Bids, the only forms allowed shall be the "Louisiana Uniform Public Work Bid Form", "Louisiana Uniform Public Works Bid Form Unit Price Form" (if necessary), the Bid Bond, and written evidence of authority of person signing the bid. Necessary copies of the Louisiana Uniform Public Work Forms will be furnished for Bidding. Bound sets of the Contract Documents are for Bidder's information and should not be used in submitting Bids.
- 02.03 Proposal forms must be printed in ink or typed, unless submitted electronically. Illegibility or ambiguity therein may constitute justification for rejection of the Bid.
- 02.04 Each Bid must be submitted in a sealed envelope, unless submitted electronically. The outside of the envelope shall show the name and address of the Bidder, the State Contractor's License Number of the Bidder (if work requires contractor's license), and the Project name and number for which the Bid is submitted, along with the Bid number.
- 02.05 The price quoted for the Work shall be stated in words and figures on the Bid Form, and in numbers only on the Unit Price Form. The price in the Proposal shall include all costs necessary for the complete performance of the Work in full conformity with the conditions of the Contract Documents, and shall include all applicable Federal, State, Parish, Municipal or other taxes. The price bid for the items listed on the Unit Price Form will include the cost of all related items not listed, but which are normally required to do the type of Work bid.
- 02.06 The Bid shall be signed by the Bidder. The information required on the Louisiana Uniform Public Work Bid Form must be provided. Evidence of agency, corporate, or partnership authority is required and shall be provided in conformance with LSA-R.S. 38:2212(B).
- 02.07 Only the Contractors licensed by the State to do the type of Work involved can submit a Proposal for the Work. The envelope containing the Proposal shall have the Contractor's license number on it. Failure to be properly licensed constitutes authority by the Owner for rejection of Bid.
- 02.08 Bidders shall not attach any conditions or provisions to the Proposal. Any conditions or provisions so attached may, at the sole option of the Owner, cause rejection of the Bid or Proposal.
- 02.09 A Bid Guarantee of five percent (5%) of the amount of the total Bid, including Alternates, must accompany the Proposal and, at the option of the Bidder, may be a cashier's check, certified check or a satisfactory Bid Bond. The Bid Guarantee must be attached to the Louisiana Uniform Public Work Bid Form. No Bid will be considered unless it is so guaranteed. Cashier's check or certified check must be made payable to the order of the Owner. Cash deposits will not be accepted. The Owner reserves the right to cash or deposit the cashier's check or certified check. Such guarantees shall be made payable to the Parish of St. Tammany. In accordance with LSA-R.S. 38:2218(C), if a bid bond is used, it shall be written by a surety or insurance company currently on the U.S. Department of the Treasury Financial Management Service list of approved bonding companies which is

published annually in the Federal Register, or by a Louisiana domiciled insurance company with at least an A- rating in the latest printing of the A.M. Best's Key Rating Guide to write individual bonds up to ten percent of policyholders' surplus as shown in the A.M. Best's Key Rating Guide, or by an insurance company in good standing licensed to write bid bonds which is either domiciled in Louisiana or owned by Louisiana residents. It is **not** required to be on any AIA form.

- 02.10 Bid securities of the three (3) lowest Bidders will be retained by the Owner until the Contract is executed or until final disposition is made of the Bids submitted. Bid securities of all other Bidders will be returned promptly after the canvas of Bids. Bids shall remain binding for forty-five (45) days after the date set for Bid Opening. The Parish shall act within the forty-five (45) days to award the contract to the lowest responsible bidder or reject all bids as permitted by Public Bid Law. However, the Parish and the lowest responsible bidder, by mutual written consent, may agree to extend the deadline for award by one or more extensions of thirty (30) calendar days. In the event the Owner issued the Letter of Award during this period, or any extension thereof, the Bid accepted shall continue to remain binding until the Execution of the Contract.
- 02.11 A Proposal may be withdrawn at any time prior to the scheduled closing time for receipt of Bids, provided the request is in writing, executed by the Bidder or its duly authorized representative and is filed with the Owner prior to that time. When such a request is received, the Proposal will be returned to the Bidder unopened.
- 02.12 Written communications, over the signature of the Bidder, to modify Proposals will be accepted and the Proposal corrected in accordance therewith if received by the Owner prior to the scheduled closing time for receipt of Bids. Oral, telephonic or telegraphic Modifications will not be considered.
- 02.13 No oral interpretation obligating the Owner will be made to any Bidder as to the meaning of the Drawings, Specifications and Contract Documents. Every request for such an interpretation shall be made in writing and addressed and forwarded to the Owner. No inquiry received within seven (7) days prior to the day fixed for opening of the Bids shall be given consideration. Every interpretation made to the Bidder shall be in the form of an addendum to the Specifications. All such Addenda shall become part of the Contract Documents. Failure of Bidder to receive any such interpretation shall not relieve any Bidder from any obligation under this Bid. All Addenda shall be issued in accordance with the Public Bid Law, LSA-R.S. 38:2212(O)(2)(a) and (b).
- 02.14 The Owner reserves the right to reject any or all Bids for just cause in accordance with the Public Bid Law, LSA-R.S. 38:2214(B). Incomplete, informal or unbalanced Bids may be rejected. Reasonable grounds for belief that any one Bidder is concerned directly or indirectly with more than one Bid will cause rejection of all Bids wherein such Bidder is concerned. If required, a Bidder shall furnish satisfactory evidence of its competence and ability to perform the Work stipulated in its Proposal. Incompetence will constitute cause for rejection. If the Parish determines that the bidder is not responsive or responsible for any reason whatsoever, the bid may be rejected in accordance with State law.
- 02.15 The Contractor shall indemnify and hold harmless the Owner from any and all suits, costs, penalties or claims for infringement by reason of use or installation of any patented design, device, material or process, or any trademark and copyright in connection with the Work agreed to be performed under this Contract, and shall indemnify and hold harmless the Owner for any costs, expenses and damages which it may be obliged to pay by reason of any such infringement at any time during the prosecution or after completion of the Work.
- 02.16 Bidders shall familiarize themselves with and shall comply with all applicable Federal and State Laws, municipal ordinances and the rules and regulations of all authorities having jurisdiction over construction of the Project, which may directly or indirectly affect the Work or its prosecution. These laws and/or ordinances will be deemed to be included in the Contract, as though herein written in full.
- 02.17 Each Bidder shall visit the site of the proposed Work and fully acquaint itself with all surface and subsurface conditions as they may exist so that it may fully understand this Contract. Bidder shall also thoroughly examine and be familiar with drawings, Specifications and Contract Documents. The failure or omission of any Bidder to receive or examine any form instrument, Drawing or document or to visit the site and acquaint

itself with existing conditions, shall in no way relieve any Bidder from any obligation with respect to its Bid and the responsibility in the premises.

- 02.18 The standard contract form enclosed with the Proposal documents is a prototype. It is enclosed with the Contract Documents for the guidance of the Owner and the Contractor. It has important legal consequences in all respects and consultation with an attorney is encouraged. Contractor shall be presumed to have consulted with its own independent legal counsel.
- 02.19 When one set of Contract plans show the Work to be performed by two or more prime Contractors, it is the responsibility of each Bidder to become knowledgeable of the Work to be performed by the other where the Work upon which this bid is submitted is shown to come into close proximity or into conflict with the Work of the other. In avoiding conflicts, pressure pipe lines must be installed to avoid conflict with gravity pipe lines and the Bidder of the smaller gravity pipe line in conflict with the larger gravity pipe line must include in his Bid the cost of a conflict box at these locations. The location of and a solution to the conflicts do not have to be specifically noted as such on the plans.
- 02.20 Bidder shall execute affidavit(s) attesting compliance with LSA-R.S. 38:2212.10, 38:2224, 38:2227, each as amended, and other affidavits as required by law, prior to execution of the contract.
- 02.21 Sealed Proposals (Bid) shall be received by St. Tammany Parish Government at the office of St. Tammany Parish Government, Department of Procurement, 21454 Koop Drive, Suite 2-F, Mandeville, LA 70471, until the time and date denoted in Notice to Bidders, at which time and place the Proposals (Bids), shall be publicly opened and read aloud to those present. In accordance with LSA-R.S. 38-2212(A)(3)(c)(i), the designer's final estimated cost of construction shall be read aloud upon opening bids. Sealed Proposals (Bids) may also be mailed by certified mail to St. Tammany Parish Government, Department of Procurement, 21454 Koop Drive, Suite 2-F, Mandeville, LA 70471, and must be received before the bid opening. Bids may also be submitted electronically. Information concerning links for electronic bidding is contained in the Notice to Bidders.
- 02.22 Proposals (Bids) shall be executed on Forms furnished and placed in a sealed envelope, marked plainly and prominently as indicated in the Notice to Bidders, and these General Conditions, and addressed:

St. Tammany Parish Government  
Department of Procurement  
21454 Koop Drive, Suite 2-F  
Mandeville, LA 70471

- 02.23 Complete sets of Drawings, Specifications, and Contract Documents may be secured at the Office of the Owner. See Notice to Bidders for deposit schedule.
- 02.24 The successful bidder shall be required to post in each direction a public information sign, 4' x 8' in size, at the location of the project containing information required by the Owner. The Owner shall supply this information.

03.00 AWARD, EXECUTION OF DOCUMENTS, BONDS, ETC.

- 03.01 The award of the Contract, if it is awarded, will be to the lowest responsible Bidder, in accordance with State Law. No award will be made until the Owner has concluded such investigations as it deems necessary to establish the responsibility, qualifications and financial ability and stability of the Bidder to do the Work in accordance with the Contract Documents to the satisfaction of the Owner within the time prescribed as established by the Department based upon the amount of work to be performed and the conditions of same. The written contract and bond shall be issued in conformance with LSA-R.S. 38:2216. The Owner reserves the right to reject the Bid of any Bidder in accordance with the Public Bid Law, LSA-R.S. 38:2214. If the Contract is awarded, the Owner shall give the successful Bidder written notice of the award within forty-five (45) calendar days after the opening of the Bids in conformance with LSA-R.S. 38:2215(A), or any extension as authorized thereunder.

- 03.02 At least three counterparts of the Agreement and of such other Contract Documents as practicable shall be signed by the Owner and the Contractor. The Owner shall identify those portions of the Contract Documents not so signed and such identification shall be binding on both parties. The Owner and the Contractor shall each receive an executed counterpart of the Contract Documents.
- 03.03 Prior to the execution of the Agreement, the Contractor shall deliver to the Owner the required Bonds.
- 03.04 Failure of the successful Bidder to execute the Agreement and deliver the required Bonds within twenty (20) days of the Notice of the Award shall be just cause for the Owner to annul the award and declare the Bid and any guarantee thereof forfeited.
- 03.05 In order to ensure the faithful performance of each and every condition, stipulation and requirement of the Contract and to indemnify and save harmless the Owner from any and all damages, either directly or indirectly arising out of any failure to perform same, the successful Bidder to whom the Contract is awarded shall furnish a surety Bond in an amount of at least equal to one hundred percent (100%) of the Contract Price. The Contract shall not be in force or binding upon the Owner until such satisfactory Bond has been provided to and approved by the Parish. The cost of the Bond shall be paid for by the Contractor unless otherwise stipulated in the Special Provisions.
- 03.06 No surety Company will be accepted as a bondsman who has no permanent agent or representative in the State upon whom notices referred to in the General Conditions of these Specifications may be served. Services of said notice on said agent or representative in the State shall be equal to service of notice on the President of the Surety Company, or such other officer as may be concerned.
- 03.07 In conformance with LSA-R.S. 38:2219(A)(1)(a), (b), and (c):

Any surety bond written for a public works project shall be written by a surety or insurance company currently on the U.S. Department of the Treasury Financial Management Service list of approved bonding companies which is published annually in the Federal Register, or by a Louisiana domiciled insurance company with at least an A- rating in the latest printing of the A.M. Best's Key Rating Guide, to write individual bonds up to ten percent of policyholders' surplus as shown in the A.M. Best's Key Rating Guide or by an insurance company that is either domiciled in Louisiana or owned by Louisiana residents and is licensed to write surety bonds.

For any public works project, no surety or insurance company shall write a bond which is in excess of the amount indicated as approved by the U.S. Department of the Treasury Financial Management Service list or by a Louisiana domiciled insurance company with an A- rating by A.M. Best up to a limit of ten percent of policyholders' surplus as shown by A.M. Best; companies authorized by this Paragraph who are not on the treasury list shall not write a bond when the penalty exceeds fifteen percent of its capital and surplus, such capital and surplus being the amount by which the company's assets exceed its liabilities as reflected by the most recent financial statements filed by the company with the Department of Insurance.

In addition, any surety bond written for a public works project shall be written by a surety or insurance company that is currently licensed to do business in the state of Louisiana. All contractors must comply with any other applicable provisions of LSA-R.S. 38:2219.

- 03.08 Should the Contractor's Surety, even though approved and accepted by the Owner, subsequently remove its agency or representative from the State or become insolvent, bankrupt, or otherwise fail, the Contractor shall immediately furnish a new Bond in another company approved by the Owner, at no cost to the Owner. The new Bond shall be executed under the same terms and conditions as the original Bond. The new bond shall be submitted within thirty (30) days of such time as the Owner notifies Contractor or from the time Contractor learns or has reason to know that the original surety is no longer financially viable or acceptable to the Parish, whichever occurs first. In the event that Contractor fails or refuses to timely secure additional surety, then the Owner may secure such surety and thereafter deduct such cost or expense from any sum due or to become due Contractor.

- 03.09 The Contractor's bondsman shall obligate itself to all the terms and covenants of these Specifications and of contracts covering the Work executed hereunder. The Owner reserves the right to do Extra Work or make changes by altering, adding to deducting from the Work under the conditions and in the manner herein before described without notice to the Contractor's surety and without in any manner affecting the liability of bondsman or releasing it from any of its obligations hereunder.
- 03.10 The Bond shall also secure for the Owner the faithful performance of the Contract in strict accordance with plans and Specifications. It shall protect the Owner against all lien laws of the State and shall provide for payment of reasonable attorney fees for enforcement of Contract and institution or concursus proceedings, if such proceedings become necessary. Likewise, it shall provide for all additional expenses of the Owner occurring through failure of the Contractor to perform.
- 03.11 The surety of the Contractor shall be and does hereby declare and acknowledge itself by acceptance to be bound to the Owner as a guarantor, jointly and in solido, with the Contractor, for fulfillment of terms of Section 03.00.
- 03.12 The performance Bond and Labor and Material Bond forming part of this Contract shall be continued by Contractor and its Surety for a period of one (1) year from date of acceptance of this Contract by Owner to assure prompt removal and replacement of all defective material, equipment, components thereof, workmanship, etc., and to assure payment of any damage to property of Owner or others as a result of such defective materials, equipment, workmanship, etc.
- 03.13 Contractor shall pay for the cost of recording the Contract and Bond and the cost of canceling same. Contractor shall also secure and pay for all Clear Lien and Privilege Certificates (together with any updates) which will be required before any final payment is made, and that may be required before any payment, at the request of the Owner, its representative, agent, architect, engineer and the like. All recordation and Clear Lien and Privilege Certificate requirements shall be in accordance with those requirements noted herein before in contract Specifications.

#### 04.00 SUBCONTRACTS

- 04.01 Contractor shall be fully responsible for all acts and omissions of its Subcontractors and of persons and organizations for whose acts any of them may be liable to the same extent that it is responsible for the acts and omissions of persons directly employed by it. Nothing in the Contract Documents shall create any contractual relationship between Owner and any Subcontractor or other person or organization having a direct Contract with Contractor, nor shall it create any obligation on the part of the Owner to pay or to see to the payment of any monies due any Subcontractor.
- 04.02 Nothing in the Contract Documents shall be construed to control the Contractor in dividing the Work among approved Subcontractors or delineating the Work to be performed by any trade.
- 04.03 The Contractor agrees to specifically bind every Subcontractor to all of the applicable terms and conditions of the Contract Documents prior to commencing Work. Every Subcontractor, by undertaking to perform any of the Work, shall thereby automatically be deemed bound by such terms and conditions.
- 04.04 The Contractor shall indemnify and hold harmless the Owner and their agents and employees from and against all claims, damages, losses and expenses including Attorney's fees arising out of or resulting from the Contractor's failure to bind every Subcontractor and Contractor's surety to all of the applicable terms and conditions of the Contract Documents.

#### 05.00 ASSIGNMENT



05.01 Neither party to this Contract shall assign or sublet its interest in this Contract without prior written consent of the other, nor shall the Contractor assign any monies due or to become due to it under this Contract without previous written consent of the Owner, nor without the consent of the surety unless the surety has waived its right to notice of assignment.

06.00 CORRELATION, INTERPRETATION AND INTENT OF CONTRACT DOCUMENTS.

06.01 It is the intent of the Specifications and Drawings to describe a complete Project to be constructed in accordance with the Contract Documents. The Contract Documents comprise the entire Agreement between Owner and Contractor. Alterations, modifications and amendments shall only be in writing between these parties.

06.02 The Contract Documents are intended to be complimentary and to be read *in pari materii*, and what is called for by one is as binding as if called for by all. If Contractor finds a conflict, error or discrepancy in the Contract Documents, it shall call it to the Owner's attention, in writing, at once and before proceeding with the Work affected thereby; however, it shall be liable to Owner for its failure to discover any conflict, error or discrepancy in the Specifications or Drawings. In resolving such conflicts, errors and discrepancies, the documents shall be given precedence in the following order: Agreement, Modifications, Addenda, Special Conditions, General Conditions, Construction Specifications and Drawings. The general notes on the plans shall be considered special provisions. Figure dimensions on Drawings shall govern over scale dimensions and detail Drawings shall govern over general Drawings. Where sewer connections are shown to fall on a lot line between two lots, the Contractor shall determine this location by measurement not by scale. Any Work that may reasonably be inferred from the Specifications or Drawings as being required to produce the intended result shall be supplied whether or not it is specifically called for. Work, materials or equipment described herein which so applied to this Project are covered by a well-known technical meaning or specification shall be deemed to be governed by such recognized standards unless specifically excluded.

06.03 Unless otherwise provided in the Contract Documents, the Owner will furnish to the Contractor (free of charge not to exceed ten (10) copies) Drawings and Specifications for the execution of Work. The Drawings and Specifications are the property of the Owner and are to be returned to it when the purpose for which they are intended have been served. The Contractor shall keep one copy of all Drawings and Specifications, including revisions, Addenda, details, Shop Drawings, etc. on the Work in good order and available to the Owner or the regulatory agency of the governmental body having jurisdiction in the area of the Work.

07.00 SHOP DRAWINGS, BROCHURES AND SAMPLES

07.01 After checking and verifying all field measurements, Contractor shall submit to Owner for approval, five copies (or at Owner's option, one reproducible copy) of all Shop Drawings, which shall have been checked by and stamped with the approval of Contractor and identified as Owner may require. The data shown on the Shop Drawings will be complete with respect to dimensions, design criteria, materials of construction and the like to enable Owner to review the information as required.

07.02 Contractor shall also submit to Owner, for review with such promptness as to cause no delay in Work, all samples as required by the Contract Documents. All samples will have been checked by and stamped with the approval of Contractor identified clearly as to material, manufacturer, any pertinent catalog numbers and the use for which intended. At the time of each submission, Contractor shall in writing call Owner's attention to any deviations that the Shop Drawings or samples may have from the requirements of the Contract Documents.

07.03 Owner will review with reasonable promptness Shop Drawings and samples, but its review shall be only for conformance with the design concept of the Project and for compliance with the information given in the Contract Documents. The review of a separate item as such will not indicate approval of the assembly in which the item functions. Contractor shall make any corrections required by Owner and shall return the required number of corrected copies of Shop Drawings and resubmit new samples for review. Contractor shall direct specific attention in writing or on resubmitted Shop Drawings to revisions other than

the corrections called for by Owner on previous submissions. Contractor's stamp of approval on any Shop Drawing or sample shall constitute a representation to Owner that Contractor has determined and verified all quantities, dimensions, field construction criteria, materials catalog numbers and similar data and thereafter assumes full responsibility for doing so, and that it has reviewed or coordinated each Shop Drawing or sample with the requirements of the Work and the Contract Documents.

- 07.04 Where a Shop Drawing or sample submission is required by the Specifications, no related Work shall be commenced until the submission has been reviewed by Owner. A copy of each reviewed shop Drawing and each inspected sample shall be kept in good order by Contractor at the site and shall be available to Owner.
- 07.05 Owner's review of Shop Drawings or samples shall not relieve Contractor from its responsibility for any deviations from the requirements of the Contract Documents unless Contractor has in writing called Owner's attention to such deviation at the time of submission and Owner has given written approval to the specific deviation, nor shall any review by Owner relieve Contractor from responsibility for errors or omissions in the Shop Drawings. The mere submittal of shop drawings which contain deviations from the requirements of plans, specifications and/or previous submittals in itself does not satisfy this requirement.

#### 08.00 RECORD DRAWINGS

- 08.01 The Contractor shall keep an accurate record in a manner approved by the Owner of all changes in the Contract Documents during construction. In Work concerning underground utilities, the Contractor shall keep an accurate record in a manner approved by the Owner of all valves, fittings, etc. Before the Work is accepted by the Owner, and said acceptance is recorded, the Contractor shall furnish the Owner a copy of this record.
- 08.02 Contractor shall keep an accurate drawing measured in the field to the nearest 0.1' of the location of all sewer house connections. The location shown shall be the end of the connection at the property line measured along the main line of pipe from a manhole.
- 08.03 Contractor shall keep an accurate drawing of the storm water drainage collection system. Inverts to the nearest 0.01' and top of castings shall be shown as well as location of all structures to the nearest 0.1'. Upon completion of the Work, the plan will be given to the Owner.

#### 09.00 PROGRESS OF WORK

- 09.01 Contractor shall conduct the Work in such a professional manner and with sufficient materials, equipment and labor as is considered necessary to ensure its completion within the time limit specified.
- 09.02 The Owner shall issue a Notice to Proceed to the Contractor within twenty (20) calendar days from the date of execution of the Contract. Upon mutual consent by both parties, the Notice to Proceed may be extended. The Contractor is to commence Work under the Contract within ten (10) calendar days from the date the Notice to Proceed is issued by the Owner.
- 09.03 The Contractor, immediately after being awarded the Contract, shall prepare and submit for the Owner's approval an estimated progress schedule for the work to be performed, as well as a construction signing layout for all roads within the project area. The Contractor shall not start work or request partial payment until the work schedule has been submitted to the Owner for approval.
- 09.04 Revisions to the original schedule will be made based on extension of days granted for inclement weather or change orders issued under the contract. No other revision shall be made which affects the original completion or updated completion date, whichever is applicable.
- 09.05 Failure of the Contractor to submit an estimated progress schedule or to complete timely and on schedule the Work shown on the progress schedule negates any and all causes or

claims by the Contractor for accelerated completion damages. These accelerated damage claims shall be deemed forfeited.

09.06 Meetings will be held as often as necessary to expedite the progress of the job. Meetings will be held during normal working hours at the jobsite and shall be mandatory for the Contractor and all Sub-Contractors working on the project. Meetings may be requested by the Owner at any time and at the discretion of the Owner.

#### 10.00 OWNER'S RIGHT TO PROCEED WITH PORTIONS OF THE WORK

10.01 Upon failure of the Contractor to comply with any notice given in accordance with the provisions hereof, the Owner shall have the alternative right, instead of assuming charge of the entire Work, to place additional forces, tools, equipment and materials on parts of the Work. The cost incurred by the Owner in carrying on such parts of the Work shall be payable by the Contractor. Such Work shall be deemed to be carried on by the Owner on account of the Contractor. The Owner may retain all amounts of the cost of such Work from any sum due Contractor or those funds that may become due to Contractor under this Agreement.

10.02 Owner may perform additional Work related to the Project by itself or it may let any other direct contract which may contain similar General Conditions. Contractor shall afford the other contractors who are parties to such different contracts (or Owner, if it is performing the additional Work itself) reasonable opportunity for the introduction and storage of materials and equipment and the execution of Work, and shall properly connect and coordinate its Work with the subsequent work.

10.03 If any part of Contractor's Work depends upon proper execution or results upon the Work of any such other contractor (or Owner), Contractor shall inspect and promptly report to Owner in writing any defects or deficiencies in such Work that render it unsuitable for such proper execution and results. Failure to so report shall constitute an acceptance of the other Work as fit and proper for the relationship of its Work except as to defects and deficiencies which may appear in the other Work after the execution of its Work.

10.04 Whatever Work is being done by the Owner, other Contractors or by this Contractor, the parties shall respect the various interests of the other parties at all times. The Owner may, at its sole discretion, establish additional rules and regulations concerning such orderly respect of the rights of various interests.

10.05 Contractor shall do all cutting, fitting and patching of its Work that may be required to integrate its several parts properly and fit to receive or be received by such other Work. Contractor shall not endanger any Work of others by cutting, excavating or otherwise altering Work and will only alter Work with the written consent of Owner and of the other contractors whose Work will be affected.

10.06 If the performance of additional Work by other contractors or Owner is not noted in the Contract Documents, written notice thereof shall be given to Contractor prior to starting any such additional Work. If Contractor believes that the performance of such additional Work by Owner or others may cause additional expense or entitles an extension of the Contract Time, the Contractor may make a claim therefor. The claim must be in writing to the Owner within thirty (30) calendar days of receipt of notice from the Owner of the planned additional Work by others.

#### 11.00 TIME OF COMPLETION

11.01 The Notice to Proceed will stipulate the date on which the Contractor shall begin work. That date shall be the beginning of the Contract Time charges.

11.02 Contractor shall notify the Owner through its duly authorized representative, in advance, of where Contractor's work shall commence each day. A daily log shall be maintained by Contractor to establish dates, times, persons contacted, and location of work. Specific notice shall be made to the Owner if the Contractor plans to work on Saturday, Sunday, or a Parish approved holiday. If notice is not received, no consideration will be given for inclement weather and same shall be considered a valid work day.

11.03 **NOT APPLICABLE-OMITTED** The Work covered by the Plans, Specifications and Contract Documents must be completed sufficiently for acceptance within the number of calendar days specified in the Proposal and/or the Contract, commencing from the date specified in the Notice to Proceed. It is hereby understood and mutually agreed, by and between the Contractor and the Owner, that the time of completion is an essential condition of this Contract, and it is further mutually understood and agreed that if the Contractor shall neglect, fail or refuse to complete the Work within the time specified, or any proper extension thereof granted by the Owner, then the Contractor does hereby agree, as partial consideration for the awarding of this Contract, to pay the Owner \$500.00 per day as specified in the Contract, not as a penalty, but as liquidated damages for such breach of contract for each and every calendar day that the Contractor shall be in default after the time stipulated in the Contract for completing the Work. It is specifically understood that the Owner shall also be entitled to receive a reasonable attorney fee and all costs in the event that Contractor fails to adhere to this agreement and this contract is referred to counsel for any reason whatsoever. Reasonable attorney fees shall be the prevailing hourly rate of the private sector, and in no event shall the hourly rate be less than \$175.00 per hour. All attorney fees shall be paid to the operating budget of the Office of the Parish President.

11.04 Prior to final payment, the Contractor may, in writing to the Owner, certify that the entire Project is substantially complete and request that the Owner or its agent issue a certificate of Substantial Completion. See Section 29.00.

11.05 The Owner may grant an extension(s) of time to the Contractor for unusual circumstances which are beyond the control of the Contractor and could not reasonably be foreseen by the Contractor prior to Bidding. Any such request must be made in writing to the Owner within seven (7) calendar days following the event occasioning the delay. The Owner shall have the exclusive and unilateral authority to determine, grant, and/or deny the validity of any such claim.

11.06 Extensions of time for inclement weather shall be processed as follows:

Commencing on the start date of each job, the Parish Inspector assigned to same shall keep a weekly log, indicating on each day whether inclement weather has prohibited the Contractor from working on any project within the specific job, based upon the following:

1. Should the Contractor prepare to begin work on any day in which inclement weather, or the conditions resulting from the weather, prevent work from beginning at the usual starting time, and the crew is dismissed as a result, the Contractor will not be charged for a working day whether or not conditions change during the day and the rest of the day becomes suitable for work.
2. If weather conditions on the previous day prevent Contractor from performing work scheduled, provided that no other work can be performed on any project within the package. The Parish Inspector shall determine if it is financially reasonable to require the Contractor to deviate from the schedule and relocate to another location.
3. If the Contractor is unable to work at least 60% of the normal work day due to inclement weather, provided that a normal working force is engaged on the job.

Any dispute of weather conditions as related to a specific job shall be settled by records of the National Weather Service.

11.07 Extensions of time for change orders

When a change order is issued, the Owner and Contractor will agree on a reasonable time extension, if any, to implement such change. Consideration shall be given for, but not limited to, the following:

1. If material has to be ordered;

2. Remobilization and or relocation of equipment to perform task; and
3. Reasonable time frame to complete additional work.

Time extensions for change orders shall be reflected on the official document signed by the Owner and Contractor.

- 11.08 At the end of each month, the Owner or its agent will furnish to the Contractor a monthly statement which reflects the number of approved days added to the contract. The Contractor will be allowed fourteen (14) calendar days in which to file a written protest setting forth in what respect the monthly statement is incorrect; otherwise, the statement shall be considered accepted by the Contractor as correct.
- 11.09 Apart from extension of time for unavoidable delays, no payment or allowance of any kind shall be made to the Contractor as compensation for damages because of hindrance or delay for any cause in the progress of the Work, whether such delay be avoidable or unavoidable.

12.00 LIQUIDATED DAMAGES- NOT APPLICABLE-OMITTED

- 12.01 **NOT APPLICABLE-OMITTED** In case the Work is not completed in every respect within the time that may be extended, it is understood and agreed that per diem deductions of the sum of \$500.00 for liquidated damages, as stipulated in the Proposal and/or Contract, shall be made from the total Contract Price for each and every calendar day after and exclusive of the day on which completion was required, and up to the completion of the Work and acceptance thereof by the Owner. It is understood and agreed that time is of the essence to this Contract, and the above sum being specifically herein agreed upon in advance as the measure of damages to the Owner on account of such delay in the completion of the Work. It is further agreed that the expiration of the term herein assigned or as may be extended for performing the Work shall, *ipso facto*, constitute a putting in default, the Contractor hereby waiving any and all notice of default. The Contractor agrees and consents that the Contract Price, reduced by the aggregate of the entire damages so deducted, shall be accepted in full satisfaction of all Work executed under this Contract. It is further understood and agreed that Contractor shall be liable for a reasonable attorney fee and all costs associated with any breach of this agreement, including but not limited to this subsection. In the event that any dispute or breach herein causes referrals to counsel, then Contractor agrees to pay a reasonable attorney fee at the prevailing hourly rate of the private sector. In no event shall the hourly rate be less than \$175.00 per hour.

13.00 LABOR, MATERIALS, EQUIPMENT, SUPERVISION, PERMITS AND TAXES

- 13.01 The Contractor shall provide and pay for all labor, materials, equipment, supervision, subcontracting, transportation, tools, fuel, power, water, sanitary facilities and all incidentals necessary for the completion of the Work in substantial conformance with the Contract Documents.
- 13.02 The Contractor shall provide competent, suitably qualified personnel to survey and lay out the Work and perform construction as required by the Contract Documents. It shall at all times maintain good discipline and order at the site.
- 13.03 Unless otherwise specifically provided for in the Specifications, all workmanship, equipment, materials, and articles incorporated in the Work covered by this Contract are to be new and of the best grade of their respective kinds for the purpose intended. Samples of materials furnished under this Contract shall be submitted for approval to the Owner when and as directed.
- 13.04 Whenever a material or article required is specified or shown on the plans by using the name of a proprietary product or of a particular manufacturer or vendor, any material or article which shall perform adequately the duties imposed by the general design will be considered equal, and satisfactory, providing the material or article so proposed is of equal substance and function and that all technical data concerning the proposed substitution be approved by the Owner prior to the Bidding. The Owner shall have the exclusive and unilateral discretion to determine quality and suitability in accordance with LSA-R.S. 38:2212(T)(2).

- 13.05 Materials shall be properly and securely stored so as to ensure the preservation of quality and fitness for the Work, and in a manner that leaves the material accessible to inspection. Materials or equipment may not be stored on the site in a manner such that it will interfere with the continued operation of streets and driveways or other contractors working on the site.
- 13.06 The Contractor, by entering into the Contract for this Work, sets itself forth as an expert in the field of construction and it shall supervise and direct the Work efficiently and with its best skill and attention. It shall be solely responsible for the means, methods, techniques, sequences and procedures of construction.
- 13.07 Contractor shall keep on the Work, at all times during its progress, a competent resident Superintendent, who shall not be replaced without written Notice to Owner except under extraordinary circumstances. The Superintendent will be Contractor's representative at the site and shall have authority to act on behalf of Contractor. All communications given to the Superintendent shall be as binding as if given to the Contractor. Owner specifically reserves the right to approve and/or disapprove the retention of a new superintendent, all to not be unreasonably withheld.
- 13.08 Any foreman or workman employed on this Project who disregards orders or instructions, does not perform his Work in a proper and skillful manner, or is otherwise objectionable, shall, at the written request of the Owner, be removed from the Work and shall be replaced by a suitable foreman or workman.
- 13.09 The Contractor and/or its assigned representative shall personally ensure that all subcontracts and divisions of the Work are executed in a proper and workmanlike manner, on scheduled time, and with due and proper cooperation.
- 13.10 Failure of the Contractor to keep the necessary qualified personnel on the Work shall be considered cause for termination of the Contract by the Owner.
- 13.11 Only equipment in good working order and suitable for the type of Work involved shall be brought onto the job and used by the Contractor. The Contractor is solely responsible for the proper maintenance and use of its equipment and shall hold the Owner harmless from any damages or suits for damages arising out of the improper selection or use of equipment. No piece of equipment necessary for the completion of the Work shall be removed from the job site without approval of the Owner.
- 13.12 All Federal, State and local taxes due or payable during the time of Contract on materials, equipment, labor or transportation, in connection with this Work, must be included in the amount bid by the Contractor and shall be paid to proper authorities before acceptance. The Contractor shall furnish all necessary permits and certificates and comply with all laws and ordinances applicable to the locality of the Work. The cost of all inspection fees levied by any governmental entity whatsoever shall be paid for by the Contractor.
- 13.13 In accordance with St. Tammany Police Jury Resolution 86-2672, as amended, the Contractor must provide in a form suitable to the Owner an affidavit stating that all applicable sales taxes for materials used on this project have been paid.
- 13.14 During the period that this Contract is in force, neither party to the Contract shall solicit for employment or employ an employee of the other.
- 13.15 All materials or equipment shown on the Drawings or included in these specifications shall be furnished unless written approval of a substitute is obtained from the Designer, or Owner if no separate designer.
- 13.16 If a potential supplier wishes to submit for prior approval a particular product other than a product specified in the contract documents, he shall do so no later than seven working days prior to the opening of bids. Within three days, exclusive of holidays and weekends, after such submission, the prime design professional shall furnish to both the public entity and the potential supplier written approval or denial of the product submitted. The burden of proof of the equality of the proposed substitute is upon the proposer and only that information formally submitted shall be used by the Designer in making its decision.
- 13.17 The decision of the Designer/Owner shall be given in good faith and shall be final.

#### 14.00 QUANTITIES OF ESTIMATE, CHANGES IN QUANTITIES, EXTRA WORK

- 14.01 Whenever the estimated quantities of Work to be done and materials to be furnished under this Contract are shown in any of the documents, including the Proposal, such are given for use in comparing Bids and the right is especially reserved, except as herein otherwise specifically limited, to increase or diminish same not to exceed twenty-five percent (25%) by the Owner to complete the Work contemplated by this Contract. Such increase or diminution shall in no way vitiate this Contract, nor shall such increase or diminution give cause for claims or liability for damages.
- 14.02 The Owner shall have the right to make alterations in the line, grade, plans, form or dimensions of the Work herein contemplated, provided such alterations do not change the total cost of the Project, based on the originally estimated quantities, and the unit prices bid by more than twenty-five percent (25%) and provided further that such alterations do not change the total cost of any major item, based on the originally estimated quantities and the unit price bid by more than twenty-five (25%). (A major item shall be construed to be any item, the total cost of which is equal to or greater than ten percent (10%) of the total Contract Price, computed on the basis of the Proposal quantity and the Contract unit price). Should it become necessary, for the best interest of the Owner, to make changes in excess of that herein specified, the same shall be covered by supplemental agreement either before or after the commencement of the Work and without notice to the sureties. If such alterations diminish the quantity of Work to be done, such shall not constitute a claim for damages for anticipated profits for the Work dispensed with, but when the reduction in amount is a material part of the Work contemplated, the Contractor shall be entitled to only reasonable compensation as determined by the Owner for overhead and equipment charges which it may have incurred in expectation of the quantity of Work originally estimated, unless specifically otherwise provided herein; if the alterations increase the amount of Work, the increase shall be paid according to the quantity of Work actually done and at the price established for such Work under this Contract except where, in the opinion of the Owner, the Contractor is clearly entitled to extra compensation.
- 14.03 Without invalidating the Contract, the Owner may order Extra Work or make changes by altering, adding to, or deducting from the Work, the Contract sum being adjusted accordingly. The consent of the surety must first be obtained when necessary or desirable, all at the exclusive discretion of the Owner. All the Work of the kind bid upon shall be paid for at the price stipulated in the Proposal, and no claims for any Extra Work or material shall be allowed unless the Work is ordered in writing by the Owner.
- 14.04 Extra Work for which there is no price or quantity included in the Contract shall be paid for at a unit price or lump sum to be agreed upon in advance in writing by the Owner and Contractor. Where such price and sum cannot be agreed upon by both parties, or where this method of payment is impracticable, the Owner may, at its exclusive and unilateral discretion, order the Contractor to do such Work on a Force Account Basis.
- 14.05 In computing the price of Extra Work on a Force Account Basis, the Contractor shall be paid for all foremen and labor actually engaged on the specific Work at the current local rate of wage for each and every hour that said foremen and labor are engaged in such Work, plus ten percent (10%) of the total for superintendence, use of tools, overhead, direct & indirect costs/expenses, pro-rata applicable payroll taxes, pro-rata applicable workman compensation benefits, pro-rata insurance premiums and pro-rata reasonable profit. The Contractor shall furnish satisfactory evidence of the rate or rates of such insurance and tax. The Contractor will not be able to collect any contribution to any retirement plans or programs.
- 14.06 For all material used, the Contractor shall receive the actual cost of such material delivered at the site of the Work, as shown by original receipted bill, to which shall be added five percent (5%). There will be absolutely no additional surcharges or additional fees attached hereto with respect to this subsection.
- 14.07 For any equipment used that is owned by the Contractor, the Contractor shall be allowed a rental based upon the latest prevailing rental price, but not to exceed a rental price as determined by the Associated Equipment Distributors (A.E.D. Green Book).

- 14.08 The Contractor shall also be paid the actual costs of transportation for any equipment which it owns and which it has to transport to the Project for the Extra Work. There will be absolutely no additional surcharges or additional fees attached hereto with respect to this subsection.
- 14.09 If the Contractor is required to rent equipment for Extra Work, but not required for Contract items, it will be paid the actual cost of rental and transportation of such equipment to which no percent shall be added. The basis upon which rental cost are to be charged shall be agreed upon in writing before the Work is started. Actual rental and transportation costs shall be obtained from receipted invoices and freight bills.
- 14.10 No compensation for expenses, fees or costs incurred in executing Extra Work, other than herein specifically mentioned herein above, will be allowed.
- 14.11 A record of Extra Work on Force Account basis shall be submitted to the Owner on the day following the execution of the Work, and no less than three copies of such record shall be made on suitable forms and signed by both the Owner or his representative on the Project and the Contractor. All bids for materials used on extra Work shall be submitted to the Owner by the Contractor upon certified statements to which will be attached original bills covering the costs of such materials.
- 14.12 Payment for Extra Work of any kind will not be allowed unless the same has been ordered in writing by the Owner.

15.00 STATUS OF THE ENGINEER (NOT APPLICABLE)

16.00 INJURIES TO PERSONS AND PROPERTY

- 16.01 The Contractor shall be held solely and exclusively responsible for all injuries to persons and for all damages to the property of the Owner or others caused by or resulting from the negligence of itself, its employees or its agents, during the progress of or in connection with the Work, whether within the limits of the Work or elsewhere under the Contract proper or as Extra Work. This requirement will apply continuously and not be limited to normal working hours or days. The Owner's construction review is for the purpose of checking the Work product produced and does not include review of the methods employed by the Contractor or to the Contractor's compliance with safety measures of any nature whatsoever. The Contractor agrees to pay a reasonable attorney fee and other reasonable attendant costs of the Owner in the event it becomes necessary for the Owner to employ an attorney to enforce this section or to protect itself against suit over the Contractor's responsibilities. Attorney fees shall be at the prevailing hourly rate of the private sector. The attorney fee hourly rate shall not be less than \$175.00 per hour. All attorney fees collected shall be paid to the operating budget of the Office of the Parish President.
- 16.02 The Contractor must protect and support all utility infrastructures or other properties which are liable to be damaged during the execution of its Work. It shall take all reasonable and proper precautions to protect persons, animals and vehicles or the public from the injury, and wherever necessary, shall erect and maintain a fence or railing around any excavation, and place a sufficient number of lights about the Work and keep same burning from twilight until sunrise, and shall employ one or more watchmen as an additional security whenever needed. The Contractor understands and agrees that the Owner may request that security be placed on the premises to ensure and secure same. The Owner shall have exclusive authority to request placement of such security. Contractor agrees to retain and place security as requested, all at the sole expense of Contractor. Additional security shall not be considered a change order or reason for additional payment by the Owner. The Contractor must, as far as practicable and consistent with good construction, permit access to private and public property and leave fire hydrants, catch basins, streets, etc., free from encumbrances. The Contractor must restore at its own expense all injured or damaged property caused by any negligent act of omission or commission on its part or on the part of its employees or subcontractors, including, but not limited to, sidewalks, curbing, sodding, pipes conduits, sewers, buildings, fences, bridges, retaining walls, tanks, power lines, levees or any other building or property whatsoever to a like condition as existed prior to such damage or injury.



- 16.03 In case of failure on the part of the Contractor to restore such property or make good such damage, the Owner may upon forty-eight (48) hours' notice proceed to repair or otherwise restore such property as may be deemed necessary, and the cost thereof will be deducted from any monies due or which may become due under its Contract.
- 16.04 Contractor agrees to protect, defend, indemnify, save, and hold harmless St. Tammany Parish Government, its elected and appointed officials, departments, agencies, boards and commissions, their officers, agents servants, employees, including volunteers, from and against any and all claims, demands, expense and liability arising out of injury or death to any person or the damage, loss or destruction of any property to the extent caused by any negligent act or omission or willful misconduct of Contractor, its agents, servants, employees, and subcontractors, or any and all costs, expense and/or attorney fees incurred by St. Tammany Parish Government as a result of any claim, demands, and/or causes of action that results from the negligent performance or non-performance by Contractor, its agents, servants, employees, and subcontractors of this contract. Contractor agrees to investigate, handle, respond to, provide defense for and defend any such claims, demand, or suit at its sole expense and agrees to bear all other costs and expenses related thereto caused by any negligent act or omission or willful misconduct of Contractor, its agents, servants, employees, and subcontractors.
- 16.05 As to any and all claims against Owner, its agents, assigns, representatives or employees by any employee of Contractor, any Subcontractor, anyone directly or indirectly employed by any of them or anyone for whose acts as may be liable, the indemnification obligation under Paragraph 16.04 shall not be limited in any way or by any limitation on the amount or type of damages, compensation or benefits payable by or for Contractor or any Subcontractor under workmen's compensation acts, disability benefit acts or other employee benefit acts.
- 16.06 No road shall be closed by the Contractor to the public except by written permission of the Owner. If so closed, the Contractor shall maintain traffic over, through and around the Work included in his Contract, with the maximum practical convenience, for the full twenty-four hours of each day of the Contract, whether or not Work has ceased temporarily. The Contractor shall notify the Owner at the earliest possible date after the Contract has been executed and, in any case, before commencement of any construction that might in any way inconvenience or endanger traffic, in order that necessary and suitable arrangements may be determined. Any and all security, maintenance, labor or costs associated with traffic control herein shall be at the sole expense of Contractor. This expense shall be paid directly by the Contractor. This expense shall not be considered as a change order nor shall it allow the Contractor any additional cost reimbursement whatsoever. All traffic deviations herein shall be coordinated with the appropriate law enforcement officials of this Parish.
- 16.07 The convenience of the general public and residents along the Works shall be provided for in a reasonable, adequate and satisfactory manner. Where existing roads are not available as detours, and unless otherwise provided, all traffic shall be permitted to pass through the Work. In all such cases, the public shall have precedence over Contractor's vehicles insofar as the traveling public's vehicles shall not be unduly delayed for the convenience of the Contractor. In order that all unnecessary delay to the traveling public may be avoided, the Contractor shall provide and station competent flagmen whose sole duties shall consist of directing and controlling the movement of public traffic either through or around the Work. Any and all security, maintenance, labor or costs associated with traffic control herein shall be at the sole expense of Contractor. This expense shall be paid directly by the Contractor. This expense shall not be considered as a change order nor shall it allow the Contractor any additional cost reimbursement whatsoever. All traffic deviations herein shall be coordinated with the appropriate law enforcement officials of this Parish.
- 16.08 The Contractor shall arrange its Work so that no undue or prolonged blocking of business establishments will occur.
- 16.09 Material and equipment stored on the right of way or work site shall be so placed and the Work at times shall be so conducted as to ensure minimum danger and obstruction to the traveling public.
- 16.10 During grading operations when traffic is being permitted to pass through construction, the Contractor shall provide a smooth, even surface that will provide a satisfactory passageway

for use of traffic. The road bed shall be sprinkled with water if necessary to prevent a dust nuisance, provided the dust nuisance is a result of the Work.

- 16.11 Fire hydrants shall be accessible at all times to the Fire Department. No material or other obstructions shall be placed closer to a fire hydrant than permitted by ordinances, rules or regulations or within fifteen (15) feet of a fire hydrant, in the absence of such ordinance, rules or regulations.
- 16.12 The Contractor shall not, without the written permission of the Owner, do Work for a resident or property owner abutting the Work at the time that this Work is in progress.
- 16.13 No Work of any character shall be commenced on railroad right-of-way until the Railroad Company has issued a permit to the Owner and has been duly notified by the Contractor in writing (with a copy forwarded to the Owner) of the date it proposes to begin Work, and until an authorized representative of the Railroad Company is present, unless the Railroad Company waives such requirements. All Work performed by the Contractor within the right-of-way limits of the railroad shall be subject to the inspection and approval of the chief engineer of the Railroad Company or its authorized representative. Any precautions considered necessary by said chief engineer to safeguard the property, equipment, employees and passengers of the Railroad Company shall be taken by the Contractor without extra compensation. The Contractor shall, without extra compensation, take such precautions and erect and maintain such tell-tale or warning devices as the Railroad Company considers necessary to safeguard the operation of its trains. The temporary vertical and horizontal clearance specified by the chief engineer of the Railroad Company in approving these shall be maintained at all times. No steel, brick, pipe or any loose material shall be left on the ground in the immediate vicinity of the railway track. Before any Work is done within Railroad right of way, the Contractor shall provide and pay all costs of any special insurance requirements of the Railroad.
- 16.14 The Contractor, shall, without extra compensation, provide, erect, paint and maintain all necessary barricades. Also, without extra compensation, the Contractor shall provide suitable and sufficient lights, torches, reflectors or other warning or danger signals and signs, provide a sufficient number of watchmen and flagmen and take all the necessary precautions for the protection of the Work and safety of the Public.
- 16.15 The Contractor shall erect warning signs beyond the limits of the Project, in advance of any place on the Project where operations interfere with the use of the road by traffic, including all intermediate points where the new Work crosses or coincides with the existing road. All barricades and obstructions shall be kept well painted and suitable warning signs shall be placed thereon. All barricades and obstructions shall be illuminated at night and all lights or devices for this purpose shall be kept burning from sunset to sunrise.
- 16.16 Whenever traffic is maintained through or over any part of the Project, the Contractor shall clearly mark all traffic hazards. No direct payment will be made for barricades, signs and illumination therefore or for watchmen or flagmen.
- 16.17 The Contractor will be solely and completely responsible for conditions on the job site, including safety of all persons and property during performance of the Work. This requirement will apply continuously and not be limited to normal working hours. The duty of the Owner to conduct construction review of the Contractor's performance is not intended to include review of the adequacy of the Contractor's safety measures, in, or near the construction site.

#### 17.00 SANITARY PROVISIONS

- 17.01 The Contractor shall provide and maintain in a neat, sanitary condition such accommodations for the use of its employees as may be necessary to comply with the rules and regulations of the State Health Agency or of the other authorities having jurisdiction and shall permit no public nuisance.

#### 18.00 RIGHTS OF WAY

18.01 The Owner will furnish the Contractor with all necessary rights-of-way for the prosecution of the Work. The rights of way herein referred to shall be taken to mean only permission to use or pass through the locations or space in any street, highway, public or private property in which the Contractor is to prosecute the Work.

18.02 It is possible that all lands and rights of way may not be obtained as herein contemplated before construction begins, in which event the Contractor shall begin its Work upon such land and rights of way as the Owner may have previously acquired. Any delay in furnishing these lands by the Owner can be deemed proper cause for adjustment in the Contract amount and/or in the time of completion.

#### 19.00 PROTECTION AND RESTORATION OF PROPERTY AND LANDSCAPE

19.01 The Contractor shall not enter upon private property for any purpose without first obtaining permission from the Owner, as well as the private property owner and/or and private property Lessees. The Contractor shall use every precaution necessary for the preservation of all public and private property, monuments, highway signs, telephone lines, other utilities, etc., along and adjacent to the Work; the Contractor shall use every precaution necessary to prevent damage to pipes, conduits, and other underground structures; and shall protect carefully from disturbance or damage all land monuments and property marks until an authorized agent has witnessed or otherwise referenced their location and shall not remove them until directed. The street and highway signs and markers that are to be affected by the Work shall be carefully removed when the Work begins and stored in a manner to keep them clean and dry. The Contractor must obtain all necessary information in regard to existing utilities and shall give notice in writing to the owners or the proper authorities in charge of streets, gas, water, pipes, electric, sewers and other underground structures, including conduits, railways, poles and pole lines, manholes, catch basins, fixtures, appurtenances, and all other property that may be affected by the Contractor's operations, at least forty-eight (48) hours before its operations will affect such property. The Contractor shall not hinder or interfere with any person in the protection of such Work or with the operation of utilities at any time. When property, the operation of railways, or other public utilities are endangered, the Contractor shall at its own expense, maintain flagmen or watchmen and any other necessary precautions to avoid interruption of service or damage to life or property, and it shall promptly repair, restore, or make good any injury or damage caused by its negligent operations in an acceptable manner. The Contractor must also obtain all necessary information in regard to the installation of new cables, conduits, and transformers, and make proper provisions and give proper notifications, in order that same can be installed at the proper time without delay to the Contractor or unnecessary inconvenience to the Owner.

19.02 The Contractor shall not remove, cut or destroy trees, shrubs, plants, or grass that are to remain in the streets or those which are privately owned, without the proper authority. Unless otherwise provided in the Special Provisions or the Proposal, the Contractor shall replace and replant all plants, shrubs, grass and restore the grounds back to its original good condition to the satisfaction of the Owner and/or the property owner. The Contractor shall assume the responsibility of replanting and guarantees that plants, shrubs, grass will be watered, fertilized and cultivated until they are in a growing condition. No direct payment will be made for removing and replanting of trees, shrubs, plants or grass unless such items are set forth in the Proposal.

19.03 When or where direct damage or injury is done to public or private property by or on account of any negligent act, omission, neglect or otherwise of the Contractor, it shall make good such damage or injury in an acceptable manner.

#### 20.00 CONTRACTORS RESPONSIBILITY FOR WORK

20.01 Until final acceptance of the Work by the Owner as evidence by approval of the final estimate, the Work shall be in the custody and under the charge and care of the Contractor and it shall take every necessary precaution against injury or damage to any part thereof by the action of the elements or from the non-execution of the Work; unless otherwise provided for elsewhere in the Specifications or Contract. The Contractor shall rebuild, repair, restore and make good, without extra compensation, all injuries or damages to any portion of the Work occasioned by any of the above causes before its completion and

acceptance, and shall bear the expenses thereof. In case of suspension of the Work from any cause whatever, the Contractor shall be responsible for all materials and shall properly and securely store same, and if necessary, shall provide suitable shelter from damage and shall erect temporary structures where necessary. If in the exclusive discretion of the Owner, any Work or materials shall have been damaged or injured by reason of failure on the part of the Contractor or any of its Subcontractors to so protect the Work, such materials shall be removed and replaced at the sole expense of the Contractor. Such amount shall be deducted from any sum due or to be due Contractor.

20.02 The Contractor shall give all notice and comply with all Federal, State, and local laws, ordinances, and regulations in any manner affecting the conduct of the Work, and all such orders and decrees as exist, or may be enacted by bodies or tribunals having any jurisdiction or authority over the Work, and shall indemnify and hold harmless the Owner against any claim or liability arising from, or based on, the violation of any such law, ordinance, regulation, order or decree, whether by itself, its employees or Subcontractors.

#### 21.00 TESTS AND INSPECTIONS CORRECTION & REMOVAL OF DEFECTIVE WORK

21.01 Contractor warrants and guarantees to Owner that all materials and equipment will be new unless otherwise specified and that all Work will be of good quality and free from faults or defects and in accordance with the requirements of the Contract Documents. All unsatisfactory Work, all faulty or Defective Work and all Work not conforming to the requirements of the Contract Documents at the time of acceptance shall be considered Defective. Prompt and reasonable notice of all defects shall be given to the Contractor.

21.02 If the Contract Documents, laws, ordinances, rules, regulations or orders of any public authority having jurisdiction require any Work to specifically be inspected, tested or approved by some public body, Contractor shall assume full responsibility therefor, pay all costs in connection therewith and furnish Owner the required certificates of inspection, testing or approval. All other inspections, tests and approval required by the Contract Documents shall be performed by organizations acceptable to Owner and Contractor and the costs thereof shall be borne by the Contractor unless otherwise specified.

21.03 Contractor shall give Owner timely notice of readiness of the Work for all inspections, tests or approvals. If any such Work required to be inspected, tested or approved is covered without written approval of Owner, it must, if requested by Owner, be uncovered for observation, and such uncovering shall be at Contractor's expense unless Contractor has given Owner timely notice of its intention to cover such Work and Owner has not acted with reasonable promptness in response to such notice.

21.04 Neither observations by Owner nor inspections, tests or approvals shall relieve Contractor from its obligations to perform the Work in accordance with the requirements of the Contract Document.

21.05 Owner and its representatives will at reasonable times have access to the Work. Contractor shall provide proper and safe facilities for such access and observation of the Work and also for any inspection or testing thereof by others.

21.06 If any Work is covered contrary to the written request of Owner, it must, be uncovered for Owner's observation and replaced at Contractor's expense. If any Work has been covered which Owner has not specifically requested to observe prior to its being covered, or if Owner considers it necessary or advisable that covered Work be inspected or tested by others, the Contractor, at Owner's request, shall uncover, expose or otherwise make available for observations, inspections or testing as Owner may require, that portion of the Work in question, furnishing all necessary labor, material and equipment. If it is found that such Work is Defective, Contractor shall bear all the expenses of such uncovering, exposure, observation, inspection and testing and of satisfactory reconstruction, including compensation for additional professional services, and an appropriate deductive Change Order shall be issued. If, however, such Work is not found to be Defective, Contractor shall be allowed an increase in the Contract Price or an extension of the Contract Time, or both, directly attributable to such uncovering, exposure, observation, inspection, testing and reconstruction.

- 21.07 If the Work is Defective, or Contractor fails to supply sufficient skilled workmen or suitable materials or equipment, or if the Contractor fails to make prompt payments to Subcontractors or for labor, materials or equipment, Owner may order Contractor to stop the Work, or any portion thereof, until the cause of such order has been eliminated; however, this right of Owner to stop the Work shall not give rise to any duty on the part of Owner to exercise this right for the benefit of Contractor or any other party.
- 21.08 Prior to approval of final payment, Contractor shall promptly, without cost to Owner and as specified by Owner, either correct any Defective Work, whether or not fabricated, installed or completed, or if the Work has been rejected by Owner, remove it from the site and replace it with non-defective Work. If Contractor does not correct such Defective Work or remove and replace such rejected Work within a reasonable time, all as specified in a written notice from Owner, Owner may have the deficiency corrected or the rejected Work removed and replaced. All direct or indirect costs of such correction or removal and replacement including compensation for additional professional services shall be paid by Contractor, and an appropriate deductive Change Order shall be issued. Contractor shall also bear the expense of making good all Work of others destroyed or damaged by its correction, removal or replacement of its Defective Work.
- 21.09 If, after the approval of final payment and prior to the expiration of one year after the date of Substantial Completion or such longer period of time as may be prescribed by law or by the terms of any applicable special guarantee required by the Contract Documents, any Work is found to be Defective, Contractor shall promptly, without cost to Owner and in accordance with Owner's written instructions, either correct such Defective Work or if it has been rejected by Owner, remove it from the site and replace it with non-defective Work. If Contractor does not promptly comply with the terms of such instructions, Owner may have the Defective Work corrected or the rejected Work removed and replaced, and all direct and indirect costs of such removal and replacement, including compensation for additional professional services, shall be paid by Contractor. The Contractor agrees to pay a reasonable attorney fee and other reasonable attendant costs of the Owner in the event it becomes necessary for the Owner to employ an attorney to enforce this section or to protect itself against suit over the Contractor's responsibilities. Attorney fees shall be at the prevailing hourly rate of the private sector. The attorney fee hourly rate shall not be less than \$175.00 per hour. All attorney fees collected shall be paid to the operating budget of the Office of the Parish President.
- 21.10 If, instead of requiring correction or removal and replacement of Defective Work, Owner (and prior to approval of final payment) prefers to accept it, the Owner may do so. In such case, if acceptance occurs prior to approval of final payment, a Change Order shall be issued incorporating the necessary revisions in the Contract Documents, including appropriate reduction in the Contract Price, or, if the acceptance occurs after approval of final payment, an appropriate amount shall be paid by Contractor to Owner.
- 21.11 If Contractor should fail to progress the Work in accordance with the Contract Documents, including any requirements of the Progress Schedule, Owner, after seven (7) days written Notice to Contractor, may, without prejudice to any other remedy Owner may have, make good such deficiencies and the cost thereof including compensation for additional professional services shall be charged against Contractor. In such cases, a Change Order shall be issued incorporating the necessary revisions in the Contract Documents including an appropriate reduction in the Contract Price. If the payments then or thereafter due Contractor are not sufficient to cover such amount, Contractor shall pay the difference to Owner.
- 21.12 The Owner may appoint representatives to make periodic visits to the site and observe the progress and quality of the executed Work. These representatives shall be governed by the same restrictions placed on the Owner by these Specifications. The governing body of the Federal, State or local government exercising authority in the area of the Work may appoint representatives to observe the progress and quality of the Work. Contractor shall cooperate with and assist these representatives in the performance of their duties.
- 21.13 The Contractor shall be responsible for the faithful execution of its Contract and the presence or absence of the Owner's or Government's Representative is in no way or manner to be presumed or assumed to relieve in any degree the responsibility or obligation of the Contractor.

- 21.14 The Contractor shall notify the Owner and the Governmental Agency having jurisdiction as to the exact time at which it is proposed to begin Work so the Owner may provide for inspection of all materials, foundations, excavations, equipment, etc., and all or any part of the Work and to the preparation or manufacture of materials to be used whether within the limits of the Work or at any other place.
- 21.15 The Owner or its representatives shall have free access to all parts of the Work and to all places where any part of the materials to be used are procured, manufactured or prepared. The Contractor shall furnish the Owner all information relating to the Work and the material therefor, which may be deemed necessary or pertinent, and with such samples of materials as may be required. The Contractor, at its own expense, shall supply such labor and assistance as may be necessary in the handling of materials for proper inspection or for inspection of any Work done by it.
- 21.16 No verbal instructions given to the Contractor by the Owner, Project Representative or any of their agents shall change or modify the written Contract. Contractors shall make no claims for additional payments or time based upon verbal instructions.

## 22.00 SUBSURFACE CONDITIONS

- 22.01 It is understood and agreed that the Contractor is familiar with the subsurface conditions that will be encountered and its price bid for the Work includes all of the costs involved for Work in these conditions and it is furthermore agreed that it has taken into consideration, prior to its Bid and acceptance by Owner, all of the subsurface conditions normal or unusual that might be encountered in the location of the Work.
- 22.02 Should the Contractor encounter during the progress of the Work subsurface conditions at the site materially differing from those shown on the Drawings or indicated in the Specifications, the attention of the Owner shall be directed to such conditions before the conditions are disturbed. If the Owner finds that the conditions materially differ from those shown on the Drawings or indicated in the Specifications, it shall at once make such changes in the Drawings or Specifications as it may find necessary, and any increase or decrease in cost or extension of time resulting from such changes shall be adjusted in the same manner as provided for changes for Extra Work. The Contractor shall submit breakdowns of all costs in a manner as instructed and approved by the Owner.

## 23.00 REMOVAL AND DISPOSAL OF STRUCTURES AND OBSTRUCTIONS

- 23.01 Bidder shall thoroughly examine the site of the Work and shall include in its Bid the cost of removing all structures and obstructions in the way of the Work.
- 23.02 The Contractor shall remove any existing structures or part of structures, fence, building or other encumbrances or obstructions that interfere in any way with the Work. Compensations for the removal of any structure shall be made only if the item(s) to be removed was/were listed as pay item(s) on the Proposal.
- 23.03 If called for in the Special Conditions, all privately and publicly owned materials and structures removed shall be salvaged without damage and shall be piled neatly and in an acceptable manner upon the premises if it belongs to an abutting property owner, otherwise at accessible points along the improvements. Materials in structures which is the property of the Owner or property of any public body, private body or individual which is fit for use elsewhere, shall remain property of the original Owner. It shall be carefully removed without damage, in sections which may be readily transported; same shall be stored on or beyond the right of way. The Contractor will be held responsible for the care and preservation for a period of ten (10) days following the day the last or final portion of the materials stored at a particular location are placed thereon. When privately owned materials are stored beyond the right of way, the Contractor will be held responsible for such care and preservation for a period of ten (10) days responsibility period for care and preservation of the materials begins. The Contractor must furnish the Owner with evidence satisfactory that the proper owner of the materials has been duly notified by the Contractor that the said owner must assume responsibility for its materials on the date following the Contractor's ten (10) day responsibility.

## 24.00 INSURANCE

- 24.01 Contractor shall secure and maintain at its expense such insurance that will protect it and the Parish from claims for injuries to persons or damages to property which may arise from or in connection with the performance of Services or Work hereunder by the Contractor, his agents, representatives, employees, and/or subcontractors. The cost of such insurance shall be included in Contractor's bid.
- 24.02 The Contractor shall not commence work until it has obtained all insurance as required for the Parish Project. If the Contractor fails to furnish the Parish with the insurance protection required and begins work without first furnishing Parish with a currently dated certificate of insurance, the Parish has the right to obtain the insurance protection required and deduct the cost of insurance from the first payment due the Contractor. Further deductions are permitted from future payments as are needed to protect the interests of the Parish including, but not limited to, renewals of all policies.
- 24.03 Payment of Premiums: The insurance companies issuing the policy or policies shall have no recourse against the Parish of St. Tammany for payment of any premiums or for assessments under any form of policy.
- 24.04 Deductibles: Any and all deductibles in the described insurance policies shall be assumed by and be at the sole risk of the Contractor.
- 24.05 Authorization of Insurance Company(ies) and Rating: All insurance companies must be authorized to do business in the State of Louisiana and shall have an A.M. Best rating of no less than A-, Category VII.
- 24.06 Policy coverages and limits must be evidenced by Certificates of Insurance issued by Contractor's carrier to the Parish and shall reflect:

Date of Issue: Certificate must have current date.

Named Insured: The legal name of Contractor under contract with the Parish and its principal place of business shall be shown as the named insured on all Certificates of Liability Insurance.

Name of Certificate Holder: St. Tammany Parish Government, Office of Risk Management, P. O. Box 628, Covington, LA 70434

Project Description: A brief project description, including Project Name, Project Number and/or Contract Number, and Location.

Endorsements and Certificate Reference: All policies must be endorsed to provide, and certificates of insurance must evidence the following:

Waiver of Subrogation: The Contractor's insurers will have no right of recovery or subrogation against the Parish of St. Tammany, it being the intention of the parties that all insurance policy(ies) so affected shall protect both parties and be the primary coverage for any and all losses covered by the below described insurance. *Policy endorsements required for all coverages.*

Additional Insured: The Parish of St. Tammany shall be named as additional named insured with respect to general liability, marine liability, pollution/environmental liability, automobile liability and excess liability coverages. *Policy endorsements required.*

Hold Harmless: Contractor's liability insurers shall evidence their cognizance of the Hold Harmless and Indemnification in favor of St. Tammany Parish Government by referencing same on the face of the Certificate(s) of Insurance.

Cancellation Notice: Producer shall provide thirty (30) days prior written notice to the Parish of policy cancellation or substantive policy change.

24.07 The types of insurance coverage the Contractor is required to obtain and maintain throughout the duration of the Contract, include, but is not limited to:

1. Commercial General Liability insurance with a Combined Single Limit for bodily injury and property damage of at least \$1,000,000 per Occurrence/\$3,000,000 General Aggregate/Products-Completed Operations Per Project. The insurance shall provide for and the certificate(s) of insurance shall indicate the following coverages:
  - a) Premises - operations;
  - b) Broad form contractual liability;
  - c) Products and completed operations;
  - d) Personal Injury;
  - e) Broad form property damage;
  - f) Explosion and collapse.
2. Marine Liability/Protection and Indemnity insurance is required for any and all vessel and/or marine operations in the minimum limits of \$1,000,000 per occurrence/\$2,000,000 per project general aggregate. The coverage shall include, but is not limited to, the basic coverages found in the Commercial General Liability insurance and coverage for third party liability.
3. Contractors' Pollution Liability and Environmental Liability insurance in the minimum amount of \$1,000,000 per occurrence, \$2,000,000 general aggregate and include coverage for full contractual liability and for all such environmental and/or hazardous waste exposures affected by this project.
4. Business Automobile Liability insurance with a Combined Single Limit of \$1,000,000 per Occurrence for bodily injury and property damage, and shall include coverage for the following:
  - a) Any automobiles;
  - b) Owned automobiles;
  - c) Hired automobiles;
  - d) Non-owned automobiles;
  - e) Uninsured motorist.
5. Workers' Compensation/Employers Liability insurance: worker's compensation insurance coverage and limits as statutorily required; Employers' Liability Coverage shall be not less than \$1,000,000 each accident, \$1,000,000 each disease, \$1,000,000 disease policy aggregate, except when projects include exposures covered under the United States Longshoremen and Harbor Workers Act, Maritime and/or Jones Act and/or Maritime Employers Liability (MEL) limits shall be not less than \$1,000,000/\$1,000,000/\$1,000,000. *Coverage for owners, officers and/or partners shall be included in the policy and a statement of such shall be made by the insuring producer on the face of the certificate.*
6. Owners Protective Liability (OPL) (formerly Owners and Contractors Protective Liability (OCP) Insurance) shall be furnished by the Contractor naming St. Tammany Parish Government as the Named Insured and shall provide coverage in the minimum amount of \$1,000,000 combined single limit (CSL) each occurrence, \$2,000,000 aggregate. Any project valued in excess of \$3,000,000 shall be set by the Office of Risk Management. The policy and all endorsements shall be addressed to St. Tammany Parish Government, Office of Risk Management, P. O. Box 628, Covington, LA 70434.
7. Builder's Risk Insurance shall be required on buildings, sewage treatment plants and drainage pumping stations, and shall be written on an "all-risk" or equivalent policy form in the amount of the full value of the initial Contract sum, plus value of subsequent Contract modifications and cost of materials supplied or installed by others, comprising 100% total value for the entire project including foundations. Deductibles should not exceed \$5,000 and Contractor shall be responsible for any and all policy deductibles. This insurance shall cover portions of the work stored off the site, and also portions of the work in transit. In addition, Installation Floater



Insurance, on an “all-risk” form, will be carried on all pumps, motors, machinery and equipment on the site or installed. Both the Builder’s Risk Insurance and the Installation Floater Insurance shall include the interests of the Owner, Contractor, Subcontractors, and Sub-subcontractors and shall terminate only when the Project has been accepted. St. Tammany Parish Government, P. O. Box 628, Covington, LA 70434 shall be the first named insured on the Builder’s Risk and Installation Floater Insurance.

8. Professional Liability (errors and omissions) insurance in the sum of at least One Million Dollars (\$1,000,000) per claim with Two Million Dollars (\$2,000,000) annual aggregate.
  9. An umbrella policy or excess policy may be required and/or allowed to meet minimum coverage limits, subject to the review and approval by St. Tammany Parish Government, Office of Risk Management.
- 24.08 All policies of insurance shall meet the requirements of the Parish of St. Tammany prior to the commencing of any work. The Parish of St. Tammany has the right, but not the duty, to approve all insurance policies prior to commencing of any work. If at any time, it becomes known that any of the said policies shall be or becomes unsatisfactory to the Parish of St. Tammany as to form or substance; or if a company issuing any such policy shall be or become unsatisfactory to the Parish of St. Tammany, the Contractor shall promptly obtain a new policy, timely submit same to the Parish of St. Tammany for approval and submit a certificate thereof as provided above. The Parish agrees to not unreasonably withhold approval of any insurance carrier selected by Contractor. In the event that Parish cannot agree or otherwise authorize said carrier, Contractor shall have the option of selecting and submitting new insurance carrier within 30 days of said notice by the Parish. In the event that the second submission is insufficient or is not approved, then the Parish shall have the unilateral opportunity to thereafter select a responsive and responsible insurance carrier all at the cost of Contractor and thereafter deduct from Contractor's fee the cost of such insurance.
- 24.09 Upon failure of Contractor to furnish, deliver and/or maintain such insurance as above provided, the contract, at the election of the Parish of St. Tammany, may be forthwith declared suspended, discontinued or terminated. Failure of the Contractor to maintain insurance shall not relieve the Contractor from any liability under the contract, nor shall the insurance requirements be construed to conflict with the obligation of the Contractor concerning indemnification.
- 24.10 Contractor shall maintain a current copy of all annual insurance policies and provide same to the Parish of St. Tammany as may be reasonably requested.
- 24.11 It shall be the responsibility of Contractor to require that these insurance requirements are met by all contractors and sub-contractors performing work for and on behalf of Contractor. Contractor shall further ensure the Parish is named as additional insured on all insurance policies provided by said contractor and/or sub-contractor throughout the duration of the project, and that renewal certificates for any policies expiring prior to the Parish’s final acceptance of the project shall be furnished to St. Tammany Parish Government, Department of Legal, Office of Risk Management, without prompting.

**NOTICE:**

*These are only an indication of the coverages that are generally required. Additional coverages and/or limits may be required for projects identified as having additional risks or exposures. Please note that some requirements listed may not necessarily apply to your specific services. St. Tammany Parish Government reserves the right to remove, replace, make additions to and/or modify any and all of the insurance requirement language upon review of the final scope of services presented to Office of Risk Management prior to execution of a contract for services.*

**For inquiries regarding insurance requirements, please contact:**

**St. Tammany Parish Government  
Office of Risk Management  
P. O. Box 628  
Covington, LA 70434  
Telephone: 985-898-5226  
Email: [riskman@stpgov.org](mailto:riskman@stpgov.org)**

24.12 Nothing contained in these insurance requirements is to be construed as limiting the extent of the Contractor's Responsibility for payment of damages resulting from its operations under this Contract.

25.00 OWNER'S RIGHT TO OCCUPANCY

25.01 The Owner shall have the right to use, at any time, any and all portions of the Work that have reached such a stage of completion as to permit such occupancy, provided such occupancy does not hamper the Contractor or prevent its efficient completion of the Contract or be construed as constituting an acceptance of any part of the Work.

25.02 The Owner shall have the right to start the construction of houses, structures or any other building concurrent with the Contractor's Work.

26.00 SURVEY HORIZONTAL AND VERTICAL CONTROL

26.01 The Owner shall provide surveys for construction to establish reference points which in its judgment are necessary to enable Contractor to layout and proceed with its Work. Contractor shall be responsible for surveying and laying out the Work and shall protect and preserve the established reference points and shall make no changes or relocations without the prior written approval of the Owner. Contractor shall report to Owner whenever any reference point is lost or destroyed and the Owner shall decide if the reference point shall be replaced by its or the Contractor's forces.

26.02 The Contractor shall establish lines and grades with its own forces in sufficient number and location for the proper execution of the Work.

26.03 If the Contractor, during the construction, damages the established property corners and/or other markers and thereafter requests the Owner to re-stake same in order to complete the project, this expense will be borne solely by the Contractor.

27.00 TERMINATION OF THE CONTRACT, OWNER'S AND CONTRACTORS RIGHT TO STOP WORK.

27.01 If the Contractor should be adjudged bankrupt (voluntarily or involuntarily) or if it should make a general assignment for the benefit of its creditors, or if a receiver should be appointed on account of its insolvency, or if it should persistently or repeatedly refuse or should fail (except in cases for which extension of time is provided) to supply enough properly skilled workmen or proper materials, or if it should fail to make prompt payment to Subcontractors or for material or labor, or persistently disregard laws, ordinances or the instructions of the Owner, or otherwise be guilty of a substantial violation of any provision

of the Contract, then the Owner, upon the certificate of the Owner that, in its unilateral discretion and judgment, believes sufficient cause exists to justify such action, may, without prejudice to any other right or remedy and after giving the Contractor ten (10) calendar days written notice, terminate the employment of the Contractor and take possession of the premises and of all materials, tools and appliances thereon and finish the Work by whatever method the Owner may deem expedient.

- 27.02 Failure of the Contractor to start the Work within the time limit specified herein or substantial evidence that the progress being made by the Contractor is sufficient to complete the Work within the specified time shall be grounds for termination of the Contract by the Owner.
- 27.03 Before the Contract is terminated, the Contractor and its surety will first be notified in writing by the Owner of the conditions which make termination of the Contract imminent. When after ten (10) calendar days' notice is given and if satisfactory effort has not been made by the Contractor or its surety to correct the conditions, the Owner may declare, in its exclusive discretion, that the Contract is terminated and so notify the Contractor and its surety accordingly.
- 27.04 Upon receipt of notice from the Owner that the Contract has been terminated, the Contractor shall immediately discontinue all operations. The Owner may then proceed with the Work in any lawful manner that it may elect until Work is finally completed.
- 27.05 The exclusive right is reserved to the Owner to take possession of any machinery, implements, tools or materials of any description that shall be found upon the Work, to account for said equipment and materials, and to use same to complete the Project. When the Work is finally completed, the total cost of same will be computed. If the total cost is less than the Contract Price, the difference will not be paid to the Contractor or its surety.
- 27.06 In case of termination, all expenses incident to ascertaining and collecting losses under the Bond, including legal services, shall be assessed against the Bond.
- 27.07 If the Work should be stopped under any order of any court or public authority for period of sixty (60) calendar days, through no act or fault of the Contractor or anyone employed by it, or if the Owner shall fail to pay the Contractor within a reasonable time any sum certified by the Owner, then the Contractor may, upon ten (10) calendar days written notice to the Owner, stop Work or terminate this Contract and recover from the Owner payment for all Work properly and professionally executed in a workmanlike manner. This loss specifically includes actual cost of materials and equipment, together with all wages inclusive of all federal, state, and local tax obligations. This loss specifically includes reimbursement of all insurances on a pro-rata basis from the date of termination to date of policy period. This loss excludes and specifically does not include recovery by the Contractor for lost profit, indirect & direct expenses, overhead, and the like.

## 28.00 PAYMENTS TO THE CONTRACTOR

- 28.01 Monthly certificates for partial payment, in a form approved by the Owner, shall be transmitted to the Owner upon receipt from the Contractor and acceptance by the Owner. In accordance with LSA-R.S. 38:2248(A), when the Contract Price is less than five hundred thousand dollars, these certificates shall be equal to ninety percent (90%) of both the Work performed and materials stored at the site; and when the Contract Price is five hundred thousand dollars or more, these certificates shall be equal to ninety-five percent (95%) of both the Work performed and materials stored at the site. Partial payment certificates shall include only Work, materials and equipment that are included in official Work Order and which meet the requirements of plans, Specifications and Contract Documents. These monthly estimates shall show the amount of the original estimate for each item, the amount due on each item, the gross total, the retained percentage, the amount previously paid and the net amount of payment due.
- 28.02 After final completion and acceptance by the Owner of the entire Work, and when the Contract Price is less than five hundred thousand dollars, the Owner shall issue to the Contractor Certificate of Payment in sum sufficient to increase total payments to ninety percent (90%) of the Contract Price. After final completion and acceptance by the Owner of the entire Work, and when the Contract Price is five hundred thousand dollars or more,

the Owner shall issue to the Contractor Certificate of Payment in sum sufficient to increase total payments to ninety-five percent (95%) of the Contract Price.

- 28.03 When the Contract Price is less than five hundred thousand dollars, the final payment certificate of the remaining ten percent (10%) of the Contract Price, minus any deduction for deficient or Defective Work or other applicable deductions, will be issued by the Owner forty-five (45) days after filing acceptance in the Mortgage Office of the Parish and a Clear Liens and Privilege Certificate has been secured. When the Contract Price is five hundred thousand dollars or more, the final payment certificate of the remaining five percent (5%) of the Contract Price, minus any deduction for deficient or Defective Work or other applicable deductions, will be issued by the Owner forty-five (45) days after filing acceptance in the Mortgage Office of the Parish and a Clear Liens and Privilege Certificate has been secured. Before issuance of the final payment certificate, the Contractor shall deposit with the Owner a certificate from the Clerk of Court and Ex-Officio Recorder of Mortgages from the Parish in which the Work is performed to the effect that no liens have been registered against Contract Work.
- 28.04 When, in the opinion of the Contractor, the Work provided for and contemplated by the Contract Documents has been substantially completed, the Contractor shall notify the Owner in writing that the Work is substantially complete and request a final inspection. The Owner shall proceed to perform such final inspection accompanied by the Contractor. Any and all Work found by this inspection to be Defective or otherwise not in accordance with the plans and Specifications shall be corrected to the entire satisfaction of the Owner and at the sole expense of the Contractor. If the Contract is found to be incomplete in any of its details, the Contractor shall at once remedy such defects, and payments shall be withheld and formal acceptance delayed until such Work has been satisfactorily completed.
- 28.05 If payment is requested on the basis of materials and equipment not incorporated in the Work, but delivered and suitably stored and protected from damage and theft at the site, the Request for Payment shall also be accompanied by such data, satisfactory to the Owner, as will establish Owner's title to the material and equipment and protect its interest therein, including applicable insurance.
- 28.06 Each subsequent Request for Payment shall include an affidavit of Contractor stating that all previous progress payments received on account of the Work have been applied to discharge in full all of Contractor's obligations reflected in prior Request for Payment.
- 28.07 Each subsequent request for payment shall include an affidavit by Contractor that Contractor, all subcontractors, agents, material suppliers and all other persons supplying material to the project upon which State of Louisiana and/or St. Tammany sales taxes are lawfully due have paid these taxes and that all supplies and materials purchased for this project and for which Contractor has been paid have had all lawfully due State and/or St. Tammany sales taxes paid.
- 28.08 The Bid Proposal, unless otherwise modified in writing, and the Contract constitute the complete Project. The Contract Prices constitute the total compensation payable to Contractor and the cost of all of the Work and materials, taxes, permits and incidentals must be included into the Bid submitted by the Contractor and included into those items listed on the Proposal.
- 28.09 Any additional supporting data required by the Owner in order to substantiate Contractor's request for payment shall be furnished by Contractor at no cost to the Owner.
- 28.10 Owner may withhold from payment to Contractor as may be necessary to protect itself from loss on account of:
- (1) Defective and/or inferior work;
  - (2) Damage to the property of Owner or others caused by Contractor;
  - (3) Failure by Contractor to make payments properly to sub-contractors or to pay for labor, materials or equipment used on this project;
  - (4) Failure by Contractor to pay taxes due on materials used on this project;
  - (5) Damage by Contractor to another Contractor;
  - (6) Insolvency;
  - (7) Bankruptcy, voluntary or involuntary;
  - (8) Revocation of corporate status;

- (9) Failure to follow corporate formalities;
- (10) Unprofessional activities;
- (11) Unworkmanlike performance;
- (12) Fraud and/or misrepresentation of any kind.

29.00 ACCEPTANCE AND FINAL PAYMENT(S)

- 29.01 Upon receipt of written notice from Contractor that the work is substantially complete and usable by Owner or the Public in suitable manner, the Owner and the Contractor shall jointly inspect the work.
- 29.02 If the Owner by inspection determines that the work is not substantially complete in a suitable manner for use by the Owner or the Public, then the Owner shall so notify the Contractor in writing stating such reason. All reasons need not be disclosed unless actually known. The Owner is afforded an opportunity to amend said notices as are reasonably possible.
- 29.03 If the Owner by its inspection determines that the work is substantially complete, it shall prepare a list of all items not satisfactorily completed and shall notify the Contractor and Owner in writing that the work is substantially complete and subject to satisfactory resolution of those items on the list (punch list). Punch lists may be amended from time to time by Owner in the event that additional deficiencies are discovered. In accordance with LSA-R.S. 38:2248(B), any punch list generated during a construction project shall include the cost estimates for the particular items of work the design professional has developed based on the mobilization, labor, material, and equipment costs of correcting each punch list item. The design professional shall retain his working papers used to determine the punch list items cost estimates should the matter be disputed later. The contract agency shall not withhold from payment more than the value of the punch list. Punch list items completed shall be paid upon the expiration of the forty-five (45) day lien period. The provisions of this Section shall not be subject to waiver.
- 29.04 **NOT APPLICABLE-OMITTED** Upon determination of substantial completeness with the punch list, the Contract Time is interrupted and the Contractor is given a reasonable time not to exceed thirty (30) consecutive calendar days to effect final completion by correcting or completing all of those items listed on the punch list. If the items on the punch list are not completed in a satisfactory manner within the thirty day period, then the Contract Time will begin to run again and will include for purposes of determining liquidated damages the thirty day period the grace period being withdrawn.
- 29.05 Upon receipt by Owner of written determination that all work embraced by the contract has been completed in a satisfactory manner, the Owner shall provide a written acceptance to Contractor who shall record Owner's written acceptance with the recorder of Mortgages, St. Tammany Parish. The Contractor shall properly prepare, submit and pay for all costs associated with said Acceptance. The Contractor is also responsible for preparation, re-submission and payment of any and all updated certificates.
- 29.06 Retainage monies, minus those funds deducted in accordance to the requirements of this agreement including but not limited to Paragraph 28.10, shall be due Contractor not earlier than forty-six (46) calendar days after recordation of certificate of Owner's acceptance provided the following:
- (1) Contractor shall prepare, secure, pay for and submit clear lien and privilege certificate, signed and sealed by Clerk of Court or Recorder of Mortgages, Parish of St. Tammany and dated at least forty-six (46) days after recordation of certificate of acceptance;
  - (2) Ensure that the official representative of the Owner has accepted as per LSA-R.S. 38:2241.1, *et seq.* and that all following sub-sections have been properly satisfied as per law;
  - (3) Ensure that all signatures are affixed and that there exists the requisite authority for all signatures;
  - (4) Ensure accurate and proper legal descriptions;

- (5) Properly identify all parties and/or signatories;
- (6) Properly identify all mailing addresses;
- (7) Correctly set for the amount of the contract, together with all change orders;
- (8) Set out a brief description of the work performed;
- (9) Reference to any previously recorded contract, lien or judgment inscription that may affect the property;
- (10) Certification that substantial completion has occurred, together with any applicable date(s);
- (11) Certification that no party is in default and/or that the project has been abandoned.

29.07 After securing the clear lien and privilege certificate the Contractor shall prepare its final application for payment and submit to Owner. The Owner shall approve application for payment, or state its objections in writing and forward to Contractor for resolution.

### 30.00 NOTICE AND SERVICE THEREOF

30.01 Any Notice to Contractor from the Owner relative to any part of this Contract shall be in writing and shall be considered delivered and the service thereof completed when said notice is posted; by certified mail, return receipt requested to the said Contractor at its last given address, or delivered in person to said Contractor or its authorized representative on the Work.

### 31.00 INTENTION OF THESE GENERAL CONDITIONS

31.01 These General Conditions shall be applicable to all contracts entered into by and between the Owner and Contractors, except as may be altered or amended with the consent of the Owner, and/or provided for in the Special Conditions of each contract. Contractor shall be presumed to have full knowledge of these General Conditions which shall be applicable to all contracts containing these General Conditions, whether Contractor has obtained a copy thereof or not.

### 32.00 SEVERABILITY

32.01 If any one or more or part of any of the provisions contained herein and/or in the Specifications and Contract for the Work shall for any reason be held invalid, illegal or unenforceable in any respect, such invalidity, illegality or unenforceability shall not affect any other provisions of this Agreement or attachment, but it shall be construed as if such invalid, illegal, or unenforceable provision or part of a provision had never been contained herein.

32.02 **CHANGING THESE CONDITIONS:** Owner reserves the right to change or modify these General Conditions as it deems best, or as required by law. The General Conditions may also be modified for a particular project by the use of Special Conditions prior to the issuance of the Advertisement for Bid. However, once an advertisement for bid is made for any specific project, any changes to the General Conditions as they affect that specific project must be made in writing and issued via an addendum in accordance with State Law.

### 33.00 LAW OF THE STATE OF LOUISIANA

33.01 The Contract Documents shall be governed by the Law of the State of Louisiana.

33.02 The Contractor agrees to pay reasonable attorney's fees and other reasonable attendant costs, in the event that it becomes necessary for the Owner to employ an attorney in order to enforce compliance with or any remedy relating to any covenants, obligations, or

conditions imposed upon the Contractor by this Agreement. Attorney fees shall be based upon the prevailing hourly rate of attorney rates in the private sector. In no case shall the hourly rate be less than \$175.00 per hour. All attorney fees collected shall be paid the operating budget of the Office of the Parish President.

- 33.03 The jurisdiction and venue provisions shall apply to all contractors, sureties, and subcontractors. The 22nd Judicial District for the Parish of St. Tammany shall be the court of exclusive jurisdiction and venue for any dispute arising from these General Conditions and/or any contract executed in conjunction with these General Conditions. All parties specifically waive any rights they have or may have for removal of any disputes to Federal Court, or transfers to different State District Court.
- 33.04 Contractor warrants that it has and/or had received a copy of these General Conditions at all times material hereto; Contractor further agrees that it has read and fully and completely understands each and every condition herein.
- 33.05 The property description will be more fully set out by an attached exhibit.
- 33.06 The Contractor warrants that it has the requisite authority to sign and enter this agreement.
- 33.07 It is specifically understood and agreed that in the event Contractor seeks contribution from the Parish or pursues its legal remedies for any alleged breach of this agreement by the Parish, then the following list of damages SHALL NOT BE RECOVERABLE BY CONTRACTOR. This list includes, but is not limited to:

1. indirect costs and/or expenses;
2. direct costs and/or expenses;
3. time-related costs and/or expenses;
4. award of extra days;
5. costs of salaries or other compensation of Contractor's personnel at Contractor's principal office and branch offices;
6. expenses of Contractor's principal, branch and/or field offices;
7. any part of Contractor's capital expenses, including any interest on Contractor's capital employed for the work;
8. any other charges related to change orders;
9. overhead and general expenses of any kind or the cost of any item not specifically and expressly included in Cost of Work.

33.08 DEFAULT AND WAIVERS

It is understood that time is of the essence. It is specifically understood between the parties that Contractor waives any and all notice to be placed in default by the Owner. This subsection shall supersede and prime any other subsection herein above that is in conflict. The Owner specifically reserves its right and specifically does not waive the requirement to be placed in default by the Contractor as per law.

- 33.09 St. Tammany Parish Government contracts to be awarded are dependent on the available funding and/or approval by members designated and/or acknowledged by St. Tammany Parish Government. At any time St. Tammany Parish Government reserves the right to cancel the award of a contract if either or both of these factors is deficient.
- 33.10 It is the Parish's policy to provide a method to protest exclusion from a competition or from the award of a contract, or to challenge an alleged solicitation irregularity. It is always better to seek a resolution within the Parish system before resorting to outside agencies and/or litigation to resolve differences. All protests must be made in writing, and shall be concise and logically presented to facilitate review by the Parish. The written protest shall include:
1. The protester's name, address, and fax and telephone numbers and the solicitation, bid, or contract number;
  2. A detailed statement of its legal and factual grounds, including a description of the resulting prejudice to the protester;
  3. Copies of relevant documents;

4. All information establishing that the protester is an interested party and that the protest is timely; and
5. A request for a ruling by the agency; and a statement of the form of relief requested.

The protest shall be addressed to Director of Procurement, St. Tammany Parish Government, P.O. Box 628, Covington, LA 70434.

The protest review shall be conducted by the Parish Procurement Department.

Only protests from interested parties will be allowed. Protests based on alleged solicitation improprieties that are apparent before bid opening, or the time set for receipt of initial proposals must be filed with and received by the Procurement Department BEFORE those deadlines.

Any other protest shall be filed no later than ten (10) calendar days after the basis of the protest is known, or should have been known (whichever is earlier).

The Parish will use its best efforts to resolve the protest within thirty (30) days of the date that it is received by the Parish. The written response will be sent to the protestor via mail and, fax, if a fax number has been provided by the protestor. The protestor can request additional methods of notification.

Last day to submit questions and/or verification on comparable products will be no later than 2:00 pm CST, seven (7) working days prior to the opening date of the bid/proposal due date. Further any questions or inquires must be submitted via fax to 985-898-5227, or via email to [Procurement@stpgov.org](mailto:Procurement@stpgov.org). Any questions or inquires received after the required deadline to submit questions or inquires will not be answered.



# Section 09

## CORPORATE RESOLUTION

EXCERPT FROM MINUTES OF MEETING OF THE BOARD OF DIRECTORS OF INCORPORATED.

AT THE MEETING OF DIRECTORS OF \_\_\_\_\_ INCORPORATED, DULY NOTICED AND HELD ON \_\_\_\_\_, A QUORUM BEING THERE PRESENT, ON MOTION DULY MADE AND SECONDED. IT WAS:

RESOLVED THAT \_\_\_\_\_, BE AND IS HEREBY APPOINTED, CONSTITUTED AND DESIGNATED AS AGENT AND ATTORNEY-IN-FACT OF THE CORPORATION WITH FULL POWER AND AUTHORITY TO ACT ON BEHALF OF THIS CORPORATION IN ALL NEGOTIATIONS, BIDDING, CONCERNS AND TRANSACTIONS WITH THE PARISH OF ST. TAMMANY OR ANY OF ITS AGENCIES, DEPARTMENTS, EMPLOYEES OR AGENTS, INCLUDING BUT NOT LIMITED TO, THE EXECUTION OF ALL BIDS, PAPERS, DOCUMENTS, AFFIDAVITS, BONDS, SURETIES, CONTRACTS AND ACTS AND TO RECEIVE ALL PURCHASE ORDERS AND NOTICES ISSUED PURSUANT TO THE PROVISIONS OF ANY SUCH BID OR CONTRACT, THIS CORPORATION HEREBY RATIFYING, APPROVING, CONFIRMING, AND ACCEPTING EACH AND EVERY SUCH ACT PERFORMED BY SAID AGENT AND ATTORNEY-IN-FACT.

I HEREBY CERTIFY THE FOREGOING TO BE A TRUE AND CORRECT COPY OF AN EXCERPT OF THE MINUTES OF THE ABOVE DATED MEETING OF THE BOARD OF DIRECTORS OF SAID CORPORATION, AND THE SAME HAS NOT BEEN REVOKED OR RESCINDED.

SECRETARY-TREASURER

\_\_\_\_\_

DATE

\_\_\_\_\_



# Section 10 CERTIFICATE OF LIABILITY INSURANCE

DATE (MM/DD/YYYY)

**THIS CERTIFICATE IS ISSUED AS A MATTER OF INFORMATION ONLY AND CONFERS NO RIGHTS UPON THE CERTIFICATE HOLDER. THIS CERTIFICATE DOES NOT AFFIRMATIVELY OR NEGATIVELY AMEND, EXTEND OR ALTER THE COVERAGE AFFORDED BY THE POLICIES BELOW. THIS CERTIFICATE OF INSURANCE DOES NOT CONSTITUTE A CONTRACT BETWEEN THE ISSUING INSURER(S), AUTHORIZED REPRESENTATIVE OR PRODUCER, AND THE CERTIFICATE HOLDER.**

**IMPORTANT: If the certificate holder is an ADDITIONAL INSURED, the policy(ies) must be endorsed. If SUBROGATION IS WAIVED, subject to the terms and conditions of the policy, certain policies may require an endorsement. A statement on this certificate does not confer rights to the certificate holder in lieu of such endorsement(s).**

<b>PRODUCER</b>	<b>CONTACT NAME:</b> <b>PHONE (A/C. No. Ext):</b> _____ <b>FAX (A/C. No):</b> _____ <b>E-MAIL ADDRESS:</b> _____
	<b>INSURER(S) AFFORDING COVERAGE</b>
	<b>NAIC #</b>
<b>INSURED</b>	<b>INSURER A :</b> _____ <b>INSURER B :</b> _____ <b>INSURER C :</b> _____ <b>INSURER D :</b> _____ <b>INSURER E :</b> _____ <b>INSURER F :</b> _____

**COVERAGES**

**CERTIFICATE NUMBER:**

**REVISION NUMBER:**

THIS IS TO CERTIFY THAT THE POLICIES OF INSURANCE LISTED BELOW HAVE BEEN ISSUED TO THE INSURED NAMED ABOVE FOR THE POLICY PERIOD INDICATED. NOTWITHSTANDING ANY REQUIREMENT, TERM OR CONDITION OF ANY CONTRACT OR OTHER DOCUMENT WITH RESPECT TO WHICH THIS CERTIFICATE MAY BE ISSUED OR MAY PERTAIN, THE INSURANCE AFFORDED BY THE POLICIES DESCRIBED HEREIN IS SUBJECT TO ALL THE TERMS, EXCLUSIONS AND CONDITIONS OF SUCH POLICIES. LIMITS SHOWN MAY HAVE BEEN REDUCED BY PAID CLAIMS.

INSR LTR	TYPE OF INSURANCE	ADDL INSR	SUBR WVD	POLICY NUMBER	POLICY EFF (MM/DD/YYYY)	POLICY EXP (MM/DD/YYYY)	LIMITS
	<b>GENERAL LIABILITY</b> <input type="checkbox"/> COMMERCIAL GENERAL LIABILITY <input type="checkbox"/> CLAIMS-MADE <input type="checkbox"/> OCCUR _____ _____ GEN'L AGGREGATE LIMIT APPLIES PER: <input type="checkbox"/> POLICY <input type="checkbox"/> PRO-JECT <input type="checkbox"/> LOC						EACH OCCURRENCE \$ DAMAGE TO RENTED PREMISES (Ea occurrence) \$ MED EXP (Any one person) \$ PERSONAL & ADV INJURY \$ GENERAL AGGREGATE \$ PRODUCTS - COMP/OP AGG \$ _____ \$
	<b>AUTOMOBILE LIABILITY</b> <input type="checkbox"/> ANY AUTO <input type="checkbox"/> ALL OWNED AUTOS <input type="checkbox"/> SCHEDULED AUTOS <input type="checkbox"/> HIRED AUTOS <input type="checkbox"/> NON-OWNED AUTOS						COMBINED SINGLE LIMIT (Ea accident) \$ BODILY INJURY (Per person) \$ BODILY INJURY (Per accident) \$ PROPERTY DAMAGE (Per accident) \$ _____ \$
	<b>UMBRELLA LIAB</b> <input type="checkbox"/> OCCUR <b>EXCESS LIAB</b> <input type="checkbox"/> CLAIMS-MADE DED _____ RETENTION \$ _____						EACH OCCURRENCE \$ AGGREGATE \$ _____ \$
	<b>WORKERS COMPENSATION AND EMPLOYERS' LIABILITY</b> ANY PROPRIETOR/PARTNER/EXECUTIVE OFFICER/MEMBER EXCLUDED? <input type="checkbox"/> Y / <input type="checkbox"/> N / <input type="checkbox"/> A (Mandatory in NH) If yes, describe under DESCRIPTION OF OPERATIONS below						<input type="checkbox"/> WC STATUTORY LIMITS <input type="checkbox"/> OTHER E.L. EACH ACCIDENT \$ E.L. DISEASE - EA EMPLOYEE \$ E.L. DISEASE - POLICY LIMIT \$

**DESCRIPTION OF OPERATIONS / LOCATIONS / VEHICLES (Attach ACORD 101, Additional Remarks Schedule, if more space is required)**

Project Name:  
 Contract #:  
 (Name St. Tammany Parish Government as an additional insured).

**CERTIFICATE HOLDER**

**CANCELLATION**

St. Tammany Parish Government  
 P.O. Box 628  
 Covington, LA 70434

**SHOULD ANY OF THE ABOVE DESCRIBED POLICIES BE CANCELLED BEFORE THE EXPIRATION DATE THEREOF, NOTICE WILL BE DELIVERED IN ACCORDANCE WITH THE POLICY PROVISIONS.**

AUTHORIZED REPRESENTATIVE



## 1. SCOPE OF SERVICES

The Contractor shall furnish all labor and materials and perform all of the work required to build, construct and/or complete in a thorough and workmanlike manner:

«txtScopeSummary»

## 2. CONSTRUCTION DOCUMENTS

It is recognized by the Parties herein that said Construction Documents, including by way of example and not of limitation, the plans and Specifications, General Conditions, Supplementary General Conditions, any addenda thereto, the drawings (if any), and the bid, quote or other procurement documents impose duties and obligations upon the Parties herein, and said Parties thereby agree that they shall be bound by said duties and obligations. For these purposes, all of the provisions contained in the aforementioned Construction Documents are incorporated herein by reference with the same force and effect as though said Construction Documents were herein set out in full. Copies of the aforementioned Construction Documents are in the possession of both the Contractor and the Parish for reference.

**3. TIME FOR COMPLETION**

The work shall be commenced on a date to be specified in a written order of the Parish and shall be completed within «intCompletionTime» calendar days from and after said date.

**4. COMPENSATION TO BE PAID TO THE CONTRACTOR**

The Parish will pay and the Contractor will accept in full consideration for the performance of the Contract the sum of «curREQGrandTotal» dollars.

**5. PERFORMANCE AND PAYMENT BOND**

To these presents personally came and intervened \_\_\_\_\_,  
(Name of Attorney in Fact)  
herein acting for \_\_\_\_\_, a corporation organized  
(Surety)  
and existing under the laws of the State of \_\_\_\_\_, and duly authorized to transact business in the State of Louisiana, as surety, who declared that having taken cognizance of this Contract and of the Construction Documents mentioned herein, he hereby in his capacity as its Attorney in Fact obligates his company, as surety for the said Contractor, unto the said Parish, up to the sum of «curREQGrandTotal». The condition of this performance and payment bond

shall be that should the Contractor herein not perform the Contract in accordance with the terms and conditions hereof, or should said Contractor not fully indemnify and save harmless the Parish from all costs and damages which he may suffer by said Contractor's non-performance or should said Contractor not pay all persons who have fulfilled obligations to perform labor and/or furnish materials in the prosecution of the work provided for herein, including by way of example, workmen, laborers, mechanics, and furnishers of materials, machinery, equipment and fixtures, then said surety agrees and is bound to so perform the Contract and make said payment(s).

Contractor and Parish specifically agree to and recognize (1) the statutory employer relationship existing between the Parish and any employees performing work under this Contract as employees of the Contractor or employees of the "Sub-Contractor", and (2) that the work performed by the employees of the Contractor and the employees of the "Sub-Contractor" is part of the Parish's business, occupation or trade and is essential to the ability of the Parish to generate their products or services, all of which is in accordance with LSA-R.S. 23:1061, and as may be amended.

## **6. LIABILITY AND INDEMNIFICATION**

### **A. Duty to Defend**

Upon notice of any claim, demand, suit, or cause of action against the Parish, alleged to arise out of or be related to this Contract, Contractor shall investigate, handle, respond to, provide defense for, and defend at its sole expense, even if the claim, demand, suit, or cause of action is groundless, false, or fraudulent. The Parish may, but is not required to, consult with or assist the Contractor, but this assistance shall not affect the Contractor's obligations, duties, and responsibilities under this section. Contractor shall obtain the Parish's written consent before entering into any settlement or dismissal.

### **B. Contractor Liability**

Contractor shall be liable without limitation to the Parish for any and all injury, death, damage, loss, destruction, damages, costs, fines, penalties, judgments, forfeitures, assessments, expenses (including attorney fees), obligations, and other liabilities of every name and description, which may occur or in any way arise out of any act or omission of Contractor, its owners, agents, employees, partners or subcontractors.

**C. Force Majeure**

It is understood and agreed that neither party can foresee the exigencies beyond the control of each party which arise by reason of an Act of God or force majeure; therefore, neither party shall be liable for any delay or failure in performance beyond its control resulting from an Act of God or force majeure. The Parish shall determine whether a delay or failure results from an Act of God or force majeure based on its review of all facts and circumstances. The parties shall use reasonable efforts, including but not limited to, use of continuation of operations plans (COOP), business continuity plans, and disaster recovery plans, to eliminate or minimize the effect of such events upon the performance of their respective duties under this Contract.

**D. Indemnification**

Contractor shall fully indemnify and hold harmless the Parish, without limitation, for any and all injury, death, damage, loss, destruction, damages, costs, fines, penalties, judgments, forfeitures, assessments, expenses (including attorney fees), obligations, and other liabilities of every name and description, which may occur or in any way arise out of any act or omission of Contractor, its



owners, agents, employees, partners or subcontractors. The Contractor shall not indemnify for the portion of any loss or damage arising from the Parish's act or failure to act.

**E. Intellectual Property Indemnification**

Contractor shall fully indemnify and hold harmless the Parish, without limitation, from and against damages, costs, fines, penalties, judgments, forfeitures, assessments, expenses (including attorney fees), obligations, and other liabilities in any action for infringement of any intellectual property right, including but not limited to, trademark, trade-secret, copyright, and patent rights.

When a dispute or claim arises relative to a real or anticipated infringement, the Contractor, at its sole expense, shall submit information and documentation, including formal patent attorney opinions, as required by the Parish.

If the use of the product, material, service, or any component thereof is enjoined for any reason or if the Contractor believes that it may be enjoined, Contractor, while ensuring appropriate migration and implementation, data integrity, and

minimal delays of performance, shall at its sole expense and in the following order of precedence: (i) obtain for the Parish the right to continue using such product, material, service, or component thereof; (ii) modify the product, material, service, or component thereof so that it becomes a non-infringing product, material, or service of at least equal quality and performance; (iii) replace the product, material, service, or component thereof so that it becomes a non-infringing product, material, or service of at least equal quality and performance; or, (iv) provide the Parish monetary compensation for all payments made under the Contract related to the infringing product, material, service, or component, plus for all costs incurred to procure and implement a non-infringing product, material, or service of at least equal quality and performance. Until this obligation has been satisfied, the Contractor remains in default.

The Contractor shall not be obligated to indemnify that portion of a claim or dispute based upon the Parish's unauthorized: i) modification or alteration of the product, material or service; ii) use of the product, material or service in combination with other products not furnished by Contractor; or, iii) use of the

product, material or service in other than the specified operating conditions and environment.

## **7. MODIFICATION OF CONTRACT TERMS**

Provided that any alterations which may be made in the terms of the Contract or in the work to be done under it, or the giving by the Parish of any extensions of time for the performance of the Contract, or any other forbearance on the part of either the Parish or the Contractor to the other shall not in any way release the Contractor or the Surety from their liability hereunder, notice to the Surety of any such alterations, extensions or other forbearance being hereby waived.

## **7. TERMINATION, CANCELLATION, AND SUSPENSION**

### **A. Termination**

The term of this Contract shall be binding upon the Parties hereto until the work has been completed by the Provider and accepted by the Parish, and all payments required to be made to the Provider have been made. But, this Contract may be terminated upon thirty (30) days written notice under any or all of the following conditions:

- 1) By mutual agreement and consent of the Parties hereto;
- 2) By the Parish as a consequence of the failure of the Provider to comply with the terms, progress, or quality of the work in a satisfactory manner, proper allowances being made for circumstances beyond the control of the Provider;
- 3) By either party upon failure of the other party to fulfill its obligations as set forth in this Contract;
- 4) By the Parish with less than thirty (30) days' notice due to budgetary reductions and changes in funding priorities by the Parish;
- 5) In the event of the abandonment of the project by the Parish.

Upon termination, the Provider shall be paid for actual work performed prior to the Notice of Termination, either based upon the established hourly rate for services actually performed, or on a pro-rata share of the basic fee based upon the phase or percentage of work actually completed, depending on the type of compensation previously established under this Contract.

Upon Termination, the Provider shall deliver to the Parish all original documents, notes, drawings, tracings, computer files, and other files pertaining to this Contract or the Work performed, except for the Provider's personal and administrative files.

**B. Cancellation**

The continuation of this Contract is contingent upon the appropriation of funds to fulfill the requirements of the Contract by the Parish. If the Parish fails to appropriate sufficient monies to provide for the continuation of this or any other Contract, or if such appropriation is reduced by the veto of Parish President by any means provided in the appropriations Ordinance to prevent the total appropriation for the year from exceeding revenues for that year, or for any other lawful purpose, and the effect of such reduction is to provide insufficient monies for the continuation of the Contract, the Contract shall terminate on the date of the beginning of the first fiscal year for which funds are not appropriated. It is understood and agreed that paragraph (9)(C) below may preempt this paragraph, all at the exclusive and unilateral option of the Parish.

**C. Suspension**

Should the Parish desire to suspend the work, but not definitely terminate the Contract, the Parish shall supply the Provider with thirty (30) days' notice. The Parish will also

supply Provider thirty (30) days' notice that the work is to be reinstated and resumed in full force. Provider shall receive no additional compensation during the suspension period. The Parties may revisit the terms of this Contract during the suspension period. The suspension shall not exceed six (6) months, unless mutually agreed upon between the Parties.

- D.** Failure to complete or deliver within the time specified or to provide the services as specified in the bid or response will constitute a default and may cause cancellation of the contract. Where the Parish has determined the contractor to be in default. The Parish reserves the right to purchase any or all products or services covered by the contract on the open market and to charge the contractor with the cost in excess of the contract price. Until such assessed charges have been paid, no subsequent bid or response from the defaulting contractor will be considered.
- E.** In the event of a default and/or breach of this agreement and this matter is forwarded to legal counsel, then the prevailing party may be entitled to collect a reasonable attorney fees and all costs associated therewith whether or not litigation is initiated. Attorney fees shall be based upon the current, reasonable prevailing rate for counsel in the private

sector. The Parties agree to be responsible for such attorney fees, together for all with legal interest from date of agreement breach, plus all costs of collection.

- F.** Termination or cancellation of this agreement will not affect any rights or duties arising under any term or condition herein.
- G.** As to the filing of voluntary or involuntary bankruptcy by Provider, Provider agrees that if any execution or legal process is levied upon its interest in this Contract, or if any liens or privileges are filed against its interest, or if a petition in bankruptcy is filed against it, or if it is adjudicated bankrupt in involuntary proceedings, or if it should breach this Contract in any material respect, the Parish shall have the right, at its unilateral option, to immediately cancel and terminate this Contract. In the event that Provider is placed in any chapter of bankruptcy, voluntarily or involuntarily, or otherwise triggers any provision of the preceding sentence herein, it is understood and agreed that all materials, goods and/or services provided shall be and remain the property of the Parish. All rights of Provider as to goods, wares, products, services, materials and the like supplied to Parish shall be deemed forfeited.

## 8. RECORDATION OF CONTRACT

Contractor authorizes Parish to deduct from any payment due herein costs and service fees for recordation of this Contract in full or an excerpt hereof, or any revisions or modifications thereof as required by law. Contractor agrees to execute an excerpt or extract of this agreement for recordation purposes. If Contractor fails to execute such an excerpt, then the Parish shall file and record the entire Contract and all attachments at the expense of Contractor and Parish is hereby authorized to deduct all related costs and service fees from any proceeds due to the Contractor.

## 9. AUTHORITY TO ENTER CONTRACT

The undersigned representative of Contractor warrants and personally guarantees that he/she has the requisite and necessary authority to enter and sign this Contract on behalf of the corporate entity, partnership, etc. The undersigned Parties warrant and represent that they each have the respective authority and permission to enter this Contract. In the event that Contractor is a member of a corporation, partnership, L.L.C., L.L.P., or any other juridical entity, the Parish requires, as an additional provision, that Contractor supply a certified copy of a corporate



**Bond No.:** \_\_\_\_\_

resolution authorizing the undersigned to enter and sign this Contract. Another option to fulfill this additional provision he/she can supply Louisiana Secretary of State Business filings confirming that he/she is a managing member of a corporation, partnership, L.L.C., L.L.P., or any other juridical entity which authorizes the undersigned to enter and sign this Contract.

In Witness thereof, the Parties hereto on the day and year first above written have executed this Contract in **Three (3)** counterparts, each of which shall, without proof or accountancy for the other counterparts, be deemed an original thereof.

**WITNESSES:**

**CONTRACTOR:**

**Bond No.:** \_\_\_\_\_

\_\_\_\_\_  
Signature

\_\_\_\_\_  
Signature

\_\_\_\_\_  
Print Name

\_\_\_\_\_  
Print Name

\_\_\_\_\_  
Signature

\_\_\_\_\_  
Title

\_\_\_\_\_  
Print Name

\_\_\_\_\_  
Date

SAMPLE

Bond No.: \_\_\_\_\_

**WITNESSES:**

**ST. TAMMANY PARISH  
GOVERNMENT:**

\_\_\_\_\_  
Signature

\_\_\_\_\_  
Print Name

\_\_\_\_\_  
Signature

\_\_\_\_\_  
Print Name

\_\_\_\_\_  
Michael B. Cooper  
Parish President

\_\_\_\_\_  
Date

**APPROVED BY:**

\_\_\_\_\_  
Assistant District Attorney- Civil  
Division

\_\_\_\_\_  
Date

\_\_\_\_\_  
(Surety)

\_\_\_\_\_  
Signature

\_\_\_\_\_  
Print Name

**DRAFT**



**ST. TAMMANY PARISH**

Michael B. Cooper  
PARISH PRESIDENT

**UTILITY REPAIR AND MAINTENANCE - Contract No. \_\_\_\_\_**

<b>Task Order No.:</b>	
<b>Parish Account No.:</b>	
<b>MUNIS Account No. :</b>	
<b>Project No.:</b>	
<b>Project String:</b>	
<b>Commodity Code:</b>	
<b>Work Order No.:</b>	
<b>Requisition No.:</b>	
<b>Purchase Order No.:</b>	

As authorized by St. Tammany Parish Government, Department of Utilities and in accordance with the Utility Repair and Maintenance Contract Agreement, this Task Order is entered into this \_\_\_ day of \_\_\_\_\_, 20\_\_\_ by and between: (CONTRACTOR) hereinafter called the "Contractor", and St. Tammany Parish Government, hereinafter called the "Parish". The Contractor is awarded this Task Order and is obligated as follows:

**1. Work Location & Scope**

**A. Project Title:** \_\_\_\_\_

**B. Location:** \_\_\_\_\_

**C. Description of Work:**

**2. Project Estimate**

Item #	Description	Units	Price	Quantity	Amount
				Subtotal	\$0.00
				Mobilization (10% of Subtotal)	\$0.00
				Total	\$0.00

**3. Task Order Milestones:**

Preconstruction Meeting Date: \_\_\_\_\_

NTP Date: \_\_\_\_\_

Calendar Days to Substantial Completion: \_\_\_\_\_

Calendar Days to Final Acceptance: \_\_\_\_\_

**Terms and Conditions:**

Execution of this Task Order by Parish and Contractor shall make it subject to the terms and conditions of the Contract Agreement.

Contractor is authorized to begin performance upon its receipt of a copy of this Task Order signed by the Parish.

**The Effective Date of this Task Order is:** \_\_\_\_\_.

**Parish:** St. Tammany Parish Government

**Contractor:** \_\_\_\_\_

Signature: \_\_\_\_\_

Signature: \_\_\_\_\_

Printed Name: \_\_\_\_\_

Printed Name: \_\_\_\_\_

Title: \_\_\_\_\_

Title: \_\_\_\_\_

Address: \_\_\_\_\_

Address: \_\_\_\_\_

Date: \_\_\_\_\_

Date: \_\_\_\_\_

CAO Signature: \_\_\_\_\_  
(if applicable) Date

Finance: \_\_\_\_\_  
Date

Capital Accountant: \_\_\_\_\_  
Date

<b>Project &amp; Accounts:</b>		
<b>Task Order No.:</b>	<b>Project No.:</b>	<b>Project String:</b>
<b>Munis Account No.:</b>		

## Section 13

### SPECIAL PROVISIONS

1. Location of Work: The work to be done under this Contract Agreement is located in St. Tammany Parish, Louisiana.
2. The General Conditions included in these specifications are St. Tammany Parish Government (Parish) standards for capital projects. Since this is a different type of work, there are some parts of the General Conditions that do not apply, such as:
  - a. There will not be a Notice to Proceed in the usual sense. Task Orders will be issued for each project or group of projects. This Task Order will be the Notice to Proceed for that project or group of projects.
  - b. Payment for each Task Order will be based on the unit prices in the contract.
  - c. Project signs will not be required for these projects.
  - d. If a Work Directive is sufficiently large and the Contractor requests Progress Payments, this will be accommodated and will be based on work completed.

3. Work to be done: The work to be completed under this Agreement consists of furnishing all labor, equipment, and materials, and performing all work required as outlined below:

The work performed under this Contract can be described as utility repair and maintenance. It is intended to supplement work performed by regular maintenance personnel of the Department of Utilities. Types of work contemplated under this contract are listed on the bid form.

The start date of the Contract shall be the date the contract is signed and will end on the next December 31<sup>st</sup> with an option for two separate one (1) year extensions. If approved, the renewals will be dated January 1<sup>st</sup> of each year and end as of December 31<sup>st</sup> of the year. The schedule of Contract items and unit prices provided in the bid proposal shall be used for the term of the contract. Either party may cancel the Contract at the end of the first year with a minimum of ninety (90) days prior written notice, without assigning any reason by St. Tammany Parish or the Contractor.

The Parish reserves the right to purchase only such items and in such quantities as needed for initial Contract period of one (1) year after acceptance of the lowest responsible bid by the Parish governing authority. For this proposal, the definition of Job shall be the work described on any one issued Task Order. Each job shall be estimated as to the quantities and items required to complete the amount of work. Estimated time for completion shall be in accordance to size of the Job and shall be provided on each issued Task Order. Any single Job meeting or exceeding the \$250,000 limit must be bid out independently.

A representative of the Department of Utilities, prior to commencing work, shall show all of the work within the limits of each Job to the Contractor. Appropriate sketches and/or drawings may be furnished to the Contractor for the Job. Work sites may be scattered for an individual Task Order; however, every effort will be made to consolidate the work to minimize scattered work sites. The Contractor shall begin the work on each Task Order within 10 days after issuance unless a shorter response time is required for emergency work or a longer response time is approved by the Department of Utilities.

In the case of an emergency, the Contractor shall mobilize to the job site and have available, within two (2) hours of notification, any repair clamps and other materials necessary for the repair of the utility services. Contractor shall begin work immediately to complete such repairs.

Liquidated damages will not be charged for this work, but failure to complete the work within the required period or failure to respond within required timeframes may be considered a breach of contract due to failure to perform and will be considered in authorizing additional work.

Each Task Order will be issued by letter with appropriate drawings or other attachments as necessary and will designate a Task Order Number and Purchase Order Number. All correspondence, billing, etc., pertaining to the work should reference this Task Order Number designation and Purchase Order Number. The Parish will make payment after receiving and verifying a detailed and itemized invoice. Partial payments will be made only when completion is unduly delayed through no fault of the Contractor, in which case requests for partial payment may be submitted monthly.

All utility work shall be done in accordance with the Department of Utilities' Technical Specifications and Standard Details and Notes. All work and materials shall conform to all applicable Federal, State, and local requirements and regulations governing public water and sewer systems, including but not limited to the State Sanitary Code. Additionally, all work and materials shall conform to the requirements of accepted industry standards, including but not limited to American Water Works Association (AWWA) standards, American National Standards Institute (ANSI) standards, and American Society for Testing and Materials (ASTM) standards. All work is to be performed in compliance with all State, Federal, OSHA, and Contractor safety standards

4. Emergency Work: The Contractor shall be required to have at least one (1) crew that will remain available to the Parish, 24 hours a day, 7 days a week including holidays. Contractor shall mobilize to the Job site within two (2)

hours of notification and have available, any repair clamps and other materials necessary for the repair of the utility services.

5. Protection of Work: Until the acceptance of the work in any Job by the Department of Utilities as evidenced in writing, said work shall be under the charge and care of the Contractor. The Contractor shall take every necessary precaution against damages to any part thereof by the elements or from any other cause. The Contractor shall rebuild, restore, repair, and make good, at his own expense, all injuries or damages to any portion of the work occasioned by any of the above causes before its completion and acceptance.
6. Maintenance of Traffic: The Contractor shall provide for and maintain both through and local traffic at all times and shall conduct his operations in such manner as to cause the least possible interference with traffic at junctions with roads, streets, and driveways. It shall be the Contractor's responsibility to provide suitable warning signs, rolling barricades, flagmen, etc. in order to insure maximum safety for his workmen and the public within the construction area.

In unusual situations, where traffic and physical conditions dictate, the Contractor shall install special signs, uneven pavement markers, or other specified treatment within the construction area when directed by the Parish.

The Contractor and Parish will cooperate in notifying affected residents of this project, and both parties will make a concerted effort in having any parked vehicles removed from the construction area. The Contractor shall be responsible for other traffic control measures such as temporary signs and lighted barricades.

No direct payments will be made for providing and maintaining traffic.

7. Temporary Signs and Barricades: The Contractor shall furnish, install and maintain all barricades, suitable lights, danger signals, and signs; provide watchmen; and comply with all other requirements regarding the protection of the work, workmen and safety of the public. No direct payments will be made for providing and maintaining traffic.
8. Indemnification: The Contractor agrees to indemnify, defend and save harmless the Owner, their consultants, agents and employees, from and against all loss or expense (including costs and attorney's fees) by reason of liability imposed by law upon the Owner, their consultants, agents and employees for damages because of bodily injury, including death at any time resulting there from, sustained by any person or persons or on account of damage to property, including loss of use thereof, arising out of or in consequence of the performance of this work, whether such injuries to person or damage to property is due or claimed to be due to the negligence of the Contractor, his subcontractors, the Owner, their consultants, agents and employees, except only such injury or damage as shall have been occasioned by the sole negligence of the Owner, and their consultants and further excepting such injury or damage due to any professional negligent act, error and omission of the Owner, their consultants, agents and employees.
9. Clean Up: The Contractor shall at all times keep the area free from accumulations of waste material or rubbish caused by its employees or work. The Contractor shall keep all streets clean during operations. Trucks hauling excavated materials, cement, sand, stone, or other loose materials from or to the site shall be loaded so that no spilling will occur. Before trucks leave the site, their loads shall be carefully trimmed to prevent spillage.

The above requirements likewise apply to suppliers making deliveries to the site and the Contractor will be held responsible for compliance by his suppliers. Upon completion and before final acceptance of the work, the Contractor shall remove all falsework, timbers, all surplus dirt and materials, rubbish, temporary structures, roads or drives, shall replace or renew any fences damaged and restore in an acceptable manner all property, both public and private, which may have been used or damaged in the course of construction.

10. Protection of Structures and Facilities: The Contractor shall assume full responsibility for the protection of all buildings and other structures, public and private, including tracks, pavements, curbs, sidewalks, driveways, fences, poles, power, communication lines, signs, hydrants, drainage structures, underground pipes, cables, and conduits.
11. Wherever settlement or lateral movement of structures might occur, the Contractor shall install adequate shoring or underpinning or other means of support. Where necessary such support shall be installed in advance of construction.
12. Removal and Disposal of Water: The Contractor shall provide and maintain adequate pumping and drainage facilities for removal and disposal of water from trenches or other excavation, falsework, piling, debris, or other obstructions placed during construction operations and not a part of the finished work.
13. Sanitation: The Contractor shall provide and maintain such sanitary accommodations for the use of his employees and others engaged in the project as may be necessary to comply with the requirements of the local and State health authorities and as directed by the Parish. The Contractor shall prohibit the committing of nuisances within the work or upon lands about the work, and any employee found violating these provisions shall be removed from the project.
14. Utilities: It is the Contractors responsibility to contact Louisiana One Call to locate all utility lines. The Contractor shall also be responsible for contacting all utility companies prior to construction to verify line locations.

15. Commencement, Prosecution, and Completion: The Contractor shall be required to commence work at a Job under the contract within ten (10) calendar days after receipt by him of the Task Order for each Job unless otherwise agreed to by the Parish. The Contractor shall prosecute the work with faithfulness and energy and shall complete it within the number of calendar days set in the Task Order for that Job.
16. Reimbursement to the Parish for materials used – If the Contractor requires repair clamps or other materials necessary for temporary restoration of damaged utility lines and the repair must be completed before the ordered materials will arrive, the Department of Utilities will provide in-stock items to the Contractor. The Contractor shall reimburse the Department of Utilities based on a detailed invoice furnished by the Department of Utilities.
17. Authority to Solicit and Accept Bids by St. Tammany Parish Government – Nothing in this bid and Contract Agreement shall prohibit the St. Tammany Parish from soliciting for bids, accepting bids and entering into a contract for any and all work delineated in this bid and Contract Agreement, either the same item contained in this Contract Agreement or work similar thereunto.



**TECHNICAL SPECIFICATIONS**

**Technical Specifications**

**TABLE OF CONTENTS**

**MOBILIZATION ..... 1**

**SECTION 1: ROADWAY ..... 2**

**FIBER-REINFORCED PCC ROADWAYS ..... 2**

**EXTRUDED CURBS ..... 3**

**ASPHALTIC PAVEMENTS ..... 3**

**ASPHALTIC TACK COAT ..... 4**

**SAW CUT PAVEMENT ..... 4**

**REMOVE AND RESTORE COMBINATION CONCRETE CURB & GUTTER ..... 5**

**PCC REMOVAL ..... 5**

**ASPHALT REMOVAL ..... 6**

**GRANULAR MATERIAL BASE COURSE ..... 6**

**LIMESTONE BASE COURSE ..... 7**

**SECTION 2: MISCELLANEOUS WORK ..... 8**

**EMERGENCY CALL-OUT FOR SEWER AND WATER WORK ..... 8**

**REMOVAL OF CONCRETE WALKS AND DRIVES ..... 8**

**FIBER-REINFORCED PCC DRIVEWAYS & SIDEWALKS ..... 8**

**EXPLORATORY EXCAVATION ..... 9**

**WELL POINTING ..... 9**

**ST. AUGUSTINE GRASS SOD/ CENTIPEDE SOD ..... 10**

**SEED & FERTILIZE (CENTIPEDE) ..... 10**

**FURNISH AND INSTALL/ TEST/ TAP SS SLEEVE ..... 10**

**FURNISH AND INSTALL DUCTILE FITTINGS (ALL TYPES) ..... 11**

**FURNISH AND INSTALL PVC/ DUCTILE IRON MEGALUG RESTRAINTS ..... 11**

**PIPE RESTRAINTS FOR WATER AND SEWER PIPE ..... 12**

**REMOVAL OF EXISTING SEWER OR WATER PIPES ..... 12**

**FLOWABLE FILL GROUT FOR FILLING ABANDONED PIPE ..... 13**

**SECTION 3: SANITARY SEWER SYSTEM ..... 14**

**SEWER POINT REPAIR ..... 14**

**GRAVITY SEWER PIPE ..... 15**

**UNRESTRAINED PVC SEWER FORCE MAIN ..... 16**

**DIRECTIONAL DRILL SEWER FORCE MAIN (HDPE DR-11) ..... 18**

**FURNISH AND INSTALL SEWER VALVE ..... 20**

**FURNISH AND INSTALL SEWER VALVE BOX (All Sizes and Depths) ..... 21**

**RESETTING EXISTING MANHOLE RINGS & COVERS ..... 21**

**ADJUSTING SEWER MANHOLE ..... 21**

**REPAIR MANHOLE/ LINE CONNECTION ..... 22**

**REHABILITATE MANHOLE BENCH/ TROUGH ..... 22**

**MANHOLE OR WET WELL COATING ..... 23**

**Section 14**

**CLEANING OF THE MANHOLE OR WET WELL.....23**

**REMOVE & REPLACE MANHOLE WALL, MANHOLE CONE .....23**

**FURNISH & INSTALL NEW MANHOLE RINGS & COVERS.....24**

**FURNISH AND INSTALL MANHOLE INSERTS.....24**

**FURNISH AND INSTALL SEWER MANHOLE.....25**

**BYPASS PUMPING of SEWAGE .....26**

**REPAIR/ ADJUST CLEANOUT .....26**

**INSTALLATION OF SEWER CLEANOUT .....27**

**INSTALLATION/REPLACEMENT OF SEWER SERVICES .....27**

**SECTION 4: WATER SYSTEM ..... 28**

**WATER POINT REPAIR.....30**

**FURNISH AND INSTALL PVC WATER PIPE (C900 DR18) .....31**

**DIRECTIONAL DRILL WATER MAIN OR WATER SERVICE LINES.....32**

**FURNISH AND INSTALL WATER VALVE.....34**

**FURNISH AND INSTALL WATER VALVE BOX (All Sizes and Depths) .....35**

**FURNISH AND INSTALL WATER SERVICES.....35**

**FURNISH AND INSTALL FIRE HYDRANT - 5 ¼", 3-WAY .....36**

**FIRE HYDRANTS - RAISING.....37**

## **MOBILIZATION**

---

MOBILIZATION SHALL BE PAID **ONCE FOR EACH TASK ORDER**, EVEN IF THE TASK ORDER HAS MORE THAN ONE SITE. MOBILIZATION WILL BE 10% OF THE SUM OF ALL PAY ITEMS FOR THE TASK ORDER.

MORE THAN ONE MOBILIZATION CHARGE WILL BE ALLOWED **ONLY** WHEN RE-MOBILIZATION IS DUE TO ACTION OF STPG.

**IT IS THE CONTRACTOR'S RESPONSIBILITY TO CHECK WORK SITES PRIOR TO MOBILIZING WORK FORCE TO ENSURE SITE IS READY FOR WORK TO BE DONE.**

**Pay Item**

<b><u>Item No.</u></b>	<b><u>Item</u></b>	<b><u>Unit</u></b>
001	MOBILIZATION	LS

---

## **SECTION 1: ROADWAY**

---

### **FIBER-REINFORCED PCC ROADWAYS**

This item covers the furnishing of all materials and installation of Portland Cement Concrete (PCC) roadway pavements for thickness as shown.

#### **Mix for 1 C.Y. of Fiber-Reinforced Concrete - PCC Roadways**

28-day strength	4000 psi
Cement (ASTM C-150, Type I/II)	4.64 sacks (436 lbs.)
Fly Ash (ASTM C-618)	1.16 sacks(109 lbs.)
Gravel (ASTM C-33, Grade A)	1775 lbs.
Sand (ASTM C-33)	1226 lbs.
Water (potable)	30 gallons (250 lbs.)
Type A Water Reducer (ASTM C-494)	16.35 lbs.
Air entrainment	5% by volume, use per manufacturers specifications
Fiber reinforcement	1.5 lbs/ CY microfibers, as specified below

The fiber reinforcement for all concrete pavement shall be the brand "Matrix Monofilament Microfiber" as manufactured by FRC Industries or prior approved equal, applied throughout the concrete mixture. The cellulose (treated or untreated), AR glass, nylon, and polyester fibers are specifically prohibited from use. The fibrillated and self-fibrillating fibers are also specifically prohibited. The fiber reinforcement shall be applied **at the plant**. The bags must be broken before mixing. Bag size shall be one (1) pound.

Damaged and/or missing dowel bars (longitudinal/ transverse) and Starlugs shall be replaced with new dowel bars. 1-1/8" x 18" painted smooth dowel bars on 12" centers shall be used unless directed otherwise by St. Tammany Parish Government (Parish). The bars shall be drilled and doweled into the existing pavement by drilling 1 1/2" holes to a depth of 9" and filling with an approved epoxy grout before insertion of the dowel bars. Any deformed bars for longitudinal joints or welded wire fabric will be incidental to the bid unit prices under this item. All costs incurred for this task will be incidental to bid unit prices under concrete paving. The bid prices shall also include adequate curing of the concrete placed and the proper sealing of contraction and expansion joints.

The Contractor is advised that the work along roadways will necessarily be done with a split-paving method. It will be important to have at least one side of the roadway open to traffic when workers are not present.

The bid prices should include all costs for labor, equipment, and materials necessary to provide finished PCC paving including curing compound, in place, as described under this item of the bid. All required jointing materials should be included in price bid under each item. The method of jointing shall be the same as the existing joints in the area of work.

The bid prices under this item shall also include cost of providing engineering/ surveying for alignment, grade, profile, survey stakes, and topography when necessary and as required to improve the roadway alignment, curb and gutter layout, drain line installation, etc. The compensation for this shall be incidental to corresponding bid items in the maintenance contract. There is no other

compensation. This includes new roads, extension of existing roads, turning lanes, parking lots, bike and walking trails, etc. All layouts shall be the responsibility of the Contractor. The Contractor shall be responsible for disposal of all construction materials.

The concrete pavement shall be for cured seven (7) days unless otherwise approved by the Parish. If the Contractor uses "high early" strength concrete (3-day curing period) at his discretion, without the approval of the Parish, payment shall be made under the regular (7-day curing) concrete paving item. The Contractor shall be responsible for proper oversight and protection of the pavement during the initial curing time until the concrete is sufficiently set to resist marring or vandalism.

Roadway pavement shall be in accordance with these specifications and/or the Louisiana Department of Transportation & Development (LDOTD) Standard Specifications for Roads and Bridges, latest edition and revisions, Section 601; whichever is more stringent.

**Pay Item**

<b><u>Item No.</u></b>	<b><u>Item</u></b>	<b><u>Unit</u></b>
101	8" THICK OR GREATER PCCP, FIBER REINFORCED (IN PLACE)	SY
102	8" THICK OR GREATER PCCP, HIGH EARLY FIBER REINFORCED (IN PLACE)	SY

**EXTRUDED CURBS**

The PCC mixture for curb construction shall be a minimum of 4000 psi at 28 days concrete and also provide proper workability, curb strength, and minimum contraction cracking. The PCC curbing may be placed by extruding machine or by forming and hand placement at the Contractor's option and will be bonded to holding surface in a manner approved by the Parish, which may include dowelling and/or an approved bonding agent.

The accepted quantities of curbs will be paid at the contract unit price per linear foot per type, including all labor, equipment, and materials incidental to the work.

**Pay Item**

<b><u>Item No.</u></b>	<b><u>Item</u></b>	<b><u>Unit</u></b>
103	PCC ROLL-OVER CURB W/ CURB DOWELS	LF
104	PCC BARRIER CURB W/ CURB DOWELS	LF

**ASPHALTIC PAVEMENTS**

All work and materials for construction of asphaltic pavements shall be in accordance with the Louisiana Department of Transportation & Development (LDOTD) Standard Specifications for Roads and Bridges, latest edition and revisions, Section 501.

The bid prices for this item shall include all cost of labor, equipment and materials necessary to provide finished asphaltic concrete pavement in place as described in the above mentioned specification manual. All survey, initial and final layout of roadway re-construction is incidental to bid items. There is no separate compensation for this work.

The accepted quantities of asphaltic concrete will be paid for at the contract unit price per ton (2,000 pound). No other type of mix will be allowed without prior approval of the Parish. Haul and/ or loading tickets will be issued for each truckload of asphalt delivered by vendor's trucks and placed on the job.

**Pay Item**

<b><u>Item No.</u></b>	<b><u>Item</u></b>	<b><u>Unit</u></b>
105	BITUMINOUS HOT MIX ASPHALT	TON

**ASPHALTIC TACK COAT**

This work consists of preparing and treating existing asphaltic or concrete surface with asphaltic material in accordance with the Louisiana Department of Transportation & Development (LDOTD) Standard Specifications for Roads and Bridges, latest edition and revisions, Section 504.

The tack coat shall be Ultrafuse, NTSS-1HM, or other prior approved equal trackless tack. Tack shall be handled and stored per manufacturer’s recommendations. The Contractor shall provide equipment for preparation of the surface to be tacked and applying the tack per manufacturer’s recommendation. The surface shall be cleaned by sweeping or other approved methods. The edges of existing pavements, which will form joints with new pavement, shall be satisfactorily cleaned before tack coat is applied. The asphalt shall be uniformly applied to a clean dry surface with no bare areas, streaks or puddles using an asphalt distributor at a rate specified by the tack manufacturer.

The tack coats shall be applied in such a manner as to cause the least inconvenience to traffic. The Contractor will be permitted to apply the tack coat one (1) calendar day prior to the mixture laydown; however, when tack coat has been damaged by traffic or contaminated by dirt, dust or mud, the surface shall be cleaned and re-tacked prior to the mixture laydown at no additional cost. The tacked surfaces exposed to traffic for more than 24 hours or damaged due to inclement weather shall be re-tacked at no additional cost. The payment for the asphaltic tack coat shall be included in asphalt pay item.

**SAW CUT PAVEMENT**

The bid prices for this item shall include all costs for labor, material, and equipment necessary to machine cut the full-depth of either PCC or Asphaltic Pavements. The payment shall be paid at the unit per inch of depth per linear foot of cut. All saw cutting shall be pre-approved by the Parish and measured in the field.

**Pay Item**

<b>Item No.</b>	<b>Item</b>	<b>Unit</b>
106	SAW CUT PAVEMENT	IN/LF

**REMOVE AND RESTORE COMBINATION CONCRETE CURB & GUTTER**

The bid prices should include all costs for labor, equipment and material necessary to remove and dispose existing combination concrete curb & gutter and the replacement of the concrete curb and gutter in accordance with the Louisiana Department of Transportation & Development (LDOTD) Standard Specifications for Roads and Bridges, latest edition and revisions, Section 707. All of the excavated material and broken curb shall be hauled off from the job site, if it is not needed by the Parish. Should the Parish desire, the Contractor will dump the broken curb at a designated site.

Contractor shall exercise care so that jointing materials and pavement structures adjacent to the concrete curb and gutter to be removed shall not be damaged. Any pavement structure damaged by the Contractor as a result of negligence, either willful or accidental, will be replaced at the Contractor's expense.

The PCC Mixture for curb and gutter construction shall be a minimum of 4000-psi and also will provide proper workability, curb and gutter strength, and minimum contraction cracking. The PCC curbing may be placed by extruding machine or by forming and hand placement at Contractor's option and will be bonded to holding surface in a manner approved by the Parish, which may include dowelling and/ or an approved bonding agent.

The accepted quantities for curb and gutter will be paid for at the contract unit price per linear foot, including all labor, equipment and materials incidental to the work.

**Pay Item**

<b>Item No.</b>	<b>Item</b>	<b>Unit</b>
107	REMOVE AND RESTORE COMBINATION CONCRETE CURB AND GUTTER	LF

**PCC REMOVAL**

These items cover work generally associated with breaking up, and removing existing PCC Pavements, including curbs. Concrete shall be removed from joint to joint. **Breaking up of PCC Pavement shall be done with a pneumatic pavement breaker. Use of brute force and pounding with excavation buckets will not be an acceptable means of breaking pavement.** Where concrete to be removed has been overlaid with asphalt, the asphaltic thickness is to be added to the concrete thickness and paid as concrete removal. Should the Parish desire, the Contractor will dump the broken concrete at a designated disposal site at no additional expense to the Parish.

The accepted quantities of concrete removed shall be paid for at the contract unit price per square yard for the nominal thickness measured at the site. The bid prices should include all costs for labor, equipment, transportation and materials necessary to remove and dispose existing PCC Pavement.



**Pay Item**

<b><u>Item No.</u></b>	<b><u>Item</u></b>	<b><u>Unit</u></b>
108	PCCP ROADWAY REMOVAL 6" THICK OR LESS	SY
109	PCCP ROADWAY REMOVAL GREATER THAN 6" THICK	SY

**ASPHALT REMOVAL**

These items cover work generally associated with breaking up, and removal of an existing Asphaltic Pavement in order to eliminate a badly deteriorated and/ or failed section of roadway. **Breaking up of asphaltic pavement shall be done with a pneumatic or hydraulic pavement breaker. Use of brute force and pounding with excavation buckets will not be an acceptable means of breaking pavement.**

The accepted quantities of asphalt removed will be paid for at the contract unit price per square yard for the nominal thickness measured at the site. The bid prices should include all costs for labor, equipment, and transportation necessary to remove and dispose existing Asphaltic Pavement for thickness shown.

**Pay Item**

<b><u>Item No.</u></b>	<b><u>Item</u></b>	<b><u>Unit</u></b>
110	ASPHALT REMOVAL - 6" THICK OR LESS	SY
111	ASPHALT REMOVAL - GREATER THAN 6" THICK	SY

**GRANULAR MATERIAL BASE COURSE**

The specifications for base course shall be in accordance with the Louisiana Department of Transportation & Development (LDOTD) Standard Specifications for Roads and Bridges, latest edition and revisions, Sections 301 & 1003.09. Granular material shall conform to the following requirements:

Liquid limit (maximum)      25% (percent)  
Plasticity index (maximum)    6% (percent)

The granular material will be paid for by the cubic yard truck measure. The bid price shall include all costs for material, labor, equipment, hauling, placing, spreading, compacting and grading for this item. This pay item shall be used for repairs to roadway base and for patching roadway base.

**Pay Item**

<b><u>Item No.</u></b>	<b><u>Item</u></b>	<b><u>Unit</u></b>
112	FURNISH AND PLACE GRANULAR BASE COURSE	CY

**LIMESTONE BASE COURSE**

The specifications for limestone shall be in accordance with the Louisiana Department of Transportation & Development (LDOTD) Standard Specifications for Roads and Bridges, latest edition and revisions, Sections 301, 1003.01, & 1003.03.1. In addition, the material shall be calcitic or dolomitic with calcium carbonate not less than 85 percent and the silica content (impurities) not to exceed 5 percent. The limestone used on asphalt pavement shoulder shall be comparable to Mexican limestone in color and gradation.

The material shall conform to the following gradation:

<u>U.S. Sieve</u>	<u>Percent Passing</u>
1 1/2"	100
3/4"	50-100
No. 4	35-65
No.40	10-32
No.200	3-15

The aggregate shall conform to LA DOTD approved materials. The fraction of stone passing the No. 40 sieve shall be non-plastic. The limestone material will be paid for by the cubic yard truck measure. The bid price shall include all costs for material, labor, equipment, hauling, placing, spreading, compacting and grading for this item. This pay item shall be used for repairs to roadway base and for patching roadway base.

**Pay Item**

<b><u>Item No.</u></b>	<b><u>Item</u></b>	<b><u>Unit</u></b>
113	FURNISH AND PLACE LIMESTONE BASE COURSE	CY

## ***SECTION 2: MISCELLANEOUS WORK***

---

### **EMERGENCY CALL-OUT FOR SEWER AND WATER WORK**

As needed and directed by the Parish, the Contractor shall be required to be on-site for an emergency repair of sewer and/or water facilities within two (2) hours, with a superintendent or foreman, to assess the situation. The Contractor shall begin mobilizing the appropriate crew, equipment and materials to the site immediately thereafter. The Contractor shall provide the crew, equipment and material necessary to complete the repair and shall work continuously until the repair is complete or until directed otherwise by the Parish. The emergency call-out for sewer and water work will be measured per each completed and accepted. This pay item will be included with other appropriate pay items to complete the repair and as approved by the Parish.

#### **Pay Item**

<b><u>Item No.</u></b>	<b><u>Item</u></b>	<b><u>Unit</u></b>
201	EMERGENCY CALL-OUT FOR SEWER AND WATER WORK	EA

### **REMOVAL OF CONCRETE WALKS AND DRIVES**

These items cover work generally associated with breaking up and removing existing concrete sidewalks and drives. The bid prices should include all costs for labor, equipment and transportation necessary to remove and dispose existing concrete walks and drives. **Breaking up of PCC Pavement shall be done with a pneumatic pavement breaker. Use of brute force and pounding with excavation buckets will not be an acceptable means of breaking pavement.** Should the Parish desire, the Contractor will dump the broken sidewalks and drives at a designated site at no additional cost to the Parish.

The accepted quantities of sidewalks and drives removed will be paid for at the contract unit price per square yard measured at the site.

#### **Pay Item**

<b><u>Item No.</u></b>	<b><u>Item</u></b>	<b><u>Unit</u></b>
202	REMOVAL OF CONCRETE WALKS & DRIVES	SY

### **FIBER-REINFORCED PCC DRIVEWAYS & SIDEWALKS**

This item covers the furnishing of all materials and installation of PCC driveway and sidewalk pavements for thickness as shown. All sidewalk and driveway work and materials shall be in accordance with the Louisiana Department of Transportation & Development (LDOTD) Standard Specifications for Roads and Bridges, latest edition and revisions, Section 706.

The bid prices shall include all costs for labor, equipment, and materials necessary to provide finished PCC paving, in place, as described under this item of the proposal. All required jointing materials should be included in price bid under each item. The method of jointing shall be the same as the existing joints in the area of work.

The bid prices under this item shall also include cost of providing engineering/ surveying for alignment, grade, profile, survey stakes, and topography when necessary and as required to improve the roadway alignment, curb and gutter layout, drain line installation, etc. The compensation for this shall be incidental to corresponding bid items. There is no other compensation. All layouts shall be the responsibility of the Contractor. The Contractor shall be responsible for disposal of all construction materials.

**Pay Item**

<b><u>Item No.</u></b>	<b><u>Item</u></b>	<b><u>Unit</u></b>
203	FIBER REINFORCED 4" THICK PCC PAVING, IN PLACE FOR SIDEWALK	SY
204	FIBER REINFORCED 6" THICK PCC PAVING, IN PLACE FOR DRIVEWAYS (OR SIDEWALKS, IF SPECIFIED IN TASK ORDER)	SY

**EXPLORATORY EXCAVATION**

The exploratory excavation shall include all materials, equipment, tools, labor, excavation, backfill and incidentals necessary to locate and expose existing water or sewer pipes, fittings or valves. At the direction of the Parish, the Contractor shall backfill the excavation and return the surface to its previous condition in accordance with the standard trench details and specifications. This item will be measured per each Exploratory Excavation completed and accepted. The replacement of pavement, sod, and other incidentals necessary to return topside to original conditions shall be paid under applicable separate bid item.

**Pay Item**

<b><u>Item No.</u></b>	<b><u>Item</u></b>	<b><u>Unit</u></b>
205	EXPLORATORY EXCAVATION	EA

**WELL POINTING**

The well pointing shall be used when directed by the Parish to facilitate proper construction techniques. The well points shall include providing, setting up, operating, and removing a properly-sized pump, header pipes, and well points. If the well points are operated 24 hours a day, the motors shall be equipped with super silencers, unless otherwise approved by the Parish.

The item Well Pointing (Set-Up) shall include:

1. A minimum of four (4) well points operated for a period of eight (8) hours, at a maximum depth of 20 feet and 40 feet of header pipe
2. Sufficient pumping capacity to dewater the construction site

If additional well point pumping is required, it shall be measured and paid per each eight (8) hour period.

Additional well points may be installed to dewater the construction area, as safety dictates. The header pipe shall be measured per linear foot and shall include one (1) well point for each 3 feet of header. No additional payment will be made for increased pumping capacity, if required.

**Pay Item**

<b><u>Item No.</u></b>	<b><u>Item</u></b>	<b><u>Unit</u></b>
206	WELL POINTING (INITIAL SET-UP)	EA
207	WELL POINT PUMPING PER EIGHT HOURS	EA

**ST. AUGUSTINE GRASS SOD/ CENTIPEDE SOD**

This work consists of furnishing, hauling, planting, rolling, watering, and maintaining live grass sod at locations directed by the Parish. The approved sod shall be either field grown or nursery grown grass. The sod should be St. Augustine or Centipede unless otherwise directed by the Parish.

The furnishing, hauling, planting, rolling, and watering shall be in accordance with the Louisiana Department of Transportation & Development (LDOTD) Standard Specifications for Roads and Bridges, latest edition and revisions, Section 714.

Payment for this item shall be made at the contract unit price bid per square yard.

**Pay Item**

<b><u>Item No.</u></b>	<b><u>Item</u></b>	<b><u>Unit</u></b>
208	ST. AUGUSTINE GRASS SOD	SY
209	CENTIPEDE GRASS SOD	SY

**SEED & FERTILIZE (CENTIPEDE)**

This work consists of preparing seedbeds, furnishing and sowing grass seed on the areas designated by the Parish. Preparing of seedbeds shall consist of furnishing and applying fertilizer. The grass shall be centipede or an approved quick-growing species suitable to the area and season. The seeding and associated work shall be in accordance with the appropriate section of the Louisiana Department of Transportation & Development (LDOTD) Standard Specifications for Roads and Bridges, latest edition and revisions, Section 717.

Payment for seeding shall be made at the contract unit price bid per pound.

**Pay Item**

<b><u>Item No.</u></b>	<b><u>Item</u></b>	<b><u>Unit</u></b>
210	SEED & FERTILIZE (CENTIPEDE)	LB

**FURNISH AND INSTALL/ TEST/ TAP SS SLEEVE**

The install, test and tap shall include furnishing the full circle all stainless-steel tapping sleeve, brand "Mueller H-304", "Romac Industries SST" or approved equal, testing according to the manufacturer's recommendation and tapping the carrier pipe in a sanitary manner recognized by AWWA, and the Louisiana Department of Health & Hospitals.

The payment for this work shall be made at the contract unit price bid per each and shall include all labor, and materials required to complete the installation.

**Pay Item**

<b><u>Item No.</u></b>	<b><u>Item</u></b>	<b><u>Unit</u></b>
211	FURNISH & INSTALL/ TEST/ TAP SS SLEEVE – 4” X ALL SIZES	EA
212	FURNISH & INSTALL/ TEST/ TAP SS SLEEVE – 6” X ALL SIZES	EA
213	FURNISH & INSTALL/ TEST/ TAP SS SLEEVE – 8” X ALL SIZES	EA
214	FURNISH & INSTALL/ TEST/ TAP SS SLEEVE – 10” X ALL SIZES	EA
215	FURNISH & INSTALL/ TEST/ TAP SS SLEEVE – 12” X ALL SIZES	EA
216	FURNISH & INSTALL/ TEST/ TAP SS SLEEVE – 14” X ALL SIZES	EA
217	FURNISH & INSTALL/ TEST/ TAP SS SLEEVE – 16” X ALL SIZES	EA

**FURNISH AND INSTALL DUCTILE FITTINGS (ALL TYPES)**

The fittings for 3" diameter and larger water and sewer mains shall be seal coated ductile iron with mechanical joint ends. The interior liner of ductile iron fittings shall conform to all requirements governing potable water, including but not limited to NSF, AWWA, etc. Ductile iron fitting regardless of use in potable water system shall be free of lead per applicable state and federal regulations and industry standards such as NSF and AWWA. Mechanical joints shall be recommended by the manufacturer for use with AWWA C-900 pipe. Fittings shall be manufactured in accordance with AWWA C-110.

Ductile iron fittings used in potable water use shall be installed in a sanitary manner recognized by AWWA, and the Louisiana Department of Health & Hospitals. Disinfection of ductile iron fittings shall in accordance with this document in addition to state and federal regulations.

The payment for this work shall be made at the contract unit price bid per pound and shall include all marking tape, testing, etc. Prior to invoice, the Contractor shall submit the manufacturer’s literature or specification sheet on the weight for each fitting used and the NSF 61 certification.

**Pay Item**

<b><u>Item No.</u></b>	<b><u>Item</u></b>	<b><u>Unit</u></b>
218	FURNISH & INSTALL DUCTILE FITTINGS (ALL TYPES, ALL SIZES)	LB

**FURNISH AND INSTALL PVC/ DUCTILE IRON MEGALUG RESTRAINTS**

This item covers locked mechanical joint retainer glands of adequate strength to prevent movement. The locked mechanical joint retainer glands shall be ductile iron retainer glands equipped with hardened, cupped end set screws. The assembly shall be designed for minimum pressure of 250 psi.

The payment for all ductile iron fittings and retainer glands shall be made at the contract unit price bid per pound. Prior to invoice, the Contractor shall submit the manufacturer’s literature or specification sheet on the weight for each fitting used.

**Pay Item**

<b><u>Item No.</u></b>	<b><u>Item</u></b>	<b><u>Unit</u></b>
219	FURNISH & INSTALL PVC/ DUCTILE IRON MEGALUG RESTRAINTS	LB

**PIPE RESTRAINTS FOR WATER AND SEWER PIPE**

The PVC pipe shall be restrained using the series 1100 PV or 1100 HV Megalug mechanical joint thrust restraint as manufactured by EBAA Iron, Inc. or prior approved equal. The EBAA Iron series 1100 PV or 1100 PV Megalug assembly shall be cast completely of closely controlled Ductile Iron conforming to ASTM A536, latest revision, and furnished with Silicone Bronze IFI140 grade 655 bolts. All glands and bolts shall be coated with two (2) coats of coal tar epoxy, Koppers 300-m bitumastic or prior approved equal, with a minimum dry film thickness of 8 mils per coat.

All restrained joints shall be inspected at the job site after installation. Field touch-up and repair if needed shall be made by the Contractor under the supervision and inspection of a representative of the coating supplier.

All pipe and fittings shall be subjected to a rigid inspection after delivery to the site and before being placed in the work. Any piece found defective by such field inspection will be rejected and shall be immediately removed from the premises. Pressure testing of sewer force mains and water mains shall be in accordance with AWWA standards, industry standards, and requirements of this document.

**Pay Item**

<b><u>Item No.</u></b>	<b><u>Item</u></b>	<b><u>Unit</u></b>
220	PIPE RESTRAINTS (3") (WATER OR SEWER)	EA
221	PIPE RESTRAINTS (4") (WATER OR SEWER)	EA
222	PIPE RESTRAINTS (6") (WATER OR SEWER)	EA
223	PIPE RESTRAINTS (8") (WATER OR SEWER)	EA
224	PIPE RESTRAINTS (10") (WATER OR SEWER)	EA
225	PIPE RESTRAINTS (12") (WATER OR SEWER)	EA
226	PIPE RESTRAINTS (14") (WATER OR SEWER)	EA
227	PIPE RESTRAINTS (16") (WATER OR SEWER)	EA

**REMOVAL OF EXISTING SEWER OR WATER PIPES**

All existing water and/or sewer pipes shall be removed as directed by the Parish and shall be disposed of in accordance with all Federal, State and Local regulations and laws. Measurement and Payment for "Removal of Existing Sewer or Water Mains" shall be made per linear foot.

**Pay Item**

<b><u>Item No.</u></b>	<b><u>Item</u></b>	<b><u>Unit</u></b>
228	REMOVAL OF EXISTING SEWER OR WATER PIPES	LF

**FLOWABLE FILL GROUT FOR FILLING ABANDONED PIPE**

This work includes all equipment, labor, and materials to furnish and install flowable fill inside abandoned pipe. The mix design for flowable fill shall be either the brand “Rheocell® Rheofill, Mix 2” or other prior approved equal. When specified by the Parish (generally, when line is not under a roadway), air holes shall be dug every 200 feet to avoid airlocks. Flowable fill shall be in accordance with the Louisiana Department of Transportation & Development (LDOTD) Standard Specifications for Roads and Bridges, latest edition and revisions, Section 710.

The flowable fill shall be produced and delivered at a minimum temperature of 50° F. Do not place flowable fill if ambient air temperature of 35° F or less is anticipated within the 24-hour period following placement. Water shall not be added to the mixture after batching. All pipes, manholes, catch basins, and other areas not intended to be filled shall be tightly sealed prior to placement.

The payment for flowable fill shall be made per cubic yard of flowable fill placed. All preliminary testing, furnishing mix design, pump, cleanup, and other materials, equipment or labor necessary to complete the work as described in the task order shall be included in the flowable fill item and will not be paid for separately.

**Pay Item**

<b><u>Item No.</u></b>	<b><u>Item</u></b>	<b><u>Unit</u></b>
229	FLOWABLE FILL GROUT	CY



## ***SECTION 3: SANITARY SEWER SYSTEM***

---

The price and payment for pay items in this section shall be inclusive of all labor, materials, and equipment to construct or repair any segment of the sanitary sewer system. The sanitary sewer system shall consist of all applicable parts of manholes, sewer mains, house connections, fittings, couplings, and any other required incidentals. The work performed under these pay items shall include all excavation, trenching, shoring, dewatering, bedding, pipe laying, backfill, tie-ins to existing sewer lines, acceptance testing of mains, manholes, and all incidental work necessary for a complete and functional sewer collection system.

There will be no direct payment for the removal and disposal of sewer pipe, fittings, valves, manholes, etc., unless otherwise specified. There shall be no direct payment for bypass pumping, dewatering, and/or cleaning of new sewer mains and service connections, installed by the Contractor, as part of the final inspection and acceptance.

### **SEWER POINT REPAIR**

A sewer point repair shall include all materials, fittings, equipment, tools, excavation, shoring, dewatering, bedding, backfill, labor, and incidentals necessary to expose existing sewer line (gravity main and sewer force main), make necessary repairs, backfill, and return the surface area to conditions that existed prior to construction. This item includes the replacement of up to 12 linear feet of pipe and any fittings needed to make the repair. The payment for additional replacement over 12 linear feet shall be paid under applicable separate pay items. The replacement of pavements, sod and other incidentals necessary to return topside to original conditions shall be paid under applicable separate pay items. All materials used shall conform to the applicable sections of these specifications.

If a point repair is performed on a mainline sewer with a sewer house connection, the Contractor will be responsible for reconnecting this service line to the mainline sewer. The depth of the service line at the point of connection for each property Owner shall be sufficient to permit connection to existing private sewer lines at a minimum grade of 1/8 inch per foot. The Contractor shall verify house connections during excavation. The sewer service lines shall be connected to existing private lines at the back of the sidewalk with an approved adapter. The location of installation of service lines to accommodate future development may be directed by the Parish. Lines installed for future use shall be plugged with an approved adapter behind the cleanout that can be removed without damage to the pipe bells.

Flex-Seal Shielded Adjustable repair coupling shall be as manufactured by Mission Rubber Company, Fernco, or an approved equal. The coupling shall have a stainless-steel shear ring (shield) to prevent pipe misalignment against shear forces from soil compaction, shifting and settling, and improper backfill with a sealing "O" ring under each sealing clamp band. The repair coupling shall meet the requirements of ASTM C 1173. The payment for the shielded adjustable coupling shall be incidental and included in the bid price.

**Pay Item**

<b>Item No.</b>	<b>Item</b>	<b>Unit</b>
301	SEWER POINT REPAIR (2" TO 4" PIPE) (DEPTH 0'-6')	EA
302	SEWER POINT REPAIR (2" TO 4" PIPE) (DEPTH 6.1'-10')	EA
303	SEWER POINT REPAIR (2" TO 4" PIPE) (DEPTH 10.1'-12')	EA
304	SEWER POINT REPAIR (2" TO 4" PIPE) (DEPTH >12')	EA
305	SEWER POINT REPAIR (6" TO 8" PIPE) (DEPTH 0'-6')	EA
306	SEWER POINT REPAIR (6" TO 8" PIPE) (DEPTH 6.1'-10')	EA
307	SEWER POINT REPAIR (6" TO 8" PIPE) (DEPTH 10.1'-12')	EA
308	SEWER POINT REPAIR (6" TO 8" PIPE) (DEPTH >12')	EA
309	SEWER POINT REPAIR (10" TO 12" PIPE) (DEPTH 0'-6')	EA
310	SEWER POINT REPAIR (10" TO 12" PIPE) (DEPTH 6.1'-10')	EA
311	SEWER POINT REPAIR (10" TO 12" PIPE) (DEPTH 10.1'-12')	EA
312	SEWER POINT REPAIR (10" TO 12" PIPE) (DEPTH >12')	EA
313	SEWER POINT REPAIR (14" TO 18" PIPE) (DEPTH 0'-6')	EA
314	SEWER POINT REPAIR (14" TO 18" PIPE) (DEPTH 6.1'-10')	EA
315	SEWER POINT REPAIR (14" TO 18" PIPE) (DEPTH 10.1'-12')	EA
316	SEWER POINT REPAIR (14" TO 18" PIPE) (DEPTH >12')	EA

**GRAVITY SEWER PIPE**

All Polyvinyl Chloride (PVC) sewer pipe with a diameter of 6 inches or larger, including pipe for house connections, shall be specifically designed to carry domestic sewage by gravity flow and shall meet the current requirements of American Society for Testing and Materials (ASTM) D 3034 with a maximum SDR equal to 26 and a minimum F/AY stiffness of 115 psi when tested in accordance with ASTM D 2412. All PVC pipe used for sewer gravity mains shall be green in color with text "SEWER" or "SEWER MAIN".

All joints shall consist of an integral bell with a factory installed "locked in" elastomeric gasket. All joints shall meet the current requirements of ASTM D 3212. The spigot end of each joint shall be factory beveled. All fittings shall be standard manufactured fittings that meet the current requirements of ASTM D 3034 and shall be produced by the same company that furnished the PVC sewer pipe.

Connectors and adaptors for joining pipes of similar materials and sizes shall be Flex-Seal Shielded Adjustable repair couplings as manufactured by Mission Rubber Company, Fernco, or an approved equal. The coupling shall have a stainless-steel shear ring (shield) to prevent pipe misalignment against shear forces from soil compaction, shifting and settling, and improper backfill with a sealing "O" ring under each sealing clamp band. The repair coupling shall meet the requirements of ASTM C 1173. The payment for the shielded adjustable coupling shall be incidental and included in the bid price.

The connectors and adaptors for joining pipes of different materials and diameters shall be similar to donuts or flexible couplings as manufactured by Fernco Joint Sealer Company or prior

approved equal. The donuts and couplings must comply with the requirements ASTM C 1173 and/or ASTM C 425.

Metallic marking tape shall be placed in all trenches above new sanitary sewer gravity lines. The tape shall be 3-inch wide metallic tape, green in color, with the words "Caution Sewer Line Buried Below" printed on it. Additionally, tracer wire shall also be placed on the pipe for future locates. No additional compensation will be allowed for supplying or installing this tape or tracer wire.

The Contractor shall provide all materials, equipment, tools, excavation, shoring, dewatering, bedding, backfill, labor, acceptance testing and incidentals necessary to install, or remove and replace, a sewer gravity pipe in accordance with the specifications and standard plans. These pay items include all necessary pipe fittings and couplings not covered by other specific pay items. The payment will be per linear foot of pipe installed horizontally through manholes along the centerline of pipeline. The replacement of pavement, sod, and other incidentals necessary to return topside to original conditions shall be paid under applicable separate bid item.

**Pay Item**

<b><u>Item No.</u></b>	<b><u>Item</u></b>	<b><u>Unit</u></b>
317	GRAVITY SEWER PIPE 8-INCH (PVC, SDR 26) (0'-6' DEPTH)	LF
318	GRAVITY SEWER PIPE 8-INCH (PVC, SDR 26) (6.1'-10' DEPTH)	LF
319	GRAVITY SEWER PIPE 8-INCH (PVC, SDR 26) (10.1'-12' DEPTH)	LF
320	GRAVITY SEWER PIPE 8-INCH (PVC, SDR 26) (>12' DEPTH)	LF
321	GRAVITY SEWER PIPE 10-INCH (PVC, SDR 26) (0'-6' DEPTH)	LF
322	GRAVITY SEWER PIPE 10-INCH (PVC, SDR 26) (6.1'-10' DEPTH)	LF
323	GRAVITY SEWER PIPE 10-INCH (PVC, SDR 26) (10.1'-12' DEPTH)	LF
324	GRAVITY SEWER PIPE 10-INCH (PVC, SDR 26) (>12' DEPTH)	LF
325	GRAVITY SEWER PIPE 12-INCH (PVC, SDR 26) (0'-6' DEPTH)	LF
326	GRAVITY SEWER PIPE 12-INCH (PVC, SDR 26) (6.1'-10' DEPTH)	LF
327	GRAVITY SEWER PIPE 12-INCH (PVC, SDR 26) (10.1'-12' DEPTH)	LF
328	GRAVITY SEWER PIPE 12-INCH (PVC, SDR 26) (>12' DEPTH)	LF

**UNRESTRAINED PVC SEWER FORCE MAIN**

The sewer force main shall be SDR 26 or C900 pipe laid at the location and depths determined by the Parish. All PVC pipe used for sewer force mains shall be green in color with text "SEWER" OR "SFM". If it is determined by the Parish, that a portion of the force main should be restrained, the cost for mechanical joint retainer glands shall be paid under the bid item entitled "PVC/DUCTILE IRON MEGALUG RESTRAINTS."

The excavation, shoring, dewatering, backfill, and compaction required for the installation of the force main shall be included in the linear feet bid price. The Contractor shall excavate the sewer force main trench adequately in advance of any pipe installation as to uncover potential conflicts with the sewer force main. Should conflicts arise the Contractor shall deflect the force main above or below the conflicting utility or house connection.

Where the length of force main being installed is less than 50 feet, the Contractor shall excavate the entire length of the trench. In the event of a conflict, the Contractor shall deflect the force main above or below the conflicting utility or house connection or install a vertical offset in the force main in conformance to the Department of Utilities Standard Details.

The installation of force main pipe shall be strictly in accordance with the manufacturer's specifications, technical data, and instructions. Proper implements, tools and facilities shall be provided and used by the Contractor for the safe and convenient prosecution of the work. All pipe, fittings, and appurtenances shall be carefully lowered into the trench piece by piece by means of a derrick, ropes, or other suitable tools or equipment in such a manner as to prevent damage to materials and protective coatings and linings. Under no circumstances shall materials be dropped or dumped into the trenches.

Every precaution shall be taken to prevent foreign material from entering the pipe while it is being placed in the line. If the pipe laying crew cannot put the pipe into the trench and in place without getting earth into it, a heavy, tightly woven canvas bag of suitable size shall be placed over each end and left there until the connection is to be made to the adjacent pipe. During the laying operations, no debris, tools, clothing or other material shall be placed in the pipe.

All force mains shall be field-tested. The Contractor shall supply all labor, equipment, material, gages, pumps, and incidentals required for testing. The test pressure shall be measured at the highest point along the test section.

The testing shall be conducted after backfilling has been completed and before placement of permanent surface. The testing procedure shall be as follows:

- Fill line slowly with water;
- Maintain flow velocity less than 2 feet per second;
- Expel air completely from the line during filling and again before applying test pressure;
- Air shall be expelled by means of taps at points of highest elevation;
- Apply test pressure;
- Measure the quantity of water that must be pumped into the line to maintain pressure within 5 PSI of the test pressure for a period of two (2) hour;
- This quantity is defined as leakage; and
- Carefully examine any exposed pipe, fittings, and joints during the test.

The following shall be determined at the discretion of the Parish.

- 1) Minimum test pressure of 150 psig unless otherwise noted.
- 2) Test duration shall be a minimum of two (2) hours.
- 3) All visible leaks are to be repaired regardless of the amount of leakage. If any test of pipe laid discloses leakage, the Contractor shall, at his own expense, locate and repair the cause of leakage and retest the line. The method of repair must be approved by the Parish.
- 4) Scheduling of testing: the Contractor shall **notify the Parish at least 24 hours prior to each testing**. Pipe may be subjected to pressure testing and leakage testing at any convenient time after partial completing of backfill.

Metallic marking tape shall be placed in all trenches above new sanitary sewer force main lines. The tape shall be 3 inches wide metallic tape, green in color, with the words "Caution Sewer Line Buried Below" printed on it. Additionally, tracer wire shall also be placed on the pipe for future locates. No additional compensation will be allowed for supplying or installing this tape or tracer wire.

**Pay Item**

<b><u>Item No.</u></b>	<b><u>Item</u></b>	<b><u>Unit</u></b>
329	FURNISH & INSTALL 2" SEWER FORCE MAIN (PVC, SDR 26)	LF
330	FURNISH & INSTALL 3" SEWER FORCE MAIN (PVC, SDR 26)	LF
331	FURNISH & INSTALL 4" SEWER FORCE MAIN (PVC, C900 DR18)	LF
332	FURNISH & INSTALL 6" SEWER FORCE MAIN (PVC, C900 DR18)	LF
333	FURNISH & INSTALL 8" SEWER FORCE MAIN (PVC, C900 DR18)	LF
334	FURNISH & INSTALL 10" SEWER FORCE MAIN (PVC, C900 DR18)	LF
335	FURNISH & INSTALL 12" SEWER FORCE MAIN (PVC, C900 DR18)	LF
336	FURNISH & INSTALL 14" SEWER FORCE MAIN (PVC, C900 DR18)	LF
337	FURNISH & INSTALL 16" SEWER FORCE MAIN (PVC, C900 DR18)	LF

**DIRECTIONAL DRILL SEWER FORCE MAIN (HDPE DR-11)**

This item shall include all labor, equipment, and materials necessary to directional drill sewer force main as indicated in the task order, including high-density polyethylene (HDPE) pipe. Directional drilling and pipe installation shall be done only by a Contractor certified for HDPE fusing and experienced in directional drilling. The pipe supplier shall certify in writing that the Contractor is qualified to join, lay, and pull the pipe or a representative of the pipe manufacturer shall be on site to oversee the pipe joining. No direct pay will be allowed for supplier certification or onsite representative.

All piping system components shall be products of one manufacturer and shall conform to the latest edition of ASTM D1248, ASTM 3350, and ASTM F714. The installation shall be in accordance with ASTM D2321. The pipe exterior shall be black in color with green striping and wording stating "SEWER FORCE MAIN" or "SFM". Sanitary sewer pipe interior shall be light in color for internal video inspection.

The shipping lengths shall be assembled into one continuous length at the job site by thermal butt-fusion, in accordance with the manufacturer's recommendations. The resultant joint shall be as strong as the intervening lengths. Each length of pipe shall be inspected and cleaned as necessary to be free of debris immediately prior to joining. The pipe lengths to be joined shall be of the same type, grade, and class of polyethylene compound and supplied from the same raw material supplier. The jointing of pipe and installation of outlets shall be in accordance with the pipe manufacturer's written recommendations. The installation of polyethylene pipe in areas where flotation is probable (whether on land or a subaqueous location) shall conform to manufacturer's recommendation.

The mechanical connections of the polyethylene pipe to auxiliary equipment shall be through flanged connections, which shall consist of the following:

- Polyethylene “sub end” shall be thermally butt-fused to the ends of the pipe;
- Provide ASTM A240, Type 304 stainless steel backing flange, 125-pound, ANSI B16.1 standard, and gaskets as required by the manufacturer; and
- Stainless steel bolts and nuts of sufficient length to show a minimum of three (3) complete threads when the joint is made and tightened to the manufacturer’s standard.

The Re-torque the nuts after four (4) hours.

The polyethylene pipe shall not be crimped in any way during construction. The deflection of polyethylene pipe after installation and backfilling shall not exceed five (5) percent. The fabricated polyethylene bends shall be manufactured by the pipe manufacturer. The SDR of fabricated polyethylene bends shall be equal to SDR of connecting pipe.

When connecting polyethylene pipe to manholes, provide a rubber ring water seal between pipe and manhole. The pipe shall be handled in such a manner that it is not over stressed or damaged by dragging over or dropping onto sharp and cutting objects. Ropes, fabric, or rubber-protected slings and straps shall be used when handling pipes. Chains, cables, or hooks inserted into the pipe ends **shall not be used**. Two (2) slings spread apart shall be used for lifting each length of pipe. The slings shall be positioned at butt-fused joints. The sections of the pipes with cuts and gouges exceeding 10 percent of the pipe wall thickness or kinked sections shall be removed and the ends rejoined.

The open ends of all sections of pipe shall be plugged at night to prevent animals or foreign material from entering the pipe. Stuffing cloth or paper in the open ends of pipe will not be acceptable.

The piping shall be assembled in a manner that does not obstruct adjacent roadways or public activities. The Contractor shall erect temporary fencing around the entry and exit pipe staging areas. **No direct payment shall be made for this temporary fencing.** The pipe shall be hydrostatically tested after joining into continuous lengths prior to installation and again after installation. The testing procedure shall be the same as that described in the section entitled *UNRESTRAINED PVC SEWER FORCE MAIN* of these specifications.

The erosion prevention procedures shall be used during removal and discharge of the water. The acquisition of water for testing will be at no direct pay; however, if Tammany Utilities water is available, it may be used at no cost.

During the drilling, reaming, or pullback operations, the Contractor shall make adequate provisions for handling the drilling fluids or cuttings at the entry and exit pits. To the greatest extent practical, these fluids must not be discharged into the waterway. When the Contractor’s provisions for storage of the fluids or cuttings on site are exceeded, these materials shall be hauled away to a suitable legal disposal site, at no direct pay. The Contractor shall conduct his directional drilling operation in such a manner that drilling fluids are not forced through the sub-bottom into the waterway. After completion of the directional drilling work, the entry and exit pit locations shall be restored to original conditions.

After the pipe is in place, cleaning pigs shall be used to remove residual water and debris. After cleaning, the Contractor shall provide and run a sizing pig to check for anomalies in the form of buckles, dents, excessive out-of-roundness, and any other deformations. The sizing pig run shall be considered acceptable if the survey results indicate that there are no sharp anomalies (e.g., buckles, gouges, and internal obstructions) greater than two (2) percent of the nominal pipe diameter, or excessive ovality greater than five (5) percent of the nominal pipe diameter. The pipe ovality shall be measured as the percent difference between the maximum and minimum pipe diameters.

The payment for directional drilling sewer force main shall include all pipe, pipe fittings, and appurtenances required and all equipment, materials, and labor necessary to completely install the pipe as required in the task order and restore the top side to original conditions. All required cleaning and testing shall also be included in this item. Measurement will be per linear foot of pipe installed.

**Pay Item**

<b><u>Item No.</u></b>	<b><u>Item</u></b>	<b><u>Unit</u></b>
338	DIRECTIONAL DRILL 2" SEWER FORCE MAIN (HPDE DR-11)	LF
339	DIRECTIONAL DRILL 3" SEWER FORCE MAIN (HPDE DR-11)	LF
340	DIRECTIONAL DRILL 4" SEWER FORCE MAIN (HPDE DR-11)	LF
341	DIRECTIONAL DRILL 6" SEWER FORCE MAIN (HPDE DR-11)	LF
342	DIRECTIONAL DRILL 8" SEWER FORCE MAIN (HPDE DR-11)	LF
343	DIRECTIONAL DRILL 10" SEWER FORCE MAIN (HPDE DR-11)	LF
344	DIRECTIONAL DRILL 12" SEWER FORCE MAIN (HPDE DR-11)	LF
345	DIRECTIONAL DRILL 14" SEWER FORCE MAIN (HPDE DR-11)	LF
346	DIRECTIONAL DRILL 16" SEWER FORCE MAIN (HPDE DR-11)	LF

**FURNISH AND INSTALL SEWER VALVE**

The sewer line valves shall be resilient seat gate valves complying with the requirements of AWWA C 509 "Standard for Resilient-Seated Gate Valve for Water and Sewerage Systems." valves shall be Mueller, M&H or other approved equals. The valves shall be finished with a non-rising stem, O-ring seal, standard 2-inch square, operating nut, and shall open by turning the operating nut counter-clockwise. The valve shall be interior coated with protective epoxy coating meeting AWWA C 550. The valve ends shall be flanged and/or mechanical joint as required. The mechanical joints shall be recommended by the manufacturer for use with AWWA C-900 PVC pipe. The bolts to be of type recommended by pipe supplier of material with a minimum 45,000 psi tensile strength with semi-finished heavy nuts in accordance with ANSI/AWWA C111/A 211.11. Valves 2 inches and smaller shall be NIBCO T-113-LF, or prior approved equal, bronze gate valves with non-rising stems.

The payment for installed water valves shall be made at the contract unit price bid per each valve and shall include all testing.

**Pay Item**

<b><u>Item No.</u></b>	<b><u>Item</u></b>	<b><u>Unit</u></b>
347	FURNISH & INSTALL SEWER VALVE - 2"	EA
348	FURNISH & INSTALL SEWER VALVE - 3"	EA
349	FURNISH & INSTALL SEWER VALVE - 4"	EA
350	FURNISH & INSTALL SEWER VALVE - 6"	EA
351	FURNISH & INSTALL SEWER VALVE - 8"	EA
352	FURNISH & INSTALL SEWER VALVE - 10"	EA
353	FURNISH & INSTALL SEWER VALVE - 12"	EA
354	FURNISH & INSTALL SEWER VALVE - 14"	EA
355	FURNISH & INSTALL SEWER VALVE - 16"	EA

**FURNISH AND INSTALL SEWER VALVE BOX (ALL SIZES AND DEPTHS)**

The valve boxes shall be of cast or ductile iron as manufactured by Mueller, Kennedy, M & H, or other approved equals. The covers shall be cast or ductile iron with a designation of "SEWER" embossed on the top side and shall be of the screw down type. The valve boxes shall be the two (2)-piece type, adjustable in length and suitable for installation in roadway surfaces. The valve boxes shall be installed in accordance with the Department of Utilities Standard Notes & Details including installing the valve box flush with the natural ground and utilizing a PVC riser.

The payment for valve boxes shall be made at the contract unit price bid per each box and shall include all labor, and materials required to complete the installation.

**Pay Item**

<b><u>Item No.</u></b>	<b><u>Item</u></b>	<b><u>Unit</u></b>
356	FURNISH & INSTALL SEWER VALVE BOX (ALL SIZES AND DEPTHS)	EA

**RESETTING EXISTING MANHOLE RINGS & COVERS**

This item includes the removal and cleaning of the existing frame and cover, the exposed concrete surface to insure a good bonding surface, resetting and grouting the ring, and resetting the cover. The resetting of the existing manhole rings and covers shall be paid for at the contract unit price bid per each which shall include grouting/ sealing and any other material, labor, equipment, and incidentals necessary to complete this item.

**Pay Item**

<b><u>Item No.</u></b>	<b><u>Item</u></b>	<b><u>Unit</u></b>
357	RESETTING EXISTING MANHOLE RINGS & COVERS	EA

**ADJUSTING SEWER MANHOLE**

If grade adjustments of existing manholes are required, frames and covers shall be removed and structure walls reconstructed as specified for new work. Frames and covers shall be cleaned and placed in good repair (or replaced, if specified). The structures may also be adjusted by means of



metal adjusting rings connected to existing ring by either welding at least 30% of circumference or by using an epoxy system designed for metal – to – metal adhesion.

After removal of existing manhole cover, a suitable temporary cover shall be placed over manhole to prevent debris from entering manhole and to provide for safety of workman and the public until new manhole cover is in place. If rubble and debris fall into a “live” manhole during adjustment operations, the debris shall be removed immediately and before the Contractor leaves the site. If existing sanitary sewer manhole is equipped with an inverter pan to prevent intrusion of storm water, pan shall be removed and reinstalled after completion of manhole adjustment.

Adjusting the sewer manhole shall be paid for at the contract unit price bid per each, which shall include all material, labor, equipment, and incidentals necessary to complete this item.

**Pay Item**

<b><u>Item No.</u></b>	<b><u>Item</u></b>	<b><u>Unit</u></b>
358	ADJUST SEWER MANHOLE	EA

**REPAIR MANHOLE/ LINE CONNECTION**

The repair manhole/ line connection shall be paid for at the contract unit price bid per each which shall include testing, wrapping, and sealing with grout and any other material, labor, equipment, and incidentals necessary to complete this item.

**Pay Item**

<b><u>Item No.</u></b>	<b><u>Item</u></b>	<b><u>Unit</u></b>
359	REPAIR MANHOLE/ LINE CONNECTION	EA

**REHABILITATE MANHOLE BENCH/ TROUGH**

The material used for construction shall be a quick setting cementitious material, and is to be mixed and applied according to manufacturer’s recommendations and shall have the following minimum requirements:

- |  |                  |
|--|------------------|
| 1. Compressive strength (ASTM C – 190) | 6 hrs. 1400 psi  |
| 2. Shrinkage (ASTM C – 596)            | 0% at 90% R.H.   |
| 3. Bond (ASTM C – 321)                 | 28 days, 150 psi |
| 4. Density, when applied               | 105 +(-) pcf     |

The repair shall be performed on all inverts with visible damage or infiltration. After blocking flow through the manhole, and thoroughly cleaning the invert, the quick setting patch mix shall be applied to the invert in an expeditious manner. The mix shall be troweled uniformly onto the damaged invert to repair the bench/ trough to insure a smooth flow without creating any ledges that will trap solid material. The finished invert surfaces shall be smooth and free of ridges. The flow may be re-established in the manhole within 30 minutes after placement of the mix.

The rehabilitation of manhole bench/ trough will be paid at the contract unit price per each which shall include all materials, labor, incidentals, and equipment needed to construct manholes benches and troughs as specified herein and as directed by the Parish.

**Pay Item**

<b><u>Item No.</u></b>	<b><u>Item</u></b>	<b><u>Unit</u></b>
360	REHABILITATE MANHOLE BENCH/ TROUGH	EA

**MANHOLE OR WET WELL COATING**

The sewer manhole or wet well shall be coated with a polymer lining system (epoxy and polyurethane type systems). Approved products include the Tnemec Poly Spec Tuf-Rez Product, the Warren 100% solids System, Raven Lining Systems, Sprayroq, and Spectrashield, or other approved equals. The finished system shall provide 250 mils minimum cover. During application, a wet film thickness gage shall be used to ensure a monolithic coating and uniform thickness.

**Pay Item**

<b><u>Item No.</u></b>	<b><u>Item</u></b>	<b><u>Unit</u></b>
361	SEWER MANHOLE/ WET WELL COATING	SF

**CLEANING OF THE MANHOLE OR WET WELL**

Prior to the rehabilitation and/or repair of a sewer manhole or wet well, the contractor shall clean the manhole or wet well. Cleaning of the manhole or wet well shall be completed in accordance with the instructions and recommendations of the manufacturer for materials used in the rehabilitation and repair of the manhole or wet well. All materials and labor required for cleaning of the manhole or wet well shall be incidental to respective Pay Item(s). There shall be no direct payment for manhole or wet well cleaning.

**REMOVE & REPLACE MANHOLE WALL, MANHOLE CONE**

Precast manholes, wall sections, or cones shall conform to the requirements of ASTM C-478 and shall be furnished with Ram – Nek or an approved equal gasket.

All joints in precast concrete manholes shall be wrapped tightly with a 3-foot band of filter cloth. The cloth shall lap by its width. The filter cloth shall be brand “Mirafi 700 x”, or an approved equal. An approved non – shrink grout shall be used for grouting and service lines into manholes.

The remove and replace manhole wall item shall be paid for at the contract unit price bid per vertical foot which shall include testing and sealing with grout and any other material (including, but not limited to, gaskets, boots, filter cloth wrap, drop pipe, castings, risers and cones, and non-shrink grout), labor, equipment, and incidentals necessary to complete this item.

The bid item for remove and replace manhole cone shall be paid for at the contract unit price bid per each which shall include testing, wrapping, and sealing with grout and any other material (including, but not limited to, gaskets, boots, filter cloth wrap, drop pipe, castings, risers and cones, and non-shrink grout), labor, equipment, and incidentals necessary to complete this item.

The excavation and backfill shall be paid under applicable sewer excavation and backfill items.

**Pay Item**

<b><u>Item No.</u></b>	<b><u>Item</u></b>	<b><u>Unit</u></b>
362	REMOVE & REPLACE MANHOLE WALL	VFT
363	REMOVE & REPLACE MANHOLE CONE	EA

**FURNISH & INSTALL NEW MANHOLE RINGS & COVERS**

The manhole frames and covers shall be East Jordan Iron Works, Dews Foundry, or approved equal. Frame and cover shall weigh not less than 320 pounds for the standard type. The casting for manhole frames, covers and all other iron castings required should be tough gray iron free from injurious defects. The annular bearing planes shall be ground or machined so they will not rock or rattle when crossed by traffic. The allowance shall be made in the patterns so that grinding or machining will not reduce the thickness required. The covers shall fit the frame accurately in any position.

Furnishing and installing new manhole rings and covers shall be paid for at the contract unit price bid per each which shall include grouting/ sealing and any other material, labor, equipment, and incidentals necessary to complete this item. If roadway removal and replacement are required, they will be paid under separate items.

**Pay Item**

<b><u>Item No.</u></b>	<b><u>Item</u></b>	<b><u>Unit</u></b>
364	FURNISH & INSTALL NEW MANHOLE RINGS & COVERS	EA

**FURNISH AND INSTALL MANHOLE INSERTS**

The manhole inserts shall be installed at locations as directed by the Parish. The manhole inserts shall be Cretex Inflow Dishes, or an approved equal. The insert and components shall be manufactured of materials resistant to corrosion from atmospheres containing hydrogen sulfide and dilute sulfuric acid. The manhole insert shall have a method for relieving gas and/or vacuum pressure from manhole.

The manhole frame rim shall be cleaned of all dirt and debris before installing the manhole insert upon the rim. The insert shall be fully seated around the manhole frame rim. Contractor shall provide a manufacturer approved gasket for use with the manhole insert if needed for proper installation. The manhole cover shall be replaced as before to complete the installation.

The manhole inserts including gaskets will be paid for at the contract unit price bid for each insert properly installed. The payment shall include all material, labor, and incidentals necessary to properly install inserts in manholes in accordance with manufacturer's recommendation.

**Pay Item**

<b><u>Item No.</u></b>	<b><u>Item</u></b>	<b><u>Unit</u></b>
365	FURNISH & INSTALL MANHOLE INSERTS	EA

**FURNISH AND INSTALL SEWER MANHOLE**

The precast manholes shall conform to the requirements of ASTM C-478 and shall be furnished with Ram-Nek or an approved equal gasket. All precast manholes shall be cast with Kor-N-Seal I Boot as manufactured by Fernco, or an approved equal, for connecting sanitary sewer pipes to manholes.

All joints in precast concrete manholes shall be wrapped tightly with a 3-foot band of filter cloth. The cloth shall lap by its width. Filter cloth shall be Mirafi 700x or an approved equal. An approved non-shrink grout shall be used for grouting service lines into manholes.

For any sewer manhole where the vertical distance from the flow line of the outgoing sewer to the invert of the incoming sewer exceeds 2 feet, drop pipe shall be built for the incoming sewers.

The manhole frames and covers shall be East Jordan Iron Works, Dews Foundry, or an approved equal. Frame and cover shall weigh not less than 320 pounds for the standard type. Frame and cover shall be included in price for manhole.

The castings for manhole frames, covers and all other iron castings required shall be of tough gray iron free from injurious defects. The annular bearing planes shall be ground or machined so they will not rock or rattle when crossed by traffic. The allowance shall be made in the patterns so that the thickness required will not be reduced by grinding or machining. The covers shall fit the frame accurately in any position. No steps shall be installed in manholes.

The payment for installed manholes shall be made at the contract unit price bid per each manhole. The pay item for the required size and depth of manhole shall include all excavation, shoring, backfilling, testing, labor, equipment, and materials (including, but not limited to, gaskets, boots, filter cloth wrap, drop pipe, castings, risers and cones, and non-shrink grout) to complete manhole installation as specified. All 60-inch manholes are to be installed the same as 48-inch manholes.

**Pay Item**

<b><u>Item No.</u></b>	<b><u>Item</u></b>	<b><u>Unit</u></b>
366	FURNISH & INSTALL 48" CONCRETE SEWER MANHOLE - <10' DEEP	EA
367	FURNISH & INSTALL 48" CONCRETE SEWER MANHOLE - >10' DEEP	EA
368	FURNISH & INSTALL 60" CONCRETE SEWER MANHOLE - <10' DEEP	EA
369	FURNISH & INSTALL 60" CONCRETE SEWER MANHOLE - >10' DEEP	EA

## **BYPASS PUMPING OF SEWAGE**

Bypass pumping of sewage shall consist of all pipe/hoses, fittings, pumps, adapters, flow controls, plugs and fuel required to maintain the flow of sewage during a scheduled or emergency outage. The minimum requirements of the pump shall be as follows.

- |                                   |             |
|-----------------------------------|-------------|
| 1. Min. solids passing            | 4" diameter |
| 2. Min. flow rate                 | 100 gpm     |
| 3. Min. total dynamic head        | 50' TDH     |
| 4. Max. sound level (07:00-21:00) | 70 dB       |
| 5. Max. sound level (21:00-07:00) | 60 dB       |

However, the contractor shall furnish the appropriate number and size of bypass pumps needed to maintain the flow of sewage without spillage or overflow. The contractor shall also provide adequate standby staff required to maintain the operation of the bypass pumping. The pump shall be powered by a diesel or gasoline engine. The bypass pump shall have telemetry on-board to notify the contractor remotely of issues or problems. Any spillage of sewage shall be cleaned up immediately by the contractor.

When Parish determines bypass pumping is required to maintain the flow of sewage, *BYPASS PUMPING* of sewage shall be paid for at the contract unit price bid per hour which shall include all material, labor, standby personnel, equipment, and incidentals necessary to complete this item. The contractor shall furnish all logs documenting the hours of pump operation and certified payroll for standby personnel. Additionally, *INITIAL SET-UP BYPASS PUMPING AND EQUIPMENT* shall be paid for at the contract unit price bid per each initial setup which shall include all material, labor, equipment, and incidentals necessary to complete this item.

### **Pay Item**

<b><u>Item No.</u></b>	<b><u>Item</u></b>	<b><u>Unit</u></b>
370	INITIAL SET-UP BYPASS PUMP AND EQUIPMENT	EA
371	BYPASS PUMPING	HR

## **REPAIR/ ADJUST CLEANOUT**

A repair and adjustment of the necessary sewer cleanout installation shall consist of all pipe, fittings, adapters, and castings and/or cover boxes. The sewer cleanouts are to be repaired as indicated on the sewer standard detail sheet, so that the sewer cleanout plug fitting and cover are flush with the grade line. The sewer cleanout frame and cover are to be adjusted flush with the grade line.

The repair/ adjust sewer cleanout shall be paid for at the contract unit price bid per each which shall include all material, labor, equipment, and incidentals necessary to complete this item.

### **Pay Item**

<b><u>Item No.</u></b>	<b><u>Item</u></b>	<b><u>Unit</u></b>
372	REPAIR/ ADJUST CLEANOUT	EA

## **INSTALLATION OF SEWER CLEANOUT**

A sewer cleanout installation shall consist of all excavation, shoring, dewatering, backfilling, pipe, fittings, adapters, and castings and/ or cover boxes. The sewer cleanouts are to be installed as indicated on the attached sewer standard detail sheet. Sewer cleanout piping is to be installed from the depth of the service lateral to the existing grade line, so that the sewer cleanout plug fitting and cover are flush with the grade line.

The install of the sewer cleanout shall be paid for at the contract unit price bid per each, which shall include all material, labor, equipment, and incidentals necessary to complete this item.

### **Pay Item**

<b><u>Item No.</u></b>	<b><u>Item</u></b>	<b><u>Unit</u></b>
373	FURNISH & INSTALL SEWER CLEANOUT	EA

## **INSTALLATION/REPLACEMENT OF SEWER SERVICES**

The installation of new sewer services shall include all excavation, shoring, dewatering, backfilling, pipe, fittings, clean outs, tools, labor and any other incidentals required to provide a fully functional sewer service. All sewer service lines shall join the main sewer at a wye.

New 4-inch or 6-inch PVC sewer service lines shall be installed from the wyes in all main sewers to a point approximately at the right of way of the street. Unless otherwise directed by the Parish, replacement of a sewer service shall follow the line and grade of the existing service, which will, in most cases, ensure removal of the old services from the ground. The payment for sewer service line installation shall be paid per linear foot from the existing sewer main to a point at the street right of way line. The payment for sewer wye shall be made at the appropriate contract unit price bid per each, depending on size.

Should the Contractor encounter cleanouts on the existing services during their replacement, new cleanouts shall be installed in accordance with the details on the drawings. In the event that a sewer cleanout location is in a driveway, parking lot, etc., the Contractor will install a cast iron cleanout cover. The cleanout cover will be the brand "East Jordan Iron Works Model V-8504" or an approved equal.

### **Pay Item**

<b><u>Item No.</u></b>	<b><u>Item</u></b>	<b><u>Unit</u></b>
374	4" SEWER SERVICE LINE (PVC, SDR 26)	LF
375	6" SEWER SERVICE LINE (PVC, SDR 26)	LF
376	SEWER SERVICE LINE WYE (6" X 4" X 4")	EA
377	SEWER WYE FOR 8" DIAMETER SEWER MAIN	EA
378	SEWER WYE FOR 10" DIAMETER SEWER MAIN	EA
379	SEWER WYE FOR 12" DIAMETER SEWER MAIN	EA

## **SECTION 4: WATER SYSTEM**

---

All PVC, Ductile Iron Pipe, and high-density polyethylene (HDPE) pipe shall be installed and tested according to the following test procedures.

The sections and completed pipe line shall be subjected to a hydrostatic test of no less than 200 psig. This test pressure shall be maintained with no drop-in pressure for at least two (2) hours or for such additional time as the Parish may require. The Contractor shall furnish all materials, equipment, and personnel for the test.

The sections and completed pipeline shall be subjected to pressure tests conforming to AWWA standard C-600-87, section 4 and shall successfully pass the leakage test as determined by the following formula:

In preparation for the pressure testing, the following minimum steps shall be taken:

- A. The pipeline shall be backfilled to the extent that it will be restrained from movement under pressure.
- B. All thrust blocks shall be constructed to withstand test pressure. Temporary bracing shall not be used except at test ends.
- C. If test ends are used, the open end may be sealed with a line cap and shall be adequately braced with a temporary thrust block or timber bracing.
- D. Scheduling of testing: the Contractor shall **notify the Parish at least 24 hours prior to each testing**. Pipe may be subjected to pressure testing and leakage testing at any convenient time after partial completing of backfill. Segments of water lines to be connected to existing water lines shall be chlorinated, flushed and checked for absence of bacteria before the new section of line is pressure tested. The Contractor may at his option pressure test the line before chlorination, provided the new line is not connected to the existing line during the pressure test. This procedure is set forth to prevent contaminated water or water with high chlorine content from begin forced into a line in service through a faulty valve or other device during pressure tests.

Where leakage exists, the necessary repairs or replacements shall be made at no extra cost to the Owner and test shall be repeated as specified above.

After the water main has been completed and a satisfactory hydrostatic test has been made, the Contractor shall disinfect the water mains. The mains shall be thoroughly flushed before introduction of the chlorinating materials.

All new mains and repaired portions of, or extensions to, existing mains shall be chlorinated in accordance with AWWA C651-14 *Disinfecting Water Mains* requirements so that a chlorine residual of not less than 50 ppm remains in the water after 24 hours standing in the pipe.

- A. Rate of application- water from the existing distribution system or other source of supply shall be controlled so as to flow slowly into the newly laid pipeline during the application of chlorine. The rate of chlorine mixture flow shall be in such proportion to the rate of water entering the pipe that the chlorine dose applied to the water entering the newly laid pipe shall produce a residual at least 25 ppm after 24 hours standing.

- B. Prevention of reverse flow - valves shall be manipulated so that the strong chlorine solution in the line being treated will not flow back into the line supply water. Check valves may be used if desired.
- C. Retention period - treated water shall be retained in the pipe long enough to destroy all non-spore-forming bacteria. This period shall be at least 24 hours and should produce a residual not less than 25 ppm at the retention period.

If the circumstances are such that a shorter retention period must be used, the chlorine concentration shall be increased accordingly. For instance, for a contact period of one (1) hour, a 100 ppm chlorine concentration is required. Under these conditions, special care should be taken to avoid attack on pipe, valves, hydrants and other appurtenances.

- D. Chlorinating valves and hydrants - in the process of chlorinating newly laid pipe, all valves or other appurtenances shall be operated while the pipeline is filled with the chlorinating agent.
- E. Final flushing and test - following chlorination, all treated water shall be thoroughly flushed from the newly laid pipeline at its extremities. The replacement water throughout its length shall, upon test, be proved comparable in quality to the water served the public from the existing water supply system and approved by the public health authority having jurisdiction. The Contractor shall coordinate with the Owner on the timing of the sampling giving a minimum of 24 hours advance notice. The Owner shall collect the bacteriological sample and deliver it to the Department of Health and Hospitals for analyses.
- F. Repetition of procedures - should the initial treatment fail to result in the condition specified; the original chlorination procedure shall be repeated until satisfactory results are obtained.

All pressure testing, flushing and disinfection shall be done by the Contractor at no additional compensation.

All PVC, Ductile Iron, and high-density polyethylene (HDPE) pipe and fittings shall meet all applicable NSF 61 requirements. All chemicals used in disinfecting the water pipe and fittings shall meet all applicable NSF 60 requirements.

The non-metallic or non-conductive (current) water lines must be installed with a non-corrosive metallic tape placed directly over and on the center of the facility for its entire length. This applies to both parallel installations and crossings. The tape must be connected to all facilities and appurtenances. The tape shall have a 3 inches width and the words "buried waterline" should be printed on it along its entire length. The tape shall be detect tape as manufactured by the Allen



Systems, Inc., or approved equal. Additionally, tracer wire shall also be placed on the pipe for future locates. The cost of tape and tracer wire shall be included in the cost of the pipe.

### **WATER POINT REPAIR**

A water point repair shall include all materials, fittings, clamps, equipment, tools, excavation, shoring, dewatering, bedding, backfill, labor, and incidentals necessary to expose existing water line (water main and service lines), make necessary repairs, backfill, and return the surface area to conditions that existed prior to construction. This item includes the replacement of up to 12 linear feet of pipe and any fittings or clamps needed to make the repair. The payment for additional replacement over 12 linear feet shall be paid under applicable separate pay items. Replacement of pavements, sod and other incidentals necessary to return topside to original conditions shall be paid under applicable separate pay items. All materials used shall conform to the applicable sections of these specifications.

If a point repair is performed on a water main with a house service connection, the Contractor will be responsible for reconnecting this service line to the water main. The Contractor shall verify house connections during excavation. The location of installation of service lines to accommodate future development may be directed by the Parish.

Full Circle Clamps Single Band as manufactured by Smith Blair, or approved equal, shall be used for applicable repairs. The full circle clamps shall consist of a stainless-steel band, ductile iron lugs, and a nitrile gasket. The payment shall be per each point repair.

### **Pay Item**

<b>Item No.</b>	<b>Item</b>	<b>Unit</b>
401	WATER LINE POINT REPAIR – UP TO 2" (0'-6' DEPTH)	EA
402	WATER LINE POINT REPAIR – UP TO 2" (6.1'-10' DEPTH)	EA
403	WATER LINE POINT REPAIR – UP TO 2" (10.1'-12' DEPTH)	EA
404	WATER LINE POINT REPAIR – UP TO 2" (>12' DEPTH)	EA
405	WATER LINE POINT REPAIR – 3" (0'-6' DEPTH)	EA
406	WATER LINE POINT REPAIR – 3" (6.1'-10' DEPTH)	EA
407	WATER LINE POINT REPAIR – 3" (10.1'-12' DEPTH)	EA
408	WATER LINE POINT REPAIR – 3" (>12' DEPTH)	EA
409	WATER LINE POINT REPAIR – 4" (0'-6' DEPTH)	EA
410	WATER LINE POINT REPAIR – 4" (6.1'-10' DEPTH)	EA
411	WATER LINE POINT REPAIR – 4" (10.1'-12' DEPTH)	EA
412	WATER LINE POINT REPAIR – 4" (>12' DEPTH)	EA
413	WATER MAIN POINT REPAIR – 6" (0'-6' DEPTH)	EA
414	WATER MAIN POINT REPAIR – 6" (6.1'-10' DEPTH)	EA
415	WATER MAIN POINT REPAIR – 6" (10.1'-12' DEPTH)	EA
416	WATER MAIN POINT REPAIR – 6" (>12' DEPTH)	EA
417	WATER MAIN POINT REPAIR – 8" (0'-6' DEPTH)	EA
418	WATER MAIN POINT REPAIR – 8" (6.1'-10' DEPTH)	EA
419	WATER MAIN POINT REPAIR – 8" (10.1'-12' DEPTH)	EA
420	WATER MAIN POINT REPAIR – 8" (>12' DEPTH)	EA
421	WATER MAIN POINT REPAIR – 10" (0'-6' DEPTH)	EA
422	WATER MAIN POINT REPAIR – 10" (6.1'-10' DEPTH)	EA
423	WATER MAIN POINT REPAIR – 10" (10.1'-12' DEPTH)	EA
424	WATER MAIN POINT REPAIR – 10" (>12' DEPTH)	EA
425	WATER MAIN POINT REPAIR – 12" (0'-6' DEPTH)	EA
426	WATER MAIN POINT REPAIR – 12" (6.1'-10' DEPTH)	EA
427	WATER MAIN POINT REPAIR – 12" (10.1'-12' DEPTH)	EA
428	WATER MAIN POINT REPAIR – 12" (>12' DEPTH)	EA
429	WATER MAIN POINT REPAIR – 14" (0'-6' DEPTH)	EA
430	WATER MAIN POINT REPAIR – 14" (6.1'-10' DEPTH)	EA
431	WATER MAIN POINT REPAIR – 14" (10.1'-12' DEPTH)	EA
432	WATER MAIN POINT REPAIR – 14" (>12' DEPTH)	EA
433	WATER MAIN POINT REPAIR – 16" (0'-6' DEPTH)	EA
434	WATER MAIN POINT REPAIR – 16" (6.1'-10' DEPTH)	EA
435	WATER MAIN POINT REPAIR – 16" (10.1'-12' DEPTH)	EA
436	WATER MAIN POINT REPAIR – 16" (>12' DEPTH)	EA

### **FURNISH AND INSTALL PVC WATER PIPE (C900 DR18)**

The PVC water lines shall be C900 DR18 polyvinyl chloride pipe manufactured in accordance with AWWA C900 (latest edition), blue in color, and shall be U.L. listed. The pipe shall be furnished in standard lengths (minimum 20 feet) with integrally cast bells or couplings using elastomeric

gaskets which meet the requirements of ASTM D1869 and F477. All necessary adapters and retaining glands for connection to fittings shall be provided.

The metallic marking tape shall be placed in all trenches above new water lines. The tape shall be 3 inches wide metallic tape, blue in color, with the words "Caution Water Line Buried Below" printed on it. The tracer wire shall also be placed on the pipe for future locates. No additional compensation will be allowed for supplying or installing this tape or tracer wire.

The payment for this work shall be made at the contract unit price bid per linear foot and shall include all excavation, shoring, dewatering, backfilling, labor, materials, marking tape, testing, etc. required to complete the installation.

**Pay Item**

<b><u>Item No.</u></b>	<b><u>Item</u></b>	<b><u>Unit</u></b>
437	FURNISH & INSTALL 4" WATER LINE (PVC, C900 DR18)	LF
438	FURNISH & INSTALL 6" WATER MAIN (PVC, C900 DR18)	LF
439	FURNISH & INSTALL 8" WATER MAIN (PVC, C900 DR18)	LF
440	FURNISH & INSTALL 10" WATER MAIN (PVC, C900 DR18)	LF
441	FURNISH & INSTALL 12" WATER MAIN (PVC, C900 DR18)	LF
442	FURNISH & INSTALL 14" WATER MAIN (PVC, C900 DR18)	LF
443	FURNISH & INSTALL 16" WATER MAIN (PVC, C900 DR18)	LF

**DIRECTIONAL DRILL WATER MAIN OR WATER SERVICE LINES**

This item shall include all labor, equipment, and materials necessary to directional drill water mains and water lines as indicated in the task order. The directional drilling and pipe installation shall be done only by a Contractor experienced in directional drilling. The pipe supplier shall certify in writing that the Contractor is qualified to join, lay, and pull the pipe or a representative of the pipe manufacturer shall be on site to oversee the pipe joining. No direct pay will be allowed for supplier certification or on-site representative.

Water mains constructed of HDPE shall be manufactured in accordance with AWWA C906. All piping system components shall be products of one (1) manufacturer and shall conform to the latest edition of ASTM D1248, ASTM 3350, and ASTM F714. The installation shall be in accordance with ASTM D2321. The pipe exterior shall be black in color with blue striping.

Water service lines made of HDPE and installed by directional drilling methods shall conform to the requirements set forth in the section titled "FURNISH AND INSTALL WATER SERVICES". The pipe exterior shall be black in color with blue striping.

The shipping lengths shall be assembled into one continuous length at the job site by thermal butt-fusion, in accordance with the manufacturer's recommendations. The resultant joint shall be as strong as the intervening lengths. Each length of pipe shall be inspected and cleaned as necessary to be free of debris immediately prior to joining. The pipe lengths to be joined shall be of the same type, grade, and class of polyethylene compound and supplied from the same raw material supplier. The

jointing of pipe and installation of outlets shall be in accordance with the pipe manufacturer's written recommendations and performed by contractor employees certified in PE joint fusion. The installation of polyethylene pipe in areas where flotation is probable (whether on land or a subaqueous location) shall conform to manufacturer's recommendation.

The mechanical connections of the polyethylene pipe to auxiliary equipment shall be through flanged connections, which shall consist of:

- Polyethylene "sub end" shall be thermally butt-fused to the ends of the pipe;
- Provide ASTM A240, Type 304 stainless steel backing flange, 125-pound, ANSI B16.1 standard, and gaskets as required by the manufacturer; and
- Stainless steel bolts and nuts of sufficient length to show a minimum of three complete threads when the joint is made and tightened to the manufacturer's standard.

Then re-torque the nuts after four (4) hours.

The polyethylene pipe shall not be crimped in any way during construction. Deflection of polyethylene pipe after installation and backfilling shall not exceed five (5) percent. The fabricated polyethylene bends shall be manufactured by the pipe manufacturer. The SDR of fabricated polyethylene bends shall be equal to SDR of connecting pipe.

When connecting polyethylene pipe to manholes, provide a rubber ring water seal between pipe and manhole.

The pipe shall be handled in such a manner that it is not over stressed or damaged by dragging over or dropping onto sharp and cutting objects. Ropes, fabric, or rubber-protected slings and straps shall be used when handling pipes. Chains, cables, or hooks inserted into the pipe ends **shall not be used**. Two (2) slings spread apart shall be used for lifting each length of pipe. The slings shall be positioned at butt-fused joints. The sections of the pipes with cuts and gouges exceeding 10 percent of the pipe wall thickness or kinked sections shall be removed and the ends rejoined.

The open ends of all sections of pipe shall be plugged at night to prevent animals or foreign material from entering the pipe. Stuffing cloth or paper in the open ends of pipe will not be acceptable.

The piping shall be assembled in a manner that does not obstruct adjacent roadways or public activities. The Contractor shall erect temporary fencing around the entry and exit pipe staging areas. **No direct payment shall be made for this temporary fencing**. The pipe shall be hydrostatically tested after joining into continuous lengths prior to installation and again after installation. The testing procedure shall be the same as that described at the beginning of this section.

The erosion prevention procedures shall be used during removal and discharge of the water. Acquisition of water for testing will be at no direct pay; however, if Tammany Utilities water is available, it may be used at no cost.

During the drilling, reaming, or pullback operations, the Contractor shall make adequate provisions for handling the drilling fluids or cuttings at the entry and exit pits. To the greatest extent practical, these fluids must not be discharged into the waterway. When the Contractor's provisions for storage of the fluids or cuttings on site are exceeded, these materials shall be hauled away to a suitable legal disposal site, at no direct pay. The Contractor shall conduct his directional drilling operation in such a manner that drilling fluids are not forced through the sub-bottom into the waterway. After completion of the directional drilling work, the entry and exit pit locations shall be restored to original conditions.

After the pipe is in place, cleaning pigs shall be used to remove residual water and debris. After cleaning, the Contractor shall provide and run a sizing pig to check for anomalies in the form of buckles, dents, excessive out-of-roundness, and any other deformations. The sizing pig run shall be considered acceptable if the survey results indicate that there are no sharp anomalies (e.g., buckles, gouges, and internal obstructions) greater than Two (2) percent of the nominal pipe diameter, or excessive ovality greater than five (5) percent of the nominal pipe diameter. The pipe ovality shall be measured as the percent difference between the maximum and minimum pipe diameters.

The payment for directional drilling water main or water service lines shall include all excavation, shoring, dewatering, backfilling, pipe, pipe fittings, and appurtenances required and all equipment, materials, and labor necessary to completely install the pipe as required in the task order and restore the top side to original conditions. All required cleaning and testing shall also be included in this item. The measurement will be per linear foot of pipe installed.

**Pay Item**

<b><u>Item No.</u></b>	<b><u>Item</u></b>	<b><u>Unit</u></b>
444	DIRECTIONAL DRILL ¾" WATER SERVICE LINE (HPDE SDR9)	LF
445	DIRECTIONAL DRILL 1" WATER LINE (HPDE SDR9)	LF
446	DIRECTIONAL DRILL 2" WATER LINE (HPDE SDR9)	LF
447	DIRECTIONAL DRILL 3" WATER LINE (HPDE DR-11)	LF
448	DIRECTIONAL DRILL 4" WATER LINE (HPDE DR-11)	LF
449	DIRECTIONAL DRILL 6" WATER MAIN (HPDE DR-11)	LF
450	DIRECTIONAL DRILL 8" WATER MAIN (HPDE DR-11)	LF
451	DIRECTIONAL DRILL 10" WATER MAIN (HPDE DR-11)	LF
452	DIRECTIONAL DRILL 12" WATER MAIN (HPDE DR-11)	LF
453	DIRECTIONAL DRILL 14" WATER MAIN (HPDE DR-11)	LF
454	DIRECTIONAL DRILL 16" WATER MAIN (HPDE DR-11)	LF

**FURNISH AND INSTALL WATER VALVE**

The water line valves shall be resilient seat gate valves complying with the requirements of AWWA C 509 "Standard for Resilient-Seated Gate Valve for Water and Sewerage Systems." valves shall be Mueller, M&H or other approved equals. The valves shall be finished with a non-rising stem, O-ring seal, standard 2-inch square, operating nut, and shall open by turning the operating nut counter-clockwise. The valve shall be interior coated with protective epoxy coating meeting AWWA

C 550. The valve ends shall be flanged and/or mechanical joint as required. The mechanical joints shall be recommended by the manufacturer for use with AWWA C-900 PVC pipe. The bolts to be of type recommended by pipe supplier of material with a minimum 45,000 psi tensile strength with semi-finished heavy nuts in accordance with ANSI/AWWA CIII/A 211.11. Valves 2 inches and smaller shall be NIBCO T-113-LF, or prior approved equal, bronze gate valves with non-rising stems. All valves shall be NSF 61 certified.

The payment for installed water valves shall be made at the contract unit price bid per each valve and shall include all testing.

**Pay Item**

<b><u>Item No.</u></b>	<b><u>Item</u></b>	<b><u>Unit</u></b>
455	FURNISH & INSTALL WATER VALVE - 3/4" TO 1"	EA
456	FURNISH & INSTALL WATER VALVE - 2"	EA
457	FURNISH & INSTALL WATER VALVE - 3"	EA
458	FURNISH & INSTALL WATER VALVE - 4"	EA
459	FURNISH & INSTALL WATER VALVE - 6"	EA
460	FURNISH & INSTALL WATER VALVE - 8"	EA
461	FURNISH & INSTALL WATER VALVE - 10"	EA
462	FURNISH & INSTALL WATER VALVE - 12"	EA
463	FURNISH & INSTALL WATER VALVE - 14"	EA
464	FURNISH & INSTALL WATER VALVE - 16"	EA

**FURNISH AND INSTALL WATER VALVE BOX (ALL SIZES AND DEPTHS)**

The valve boxes shall be of cast or ductile iron as manufactured by Mueller, Kennedy, M & H, or other approved equals. The covers shall be cast or ductile iron with a designation of "Water" embossed on the top side and shall be of the screw down type. The valve boxes shall be the two (2)-piece type, adjustable in length and suitable for installation in roadway surfaces. Valve boxes shall be installed flush with the natural ground and not located within a ditch. Valve boxes shall have a concentric concrete ring 2" thick by 4" wide that tapers down from the inside of the ring to the outside.

The payment for valve boxes shall be made at the contract unit price bid per each box and shall include all labor, and materials required to complete the installation.

**Pay Item**

<b><u>Item No.</u></b>	<b><u>Item</u></b>	<b><u>Unit</u></b>
465	FURNISH & INSTALL WATER VALVE BOX (ALL SIZES AND DEPTHS)	EA

**FURNISH AND INSTALL WATER SERVICES**

The water service lines shall be PE-3408 black tubing of nominal sizes from 3/4-inch through 2-inch, all with CTS (copper tubing size) outside diameter and a 250 psi rating at 73.4° F. All water

service tubing shall comply with ASTM D2737, SDR 9. The installation of tubing shall be in accordance with manufacturer's recommendation. The care shall be exercised and proper procedures followed in tubing terminations, with tools approved by the manufacturer for this purpose. PVC C900 DR-18 or HDPE DR-11 water pipe will be acceptable for pipe sizes 2 inches and greater.

The corporation stops at a main and water meter shall be Mueller, or approved equal of the appropriate type and size. The stops shall be installed in the main in accordance with pipe manufacturer's recommendations. Care should be taken to not over or under tighten the stops at points where they enter the main.

The payment for water services shall be made at the contract unit price bid per linear foot and shall include all labor, testing, taps, corporation stops, marking tape, and any other materials required to complete the installation.

**Pay Item**

<b><u>Item No.</u></b>	<b><u>Item</u></b>	<b><u>Unit</u></b>
466	FURNISH & INSTALL WATER SERVICES - 3/4"	LF
467	FURNISH & INSTALL WATER SERVICES - 1"	LF
468	FURNISH & INSTALL WATER SERVICES - 2"	LF
469	FURNISH & INSTALL WATER SERVICES - 3"	LF
470	FURNISH & INSTALL WATER SERVICES - 4"	LF
471	FURNISH & INSTALL WATER SERVICES - 6"	LF
472	FURNISH & INSTALL WATER SERVICES - 8"	LF

**FURNISH AND INSTALL FIRE HYDRANT - 5 1/4", 3-WAY**

New fire hydrants shall be a three-way Mueller Centurion No. A423 HS 250, or approved equal with 5 1/4inch valve opening. The length of the lower section of each hydrant shall be appropriate for the depth of the water main. All new hydrants shall be painted chrome/safety yellow. No existing fire hydrant in the vicinity of a new hydrant shall be removed from service until the new hydrant has been installed, tested, and water system pressure is on the hydrant. The lubricate caps and threads with approved lubricant.

The payment for installed fire hydrants shall be made at the contract unit price bid per each hydrant and shall include all labor, equipment, and materials required to complete the installation.

**Pay Item**

<b><u>Item No.</u></b>	<b><u>Item</u></b>	<b><u>Unit</u></b>
473	FURNISH & INSTALL FIRE HYDRANT - 5 1/4", 3 - WAY	EA

**FIRE HYDRANTS - RAISING**

This item covers all labor, materials, and equipment necessary for the raising of existing fire hydrants to the “bury line” on the hydrant and as directed by the Parish. The fire hydrant extensions shall be manufactured by Mueller or an approved equal.

**Pay Item**

<b><u>Item No.</u></b>	<b><u>Item</u></b>	<b><u>Unit</u></b>
474	RAISE EXISTING FIRE HYDRANT - 6” EXTENSION	EA
475	RAISE EXISTING FIRE HYDRANT - 12” EXTENSION	EA
476	RAISE EXISTING FIRE HYDRANT - 18” EXTENSION	EA
477	RAISE EXISTING FIRE HYDRANT - 24” EXTENSION	EA
478	RAISE EXISTING FIRE HYDRANT - 30” EXTENSION	EA
479	RAISE EXISTING FIRE HYDRANT - 36” EXTENSION	EA
480	RAISE EXISTING FIRE HYDRANT - 42” EXTENSION	EA
481	RAISE EXISTING FIRE HYDRANT - 48” EXTENSION	EA







DATE:	
DESCRIPTION OF REVISION	
No.	

DESIGNED BY:	AH/CT
DRAWN BY:	AH
CHECKED BY:	BM/CT
APPROVED BY:	CT
ISSUE DATE:	03/2023
ISSUED BY:	UTILITIES
SHEET SIZE:	ANSI D
SCALE:	

DEPARTMENT OF UTILITIES  
 ST. TAMMANY PARISH GOVERNMENT  
 CONSTRUCTION STANDARDS FOR  
 WATER DISTRIBUTION

SEWER STANDARD DETAILS  
 SEWER FORCE MAINS

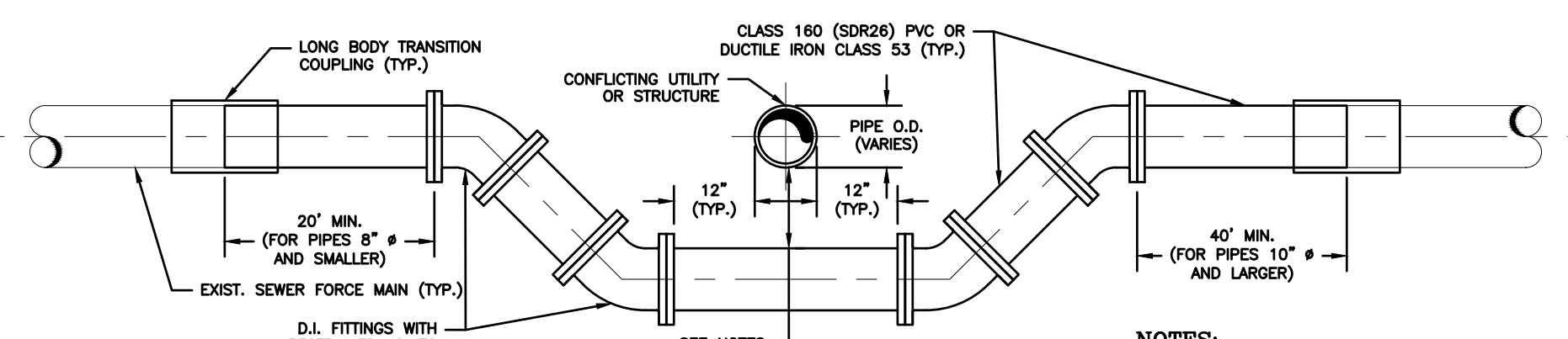

**SEWER FORCE MAIN HORIZONTAL AND VERTICAL (UNDER) OFFSET DETAIL**  
 (NOT TO SCALE)

- NOTES:**
1. THE MINIMUM HORIZONTAL CLEARANCE BETWEEN ALL WATER MAINS AND SEWER LINES/STRUCTURES SHALL BE 18".
  2. ALL SEWER LINES SHALL BE LAID LOWER IN ELEVATION THAN ALL WATER MAINS.
  3. THE MINIMUM HORIZONTAL CLEARANCE BETWEEN ALL WATER MAINS AND OTHER UTILITIES OR STRUCTURES SHALL BE 6".
  4. FLANGE BY FLANGE FITTINGS SHOWN MAY BE REPLACED WITH MJ BY MJ FITTINGS IF THE MJ FITTINGS CAN BE SUFFICIENTLY RESTRAINED.
  5. MINIMUM RESTRAINED LENGTH SHALL BE IN ACCORDANCE WITH DETAIL.

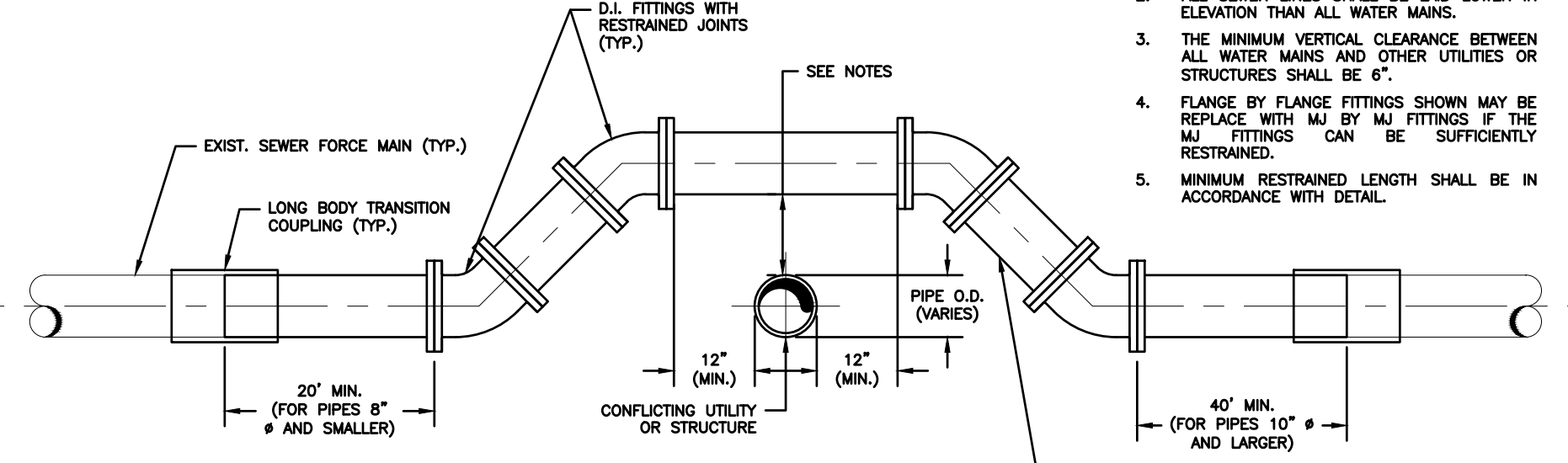

**SEWER FORCE MAIN HORIZONTAL AND VERTICAL (OVER) OFFSET DETAIL**  
 (NOT TO SCALE)

- NOTES:**
1. THE MINIMUM VERTICAL CLEARANCE BETWEEN ALL WATER MAINS AND SEWER LINES/STRUCTURES SHALL BE 18".
  2. ALL SEWER LINES SHALL BE LAID LOWER IN ELEVATION THAN ALL WATER MAINS.
  3. THE MINIMUM VERTICAL CLEARANCE BETWEEN ALL WATER MAINS AND OTHER UTILITIES OR STRUCTURES SHALL BE 6".
  4. FLANGE BY FLANGE FITTINGS SHOWN MAY BE REPLACED WITH MJ BY MJ FITTINGS IF THE MJ FITTINGS CAN BE SUFFICIENTLY RESTRAINED.
  5. MINIMUM RESTRAINED LENGTH SHALL BE IN ACCORDANCE WITH DETAIL.

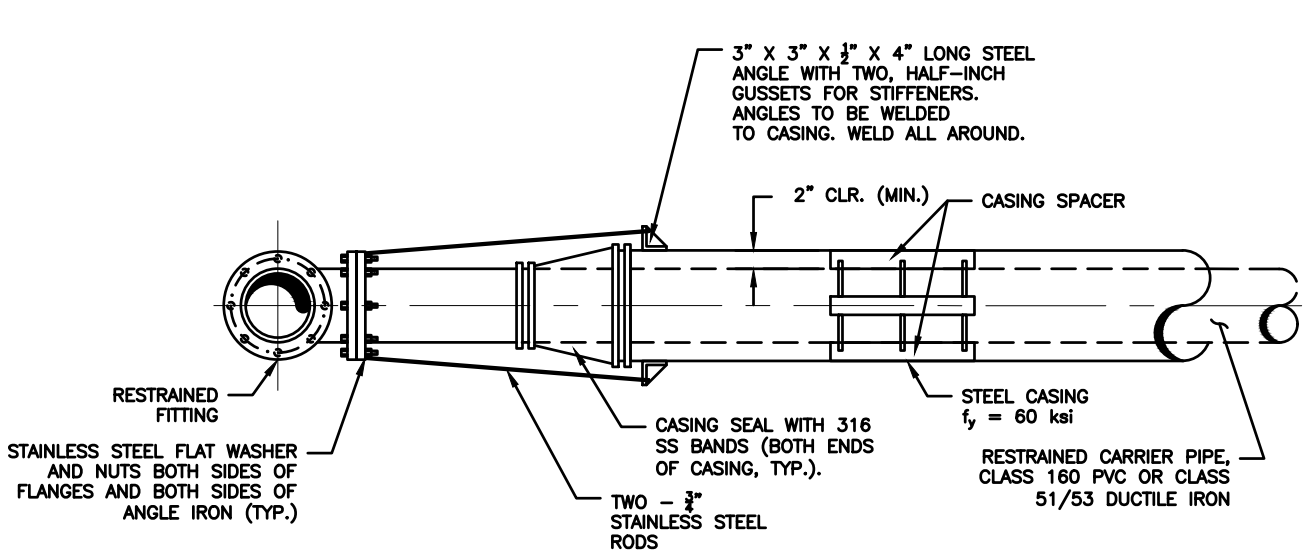

**SEWER FORCE MAIN CASING RESTRAINT DETAIL**  
 (NOT TO SCALE)

- NOTES:**
1. ALL CASING ENDS SHALL BE RESTRAINED TO THE NEAREST FITTING.

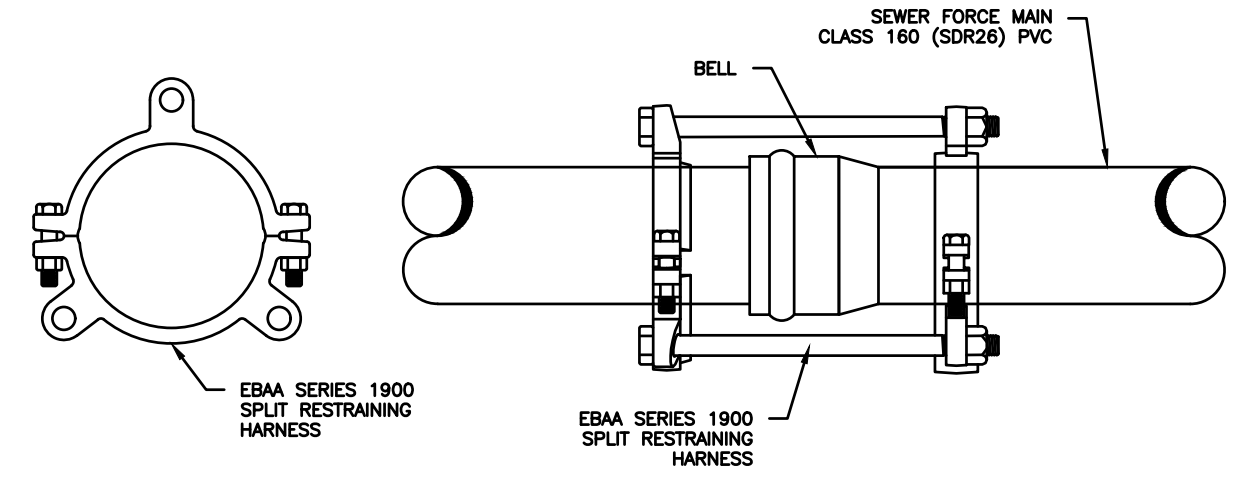

**SEWER FORCE MAIN JOINT RESTRAINING DETAIL**  
 (NOT TO SCALE)

- RESTRAINT NOTES:**
1. THE FOURTH JOINT OF ALL PIPE WITH A BELL AND SPIGOT DESIGN SHALL BE RESTRAINED USING A SPLIT RESTRAINING HARNESS SUCH AS EBAA SERIES 1900 OR OWNER APPROVED EQUAL.
  2. PIPE GASKETS SHALL CONFORM TO ANWA C111.

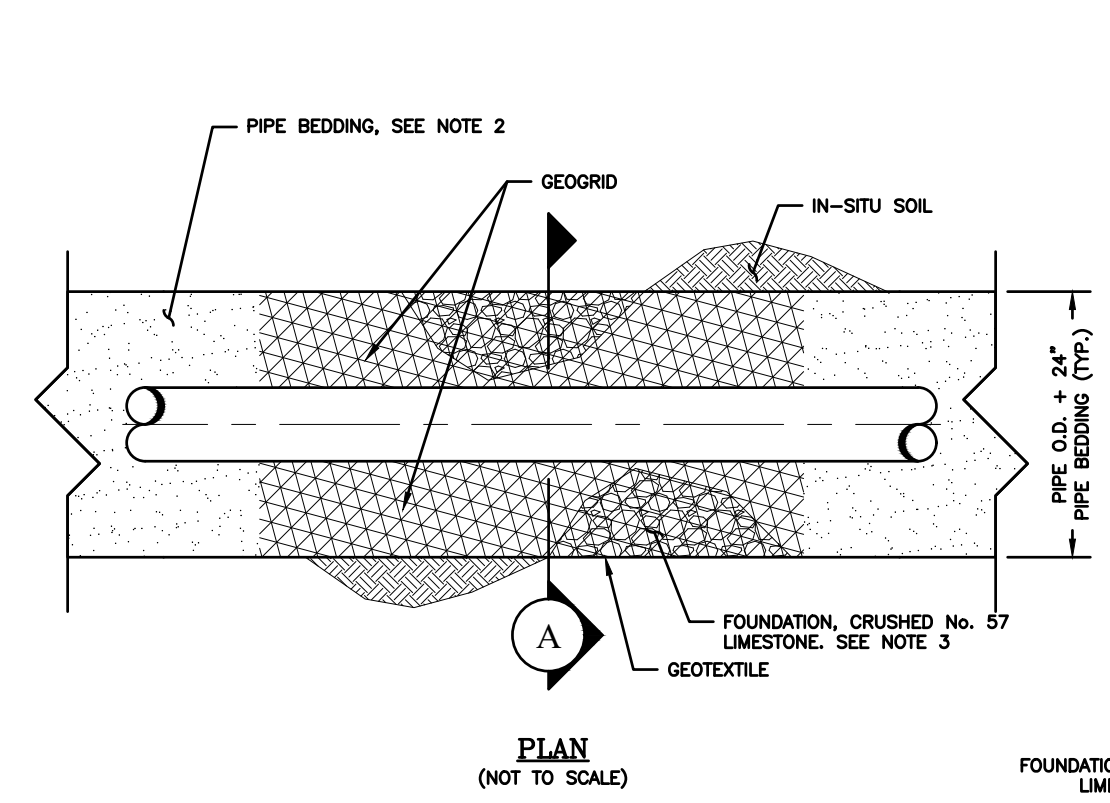

**TRENCH DETAIL**  
 (NOT TO SCALE)

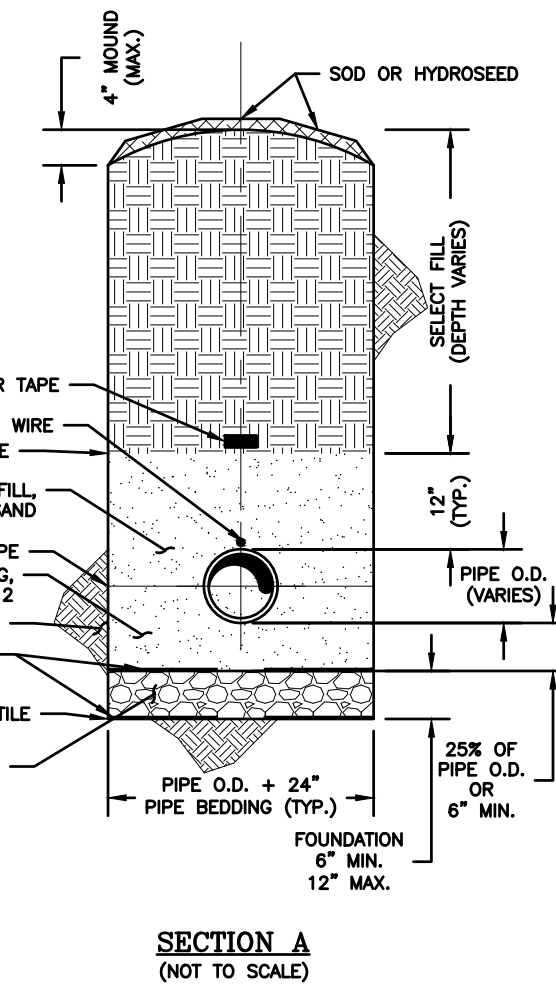

**SECTION A**  
 (NOT TO SCALE)

- TRENCH DETAIL NOTES:**
1. SELECT FILL SHALL BE A SILTY OR CLAYEY SAND COMPLYING WITH AASHTO GROUP CLASSIFICATION A-2-4. IN-SITU SOILS USED AS SELECT FILL SHALL MEET AASHTO GROUP CLASSIFICATION A-2-4 AND SHALL BE FREE OF LARGE DEBRIS, LARGE ROCKS, ROOTS, AND OTHER DELETERIOUS MATERIALS. SELECT FILL SHALL HAVE MINIMUM COMPACTION OF 95% OF THE MAXIMUM DRY UNIT WEIGHT AS DETERMINED BY ASTM D698.
  2. BEDDING MATERIALS FOR GRAVITY SEWER AND SEWER FORCE MAINS SHALL BE A CLEAN SAND COMPLYING WITH AASHTO GROUP CLASSIFICATION A-3. ALL BEDDING MATERIALS SHALL BE PLACED IN LOOSE LIFTS NOT EXCEEDING A THICKNESS OF EIGHT INCHES (8") PER LIFT. SANDY BEDDING MATERIALS SHALL HAVE MINIMUM COMPACTION OF 95% OF THE MAXIMUM DRY UNIT WEIGHT AS DETERMINED BY ASTM D698.
  3. A CRUSHED No. 57 LIMESTONE FOUNDATION SHALL BE USED TO STABILIZE SOFT AND/OR WET BOTTOM OF EXCAVATION. A MINIMUM OF 6 INCHES OF SOFT AND/OR WET NATIVE MATERIAL SHALL BE REMOVED PRIOR TO PLACING THE CRUSHED LIMESTONE FOUNDATION. CRUSHED No. 57 LIMESTONE SHALL BE PLACED IN LOOSE LIFTS NOT EXCEEDING A THICKNESS OF EIGHT INCHES (8") PER LIFT. CRUSHED LIMESTONE FOUNDATION SHALL HAVE MINIMUM COMPACTION OF 90% OF THE MAXIMUM DRY UNIT WEIGHT AS DETERMINED BY ASTM D4253.
  4. THE PLACEMENT OF GEOGRID SHALL BE AS SHOWN ON THE DETAIL. ALL GEOGRID SHALL BE A BIAXIAL GEOGRID SUCH AS TENSAR BXT200, SYNTEX SBR12 OR APPROVED EQUAL. TRANSVERSE AND LONGITUDINAL OVERLAP SHALL BE A MINIMUM OF 24 INCHES.
  5. THE PLACEMENT OF GEOTEXTILE FABRIC SHALL BE AS SHOWN ON THE DETAIL. GEOTEXTILE FABRIC SHALL BE MIRAFI 500X, PROPEX GEOTEXT 200ST OR APPROVED EQUAL. TRANSVERSE AND LONGITUDINAL OVERLAP SHALL BE A MINIMUM OF 24 INCHES.
  6. CONCRETE THRUST BLOCK SHALL HAVE A MINIMUM 28-DAY COMPRESSIVE STRENGTH OF 3,000 PSI.

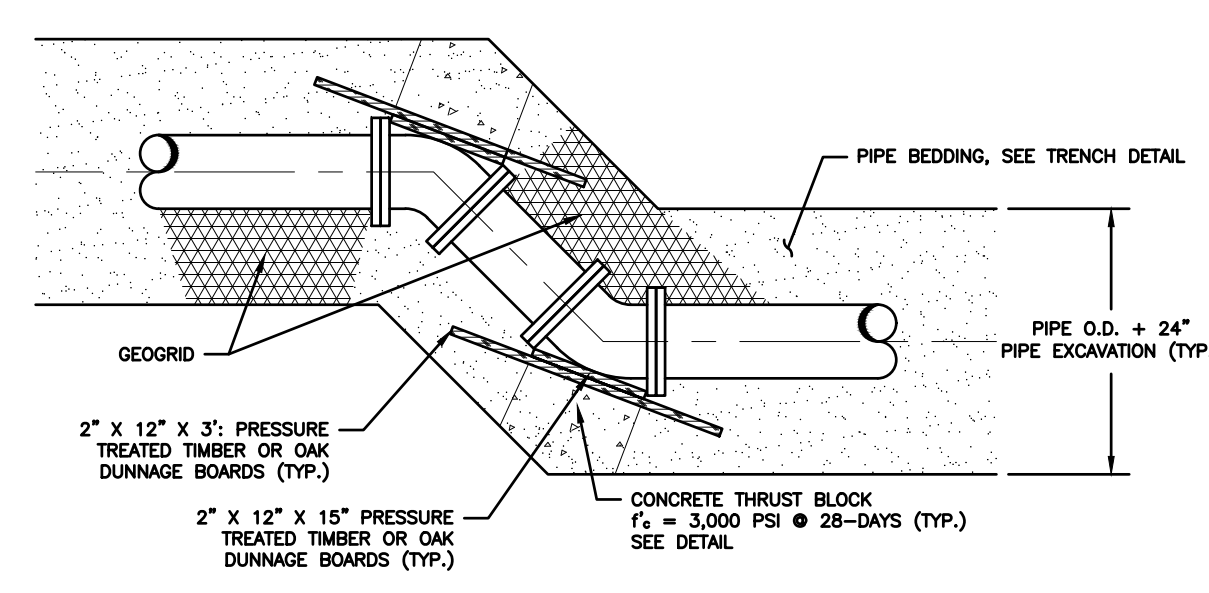

**THRUST BLOCK DETAILS FOR BENDS**  
 (NOT TO SCALE)

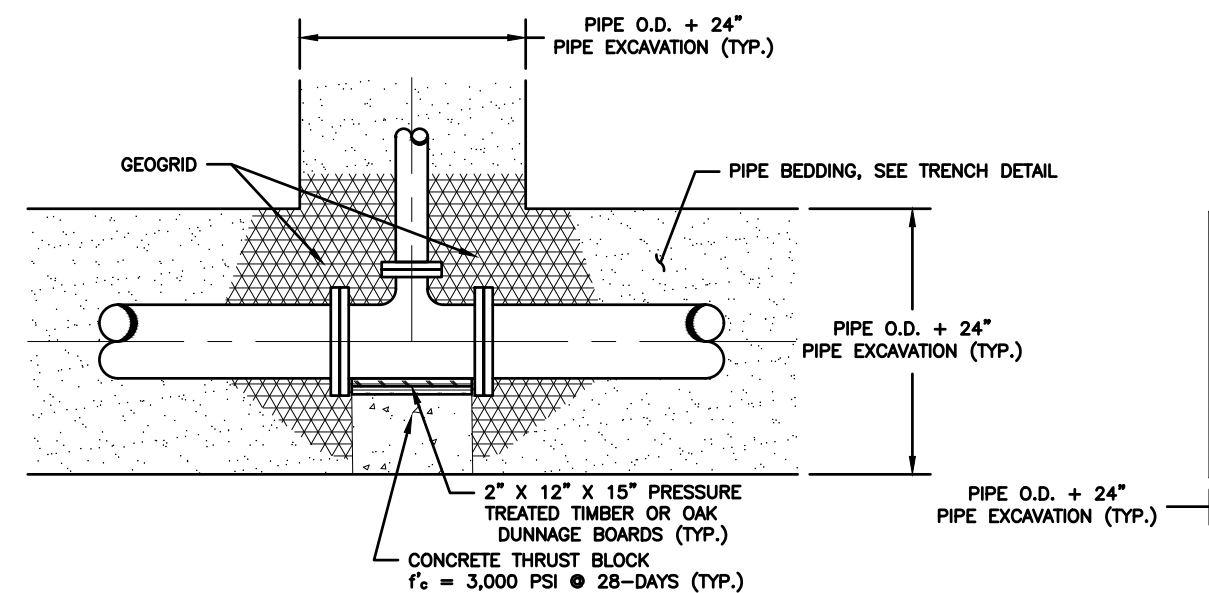

**THRUST BLOCK DETAILS FOR TEES**  
 (NOT TO SCALE)

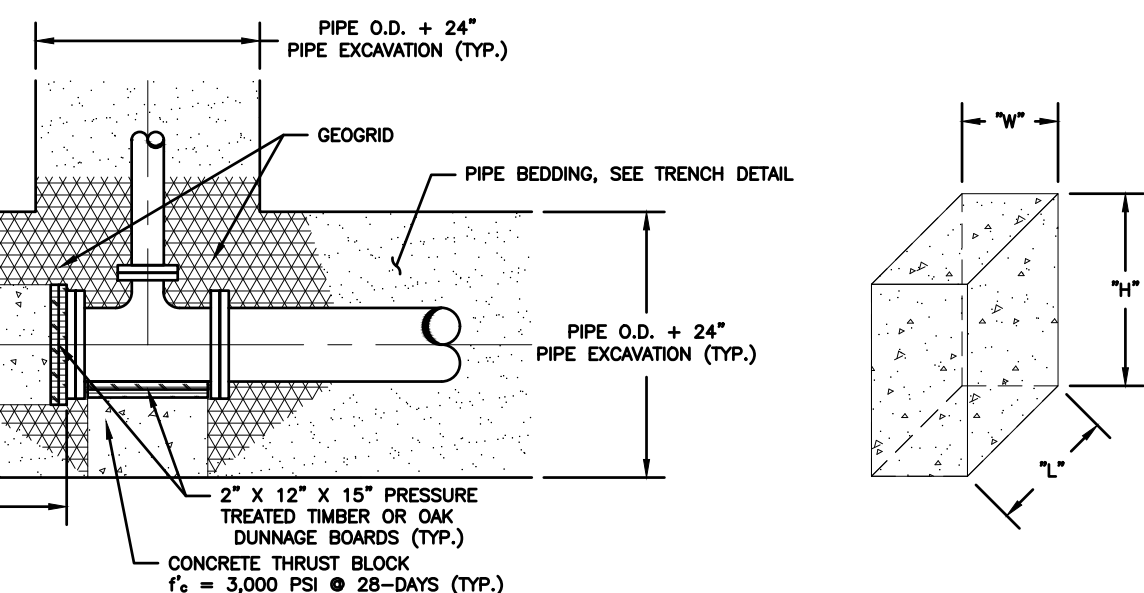

**THRUST BLOCK DETAILS FOR TEES AND PLUGS**  
 (NOT TO SCALE)

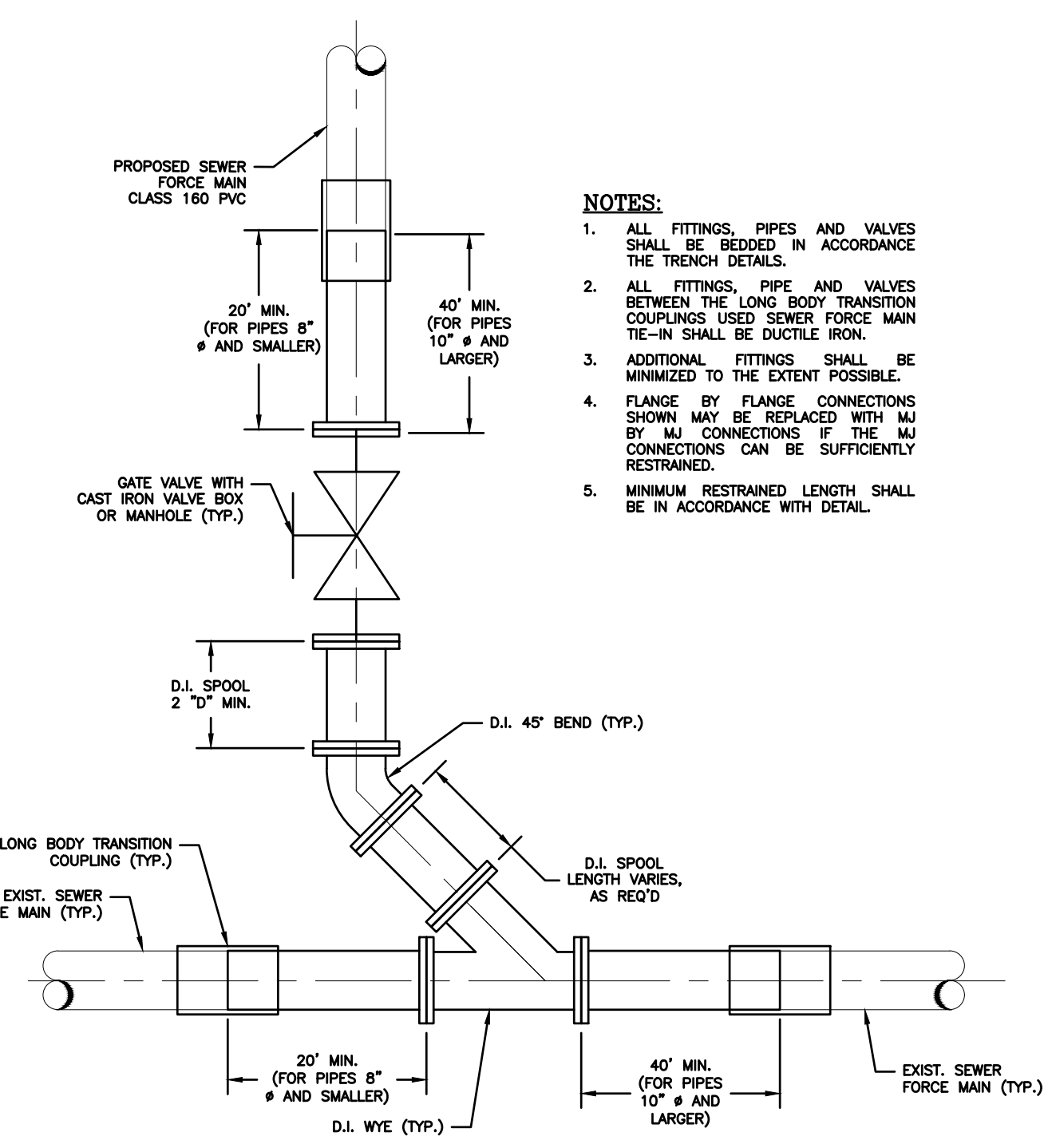

**TYPICAL SEWER FORCE MAIN TIE-IN DETAIL**  
 (NOT TO SCALE)

- NOTES:**
1. ALL FITTINGS, PIPES AND VALVES SHALL BE BEDDED IN ACCORDANCE WITH THE TRENCH DETAILS.
  2. ALL FITTINGS, PIPE AND VALVES BETWEEN THE LONG BODY TRANSITION COUPLINGS USED SEWER FORCE MAIN TIE-IN SHALL BE DUCTILE IRON.
  3. ADDITIONAL FITTINGS SHALL BE MINIMIZED TO THE EXTENT POSSIBLE.
  4. FLANGE BY FLANGE CONNECTIONS SHOWN MAY BE REPLACED WITH MJ BY MJ CONNECTIONS IF THE MJ CONNECTIONS CAN BE SUFFICIENTLY RESTRAINED.
  5. MINIMUM RESTRAINED LENGTH SHALL BE IN ACCORDANCE WITH DETAIL.

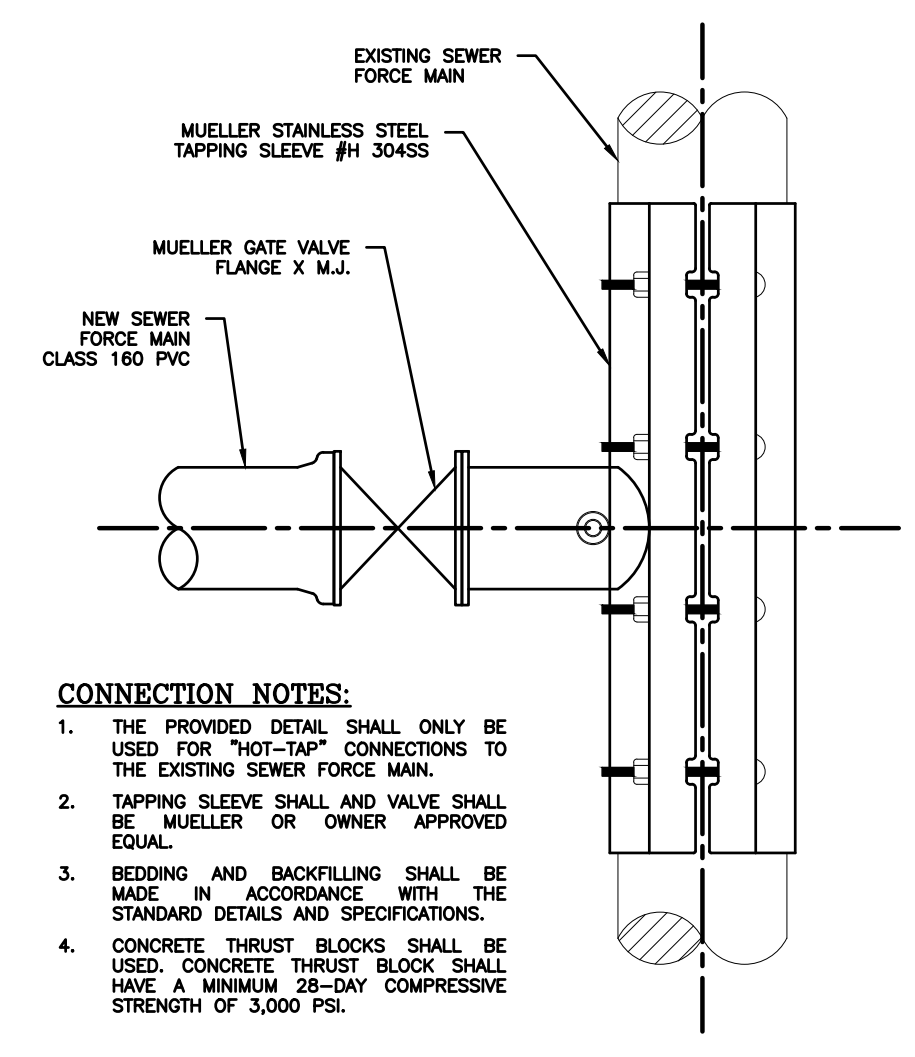

**NEW FORCE MAIN CONNECTION TO EXISTING FORCE MAIN DETAIL**  
 (NOT TO SCALE)

- CONNECTION NOTES:**
1. THE PROVIDED DETAIL SHALL ONLY BE USED FOR "HOT-TAP" CONNECTIONS TO THE EXISTING SEWER FORCE MAIN.
  2. TAPPING SLEEVE SHALL AND VALVE SHALL BE MUELLER OR OWNER APPROVED EQUAL.
  3. BEDDING AND BACKFILLING SHALL BE MADE IN ACCORDANCE WITH THE STANDARD DETAILS AND SPECIFICATIONS.
  4. CONCRETE THRUST BLOCKS SHALL BE USED. CONCRETE THRUST BLOCK SHALL HAVE A MINIMUM 28-DAY COMPRESSIVE STRENGTH OF 3,000 PSI.

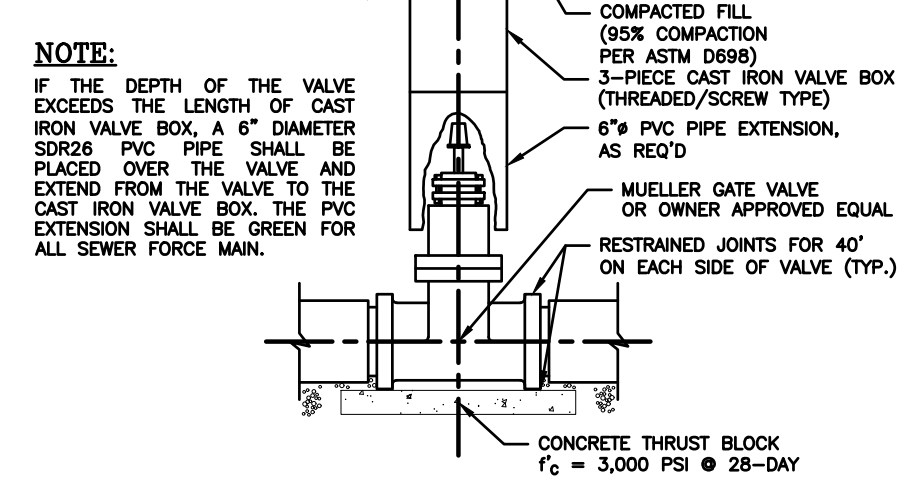

**VALVE BOX FOR NON-TRAFFIC AREAS**  
 (NOT TO SCALE)

- NOTE:**
- IF THE DEPTH OF THE VALVE EXCEEDS THE LENGTH OF CAST IRON VALVE BOX, A 6" DIAMETER SDR26 PVC PIPE SHALL BE PLACED OVER THE VALVE AND EXTEND FROM THE VALVE TO THE CAST IRON VALVE BOX. THE PVC EXTENSION SHALL BE GREEN FOR ALL SEWER FORCE MAIN.

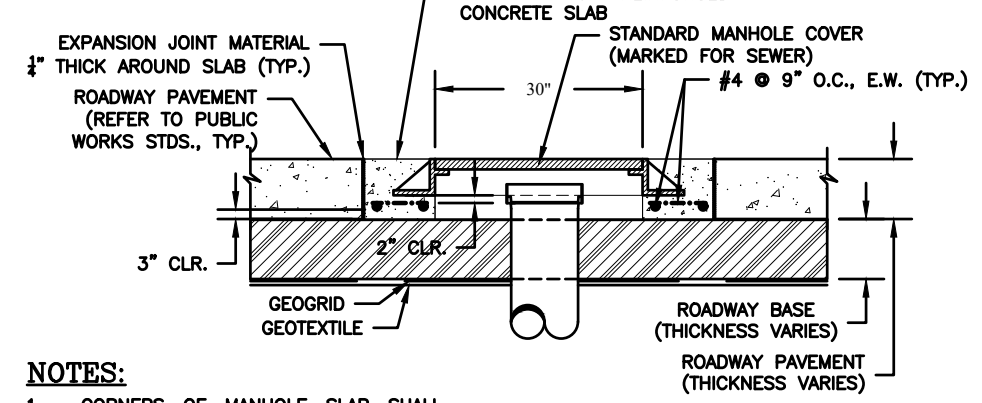

**SEWER VALVE BOX MANHOLE COVER FOR TRAFFIC AREAS**  
 (NOT TO SCALE)

- NOTES:**
1. CORNERS OF MANHOLE SLAB SHALL BE ALIGNED WITH PAVEMENT JOINTS FOR ALL STREET CONSISTING OF PORTLAND CEMENT CONCRETE PAVEMENT.

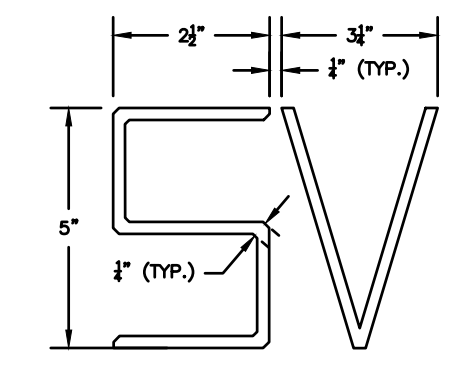

**SEWER FORCE MAIN VALVE PAVEMENT STAMP DETAIL**  
 (NOT TO SCALE)

**UNDER PAVEMENT TRENCH DETAIL NOTES:**

1. ROADS, CURBS, DRIVEWAY APRONS AND SIDEWALKS TO BE IMPACTED BY EXCAVATION FOR SEWER OR WATER LINE REPAIRS SHALL BE REMOVED AND REPLACED TO NEAREST JOINT. WHEN THE SEWER OR WATER LINE WILL BE REPAIRED UNDER ASPHALT PAVEMENT, THE ASPHALTIC CONCRETE PAVEMENT SHALL BE SAW CUT BEFORE TEARING OUT PAVEMENT.
2. ASPHALTIC CONCRETE PAVEMENT, BASE COURSE AND PORTLAND CEMENT CONCRETE PAVEMENT SHALL COMPLY WITH THE CURRENT VERSION OF THE STANDARD PLANS AND SPECIFICATIONS PROMULGATED BY THE LOUISIANA DEPARTMENT OF TRANSPORTATION AND DEVELOPMENT.
3. PORTLAND CEMENT CONCRETE PAVEMENT USED FOR ROADWAYS SHALL HAVE A MINIMUM 3-DAY COMPRESSIVE STRENGTH OF 4,000 PSI.
4. GRANULAR BACKFILL SHALL BE CLEAN SAND COMPLYING WITH AASHTO GROUP CLASSIFICATION A-3. GRANULAR BACKFILL SHALL BE PLACED IN LOOSE LIFTS NOT EXCEEDING A THICKNESS OF EIGHT INCHES (8") PER LIFT. GRANULAR BACKFILL SHALL HAVE MINIMUM COMPACTION OF 95% OF THE MAXIMUM DRY UNIT WEIGHT AS DETERMINED BY ASTM D698.
5. BEDDING MATERIALS FOR GRAVITY SEWER AND SEWER FORCE MAINS SHALL BE A CLEAN SAND COMPLYING WITH AASHTO GROUP CLASSIFICATION A-3. ALL BEDDING MATERIALS SHALL BE PLACED IN LOOSE LIFTS NOT EXCEEDING A THICKNESS OF EIGHT INCHES (8") PER LIFT. SANDY BEDDING MATERIALS SHALL HAVE MINIMUM COMPACTION OF 95% OF THE MAXIMUM DRY UNIT WEIGHT AS DETERMINED BY ASTM D698.
6. A CRUSHED No. 57 LIMESTONE FOUNDATION SHALL BE USED TO STABILIZE SOFT AND/OR WET BOTTOM OF EXCAVATION. A MINIMUM OF 6 INCHES OF SOFT AND/OR WET NATIVE MATERIAL SHALL BE REMOVED PRIOR TO PLACING THE CRUSHED LIMESTONE FOUNDATION. CRUSHED No. 57 LIMESTONE SHALL BE PLACED IN LOOSE LIFTS NOT EXCEEDING A THICKNESS OF EIGHT INCHES (8") PER LIFT. CRUSHED LIMESTONE FOUNDATION SHALL HAVE MINIMUM COMPACTION OF 90% OF THE MAXIMUM DRY UNIT WEIGHT AS DETERMINED BY ASTM D4253.
7. THE PLACEMENT OF GEOGRID SHALL BE AS SHOWN ON THE DETAIL. ALL GEOGRID SHALL BE A BIAXIAL GEOGRID SUCH AS TENSAR BXT200, SYNTEX SBR12 OR APPROVED EQUAL. TRANSVERSE AND LONGITUDINAL OVERLAP SHALL BE A MINIMUM OF 24 INCHES.
8. THE PLACEMENT OF GEOTEXTILE FABRIC SHALL BE AS SHOWN ON THE DETAIL. GEOTEXTILE FABRIC SHALL BE MIRAFI 500X, PROPEX GEOTEXT 200ST OR APPROVED EQUAL. TRANSVERSE AND LONGITUDINAL OVERLAP SHALL BE A MINIMUM OF 24 INCHES.
9. CONCRETE THRUST BLOCK SHALL HAVE A MINIMUM 28-DAY COMPRESSIVE STRENGTH OF 3,000 PSI.

FITTING TYPE	MINIMUM THRUST BLOCK SIZES BY FITTING TYPE		
	DIMENSION "M"	DIMENSION "N"	DIMENSION "L"
11.25"	6" MIN. OR 3 "D" / 2	2 "D" + PIPE O.D.	"D" MIN.
22.5"	6" MIN. OR 3 "D" / 2	2 "D" + PIPE O.D.	"D" MIN.
45"	6" MIN. OR 3 "D" / 2	2 "D" + PIPE O.D.	2 "D" MIN.
90"	6" + 2 "D"	2 "D" + PIPE O.D.	3 "D" MIN.
TEE	6" MIN. OR 3 "D" / 2	2 "D" + PIPE O.D.	2 "D" MIN.
WYE	6" MIN. OR 3 "D" / 2	2 "D" + PIPE O.D.	2 "D" MIN.
PLUG	6" MIN. OR 3 "D" / 2	3 "D"	3 "D"



# Section 16

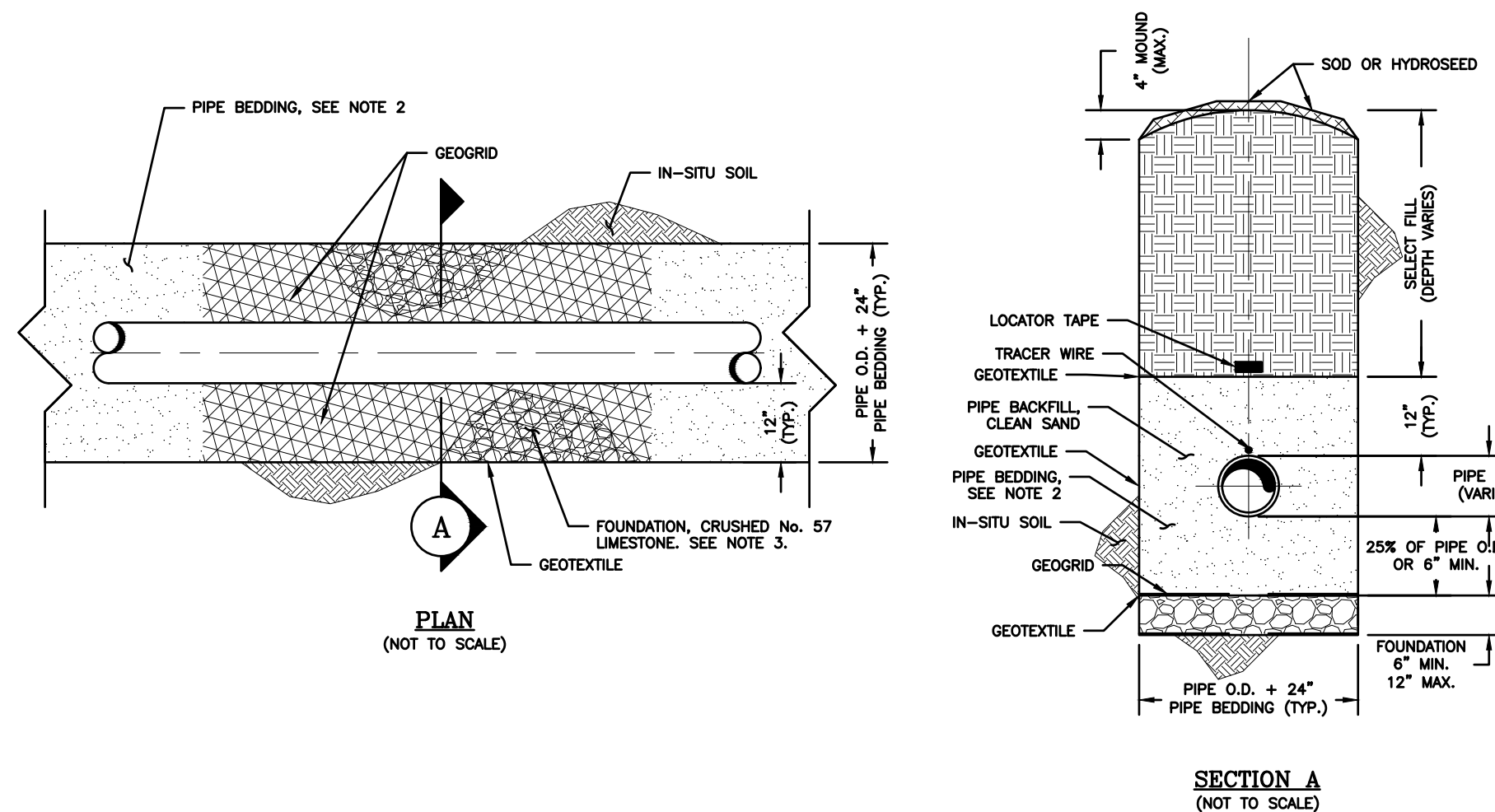

- TRENCH DETAIL NOTES:**
1. SELECT FILL SHALL BE A SILTY OR CLAYEY SAND COMPLYING WITH ASHTO GROUP CLASSIFICATION A-2-4. IN-SITU SOILS USED AS SELECT FILL SHALL MEET ASHTO GROUP CLASSIFICATION A-2-4 AND SHALL BE FREE OF LARGE DEBRIS, LARGE ROCKS, ROOTS, AND OTHER DELETERIOUS MATERIALS. SELECT FILL SHALL HAVE MINIMUM COMPACTION OF 95% OF THE MAXIMUM DRY UNIT WEIGHT AS DETERMINED BY ASTM D698.
  2. BEDDING MATERIALS FOR WATER LINES SHALL BE A CLEAN SAND COMPLYING WITH ASHTO GROUP CLASSIFICATION A-3. ALL BEDDING MATERIALS SHALL BE PLACED IN LOOSE LIFTS NOT EXCEEDING A THICKNESS OF EIGHT INCHES (8") PER LIFT. SANDY BEDDING MATERIALS SHALL HAVE MINIMUM COMPACTION OF 90% OF THE MAXIMUM DRY UNIT WEIGHT AS DETERMINED BY ASTM D698.
  3. A CRUSHED No. 57 LIMESTONE FOUNDATION SHALL BE USED TO STABILIZE SOFT AND/OR WET BOTTOM OF EXCAVATION. A MINIMUM OF 6 INCHES OF SOFT AND/OR WET NATIVE MATERIAL SHALL BE REMOVED PRIOR TO PLACING THE CRUSHED LIMESTONE FOUNDATION. CRUSHED No. 57 LIMESTONE SHALL BE PLACED IN LOOSE LIFTS NOT EXCEEDING A THICKNESS OF EIGHT INCHES (8") PER LIFT. CRUSHED LIMESTONE FOUNDATION SHALL HAVE MINIMUM COMPACTION OF 90% OF THE MAXIMUM DRY UNIT WEIGHT AS DETERMINED BY ASTM D4253.
  4. THE PLACEMENT OF GEOGRID SHALL BE AS SHOWN ON THE DETAIL. ALL GEOGRID SHALL BE A BAKUL GEOGRID SUCH AS TENSAR BX1200, SYNTAC SBX12 OR APPROVED EQUAL. TRANSVERSE AND LONGITUDINAL OVERLAP SHALL BE A MINIMUM OF 24 INCHES.
  5. THE PLACEMENT OF GEOTEXTILE FABRIC SHALL BE AS SHOWN ON THE DETAIL. GEOTEXTILE FABRIC SHALL BE MIRAFI SOOZ, PROPER GEOTEXT 200ST OR APPROVED EQUAL. TRANSVERSE AND LONGITUDINAL OVERLAP SHALL BE A MINIMUM OF 24 INCHES.
  6. CONCRETE THRUST BLOCK SHALL HAVE A MINIMUM 28-DAY COMPRESSIVE STRENGTH OF 3,000 PSI.

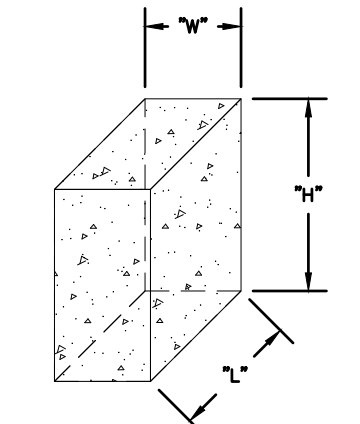
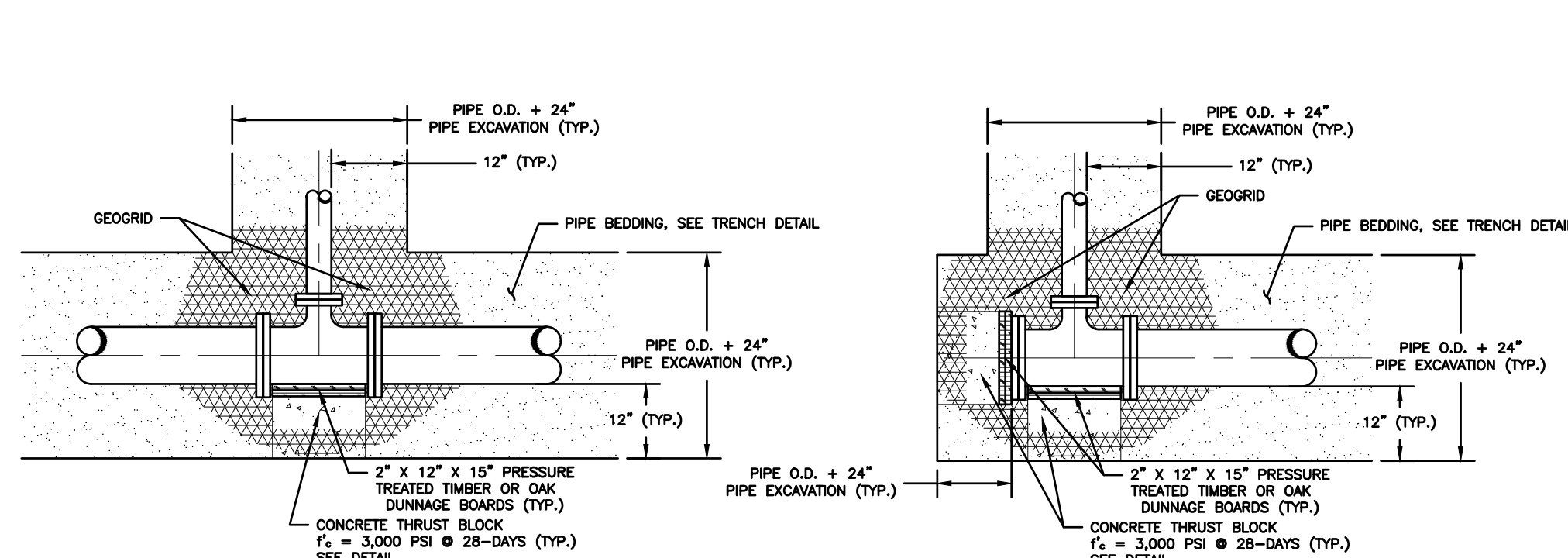
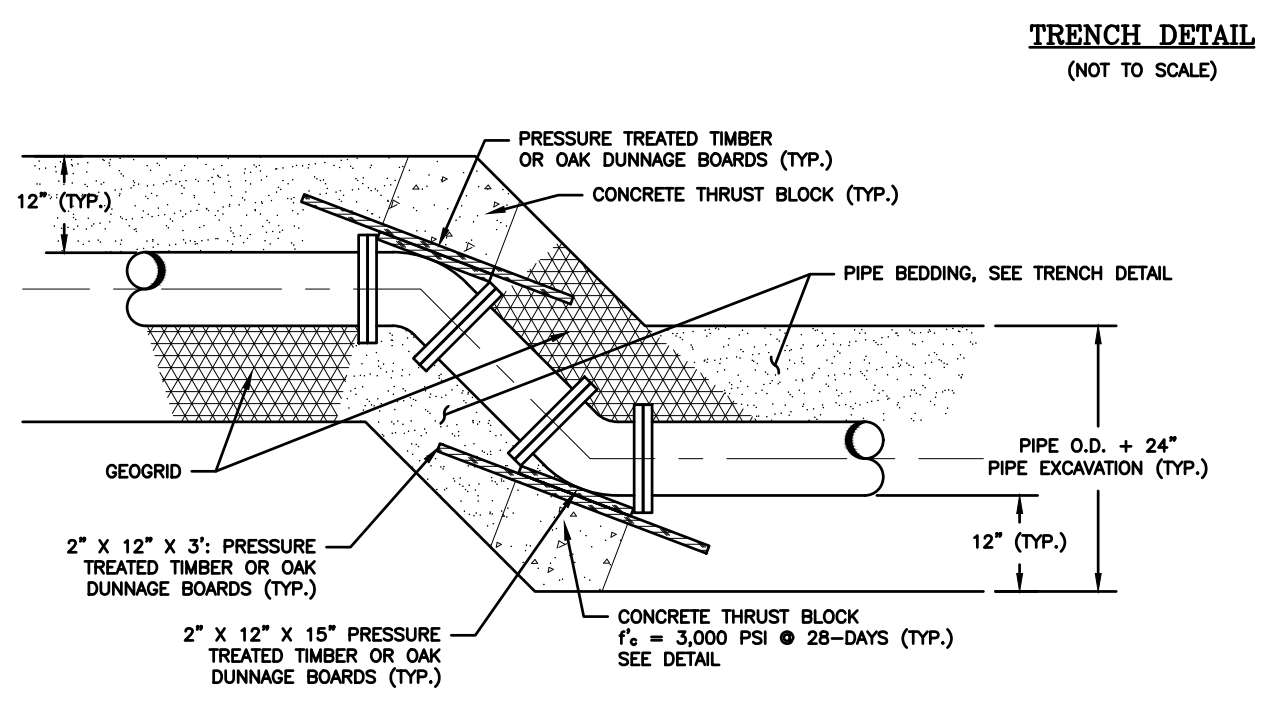

MINIMUM THRUST BLOCK SIZES BY FITTING TYPE			
FITTING TYPE	DIMENSION "W"	DIMENSION "H"	DIMENSION "L"
11.25"	6" MIN. OR 3 "D" / 2	2 "D" + PIPE O.D.	"D" MIN.
22.5"	6" MIN. OR 3 "D" / 2	2 "D" + PIPE O.D.	"D" MIN.
45"	6" MIN. OR 3 "D" / 2	2 "D" + PIPE O.D.	2 "D" MIN.
90"	6" + 2 "D"	2 "D" + PIPE O.D.	3 "D" MIN.
TEE	6" MIN. OR 3 "D" / 2	2 "D" + PIPE O.D.	2 "D" MIN.
WYE	6" MIN. OR 3 "D" / 2	2 "D" + PIPE O.D.	2 "D" MIN.
PLUG	6" MIN. OR 3 "D" / 2	3 "D"	3 "D"

NOTE:  
D = NOMINAL PIPE DIAMETER

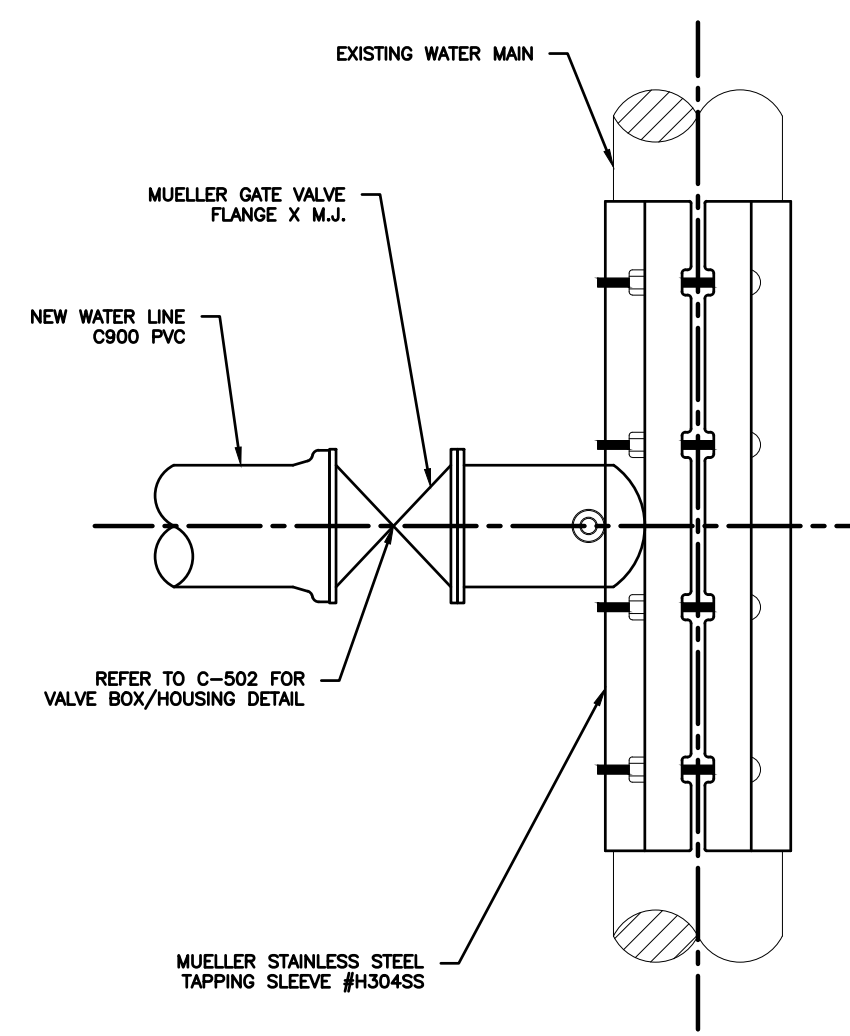
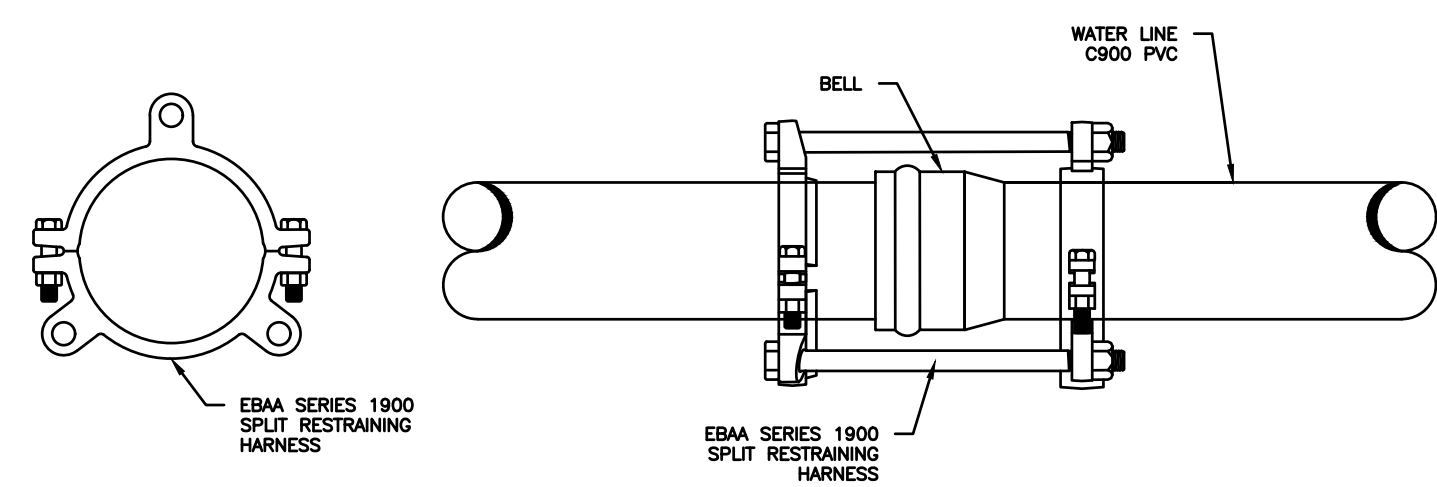
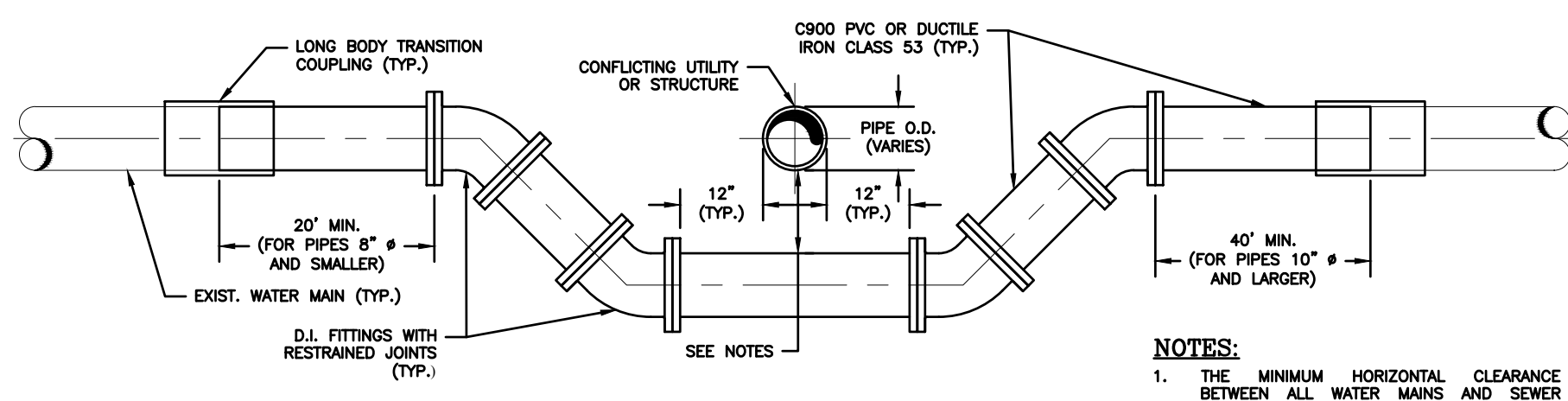

- CONNECTION NOTES:**
1. THE PROVIDED DETAIL SHALL ONLY BE USED FOR "HOT-TAP" CONNECTIONS TO THE EXISTING WATER MAIN.
  2. TAPPING SLEEVE AND VALVE SHALL BE MUELLER OR OWNER APPROVED EQUAL.
  3. BEDDING AND BACKFILLING SHALL BE MADE IN ACCORDANCE WITH THE STANDARD DETAILS AND SPECIFICATIONS.
  4. CONCRETE THRUST BLOCKS SHALL BE USED. CONCRETE THRUST BLOCK SHALL HAVE A MINIMUM 28-DAY COMPRESSIVE STRENGTH OF 3,000 PSI.
  5. VALVES SHALL NOT BE LOCATED IN THE DITCH SLOPE OR BOTTOM. FINAL LOCATION TO BE APPROVED BY ENGINEER PRIOR TO INSTALLATION.
  6. CONTRACTOR MUST NOTIFY DEPT. OF UTILITIES AT LEAST 72 HOURS PRIOR TO THE IN-ALL TIE-INS TO BE APPROVED AND OBSERVED BY DEPT. OF UTILITIES.

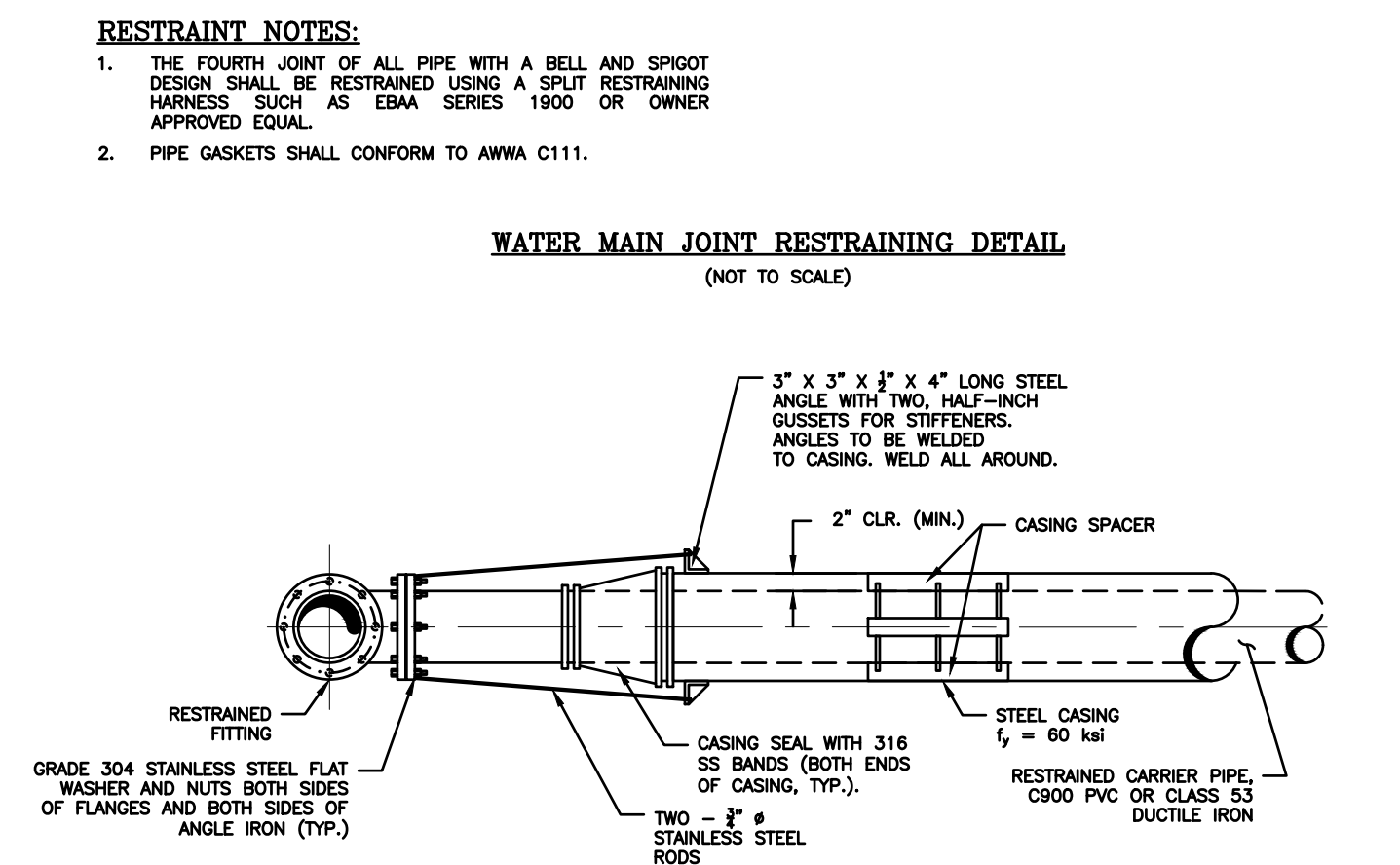
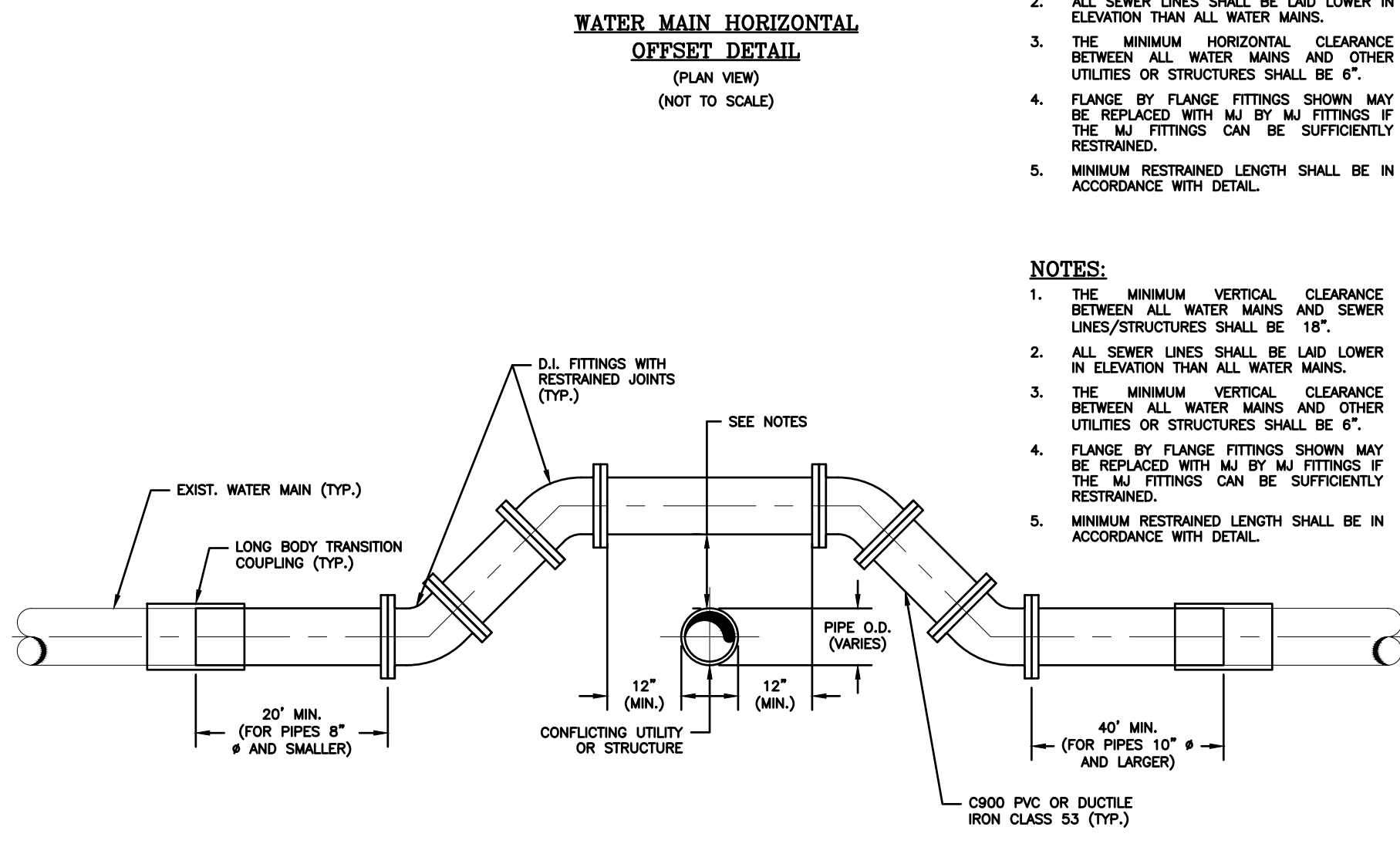

- NOTES:**
1. ALL CASING ENDS SHALL BE RESTRAINED TO THE NEAREST FITTING

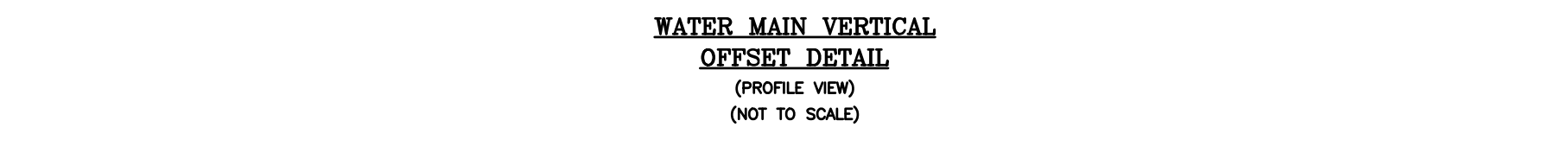

DATE:	DESCRIPTION OF REVISION
No.	

DESIGNED BY:	AH/CT
DRAWN BY:	AH
CHECKED BY:	BM/CT
APPROVED BY:	CT
ISSUE DATE:	03/2023
ISSUED BY:	UTILITIES
SHEET SIZE:	ANSI D
SCALE:	AS NOTED

DEPARTMENT OF UTILITIES  
ST. TAMMANY PARISH GOVERNMENT  
CONSTRUCTION STANDARDS FOR  
WATER DISTRIBUTION

WATER STANDARD DETAILS



DATE:	
DESCRIPTION OF REVISION:	
No.	

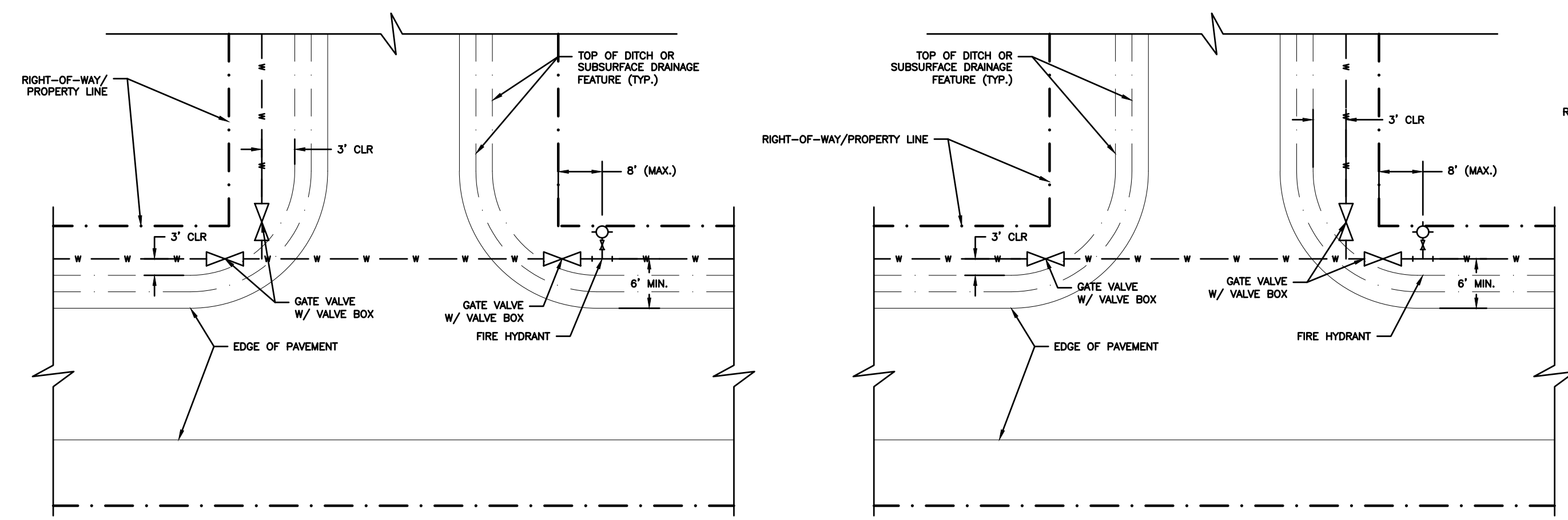

**TYPICAL FIRE HYDRANT AND VALVE LOCATIONS AT INTERSECTIONS**  
(NOT TO SCALE)



**TYPICAL UTILITY CROSS SECTION (WATER MAINS AND VALVES)**  
(NOT TO SCALE)

**NOTES:**  
1. REFER TO DEPT OF UTILITIES STANDARD DETAILS REGARDING LAYOUT OF WATER MAIN OFFSETS.  
2. REFER TO DEPT OF UTILITIES STANDARD NOTES FOR REQUIREMENT ON LOCATION OF WATER MAIN AND VALVES.

PIPE DIAMETER (IN.)	MINIMUM COVER (IN.)	BEDDING DEPTH (IN.)	BEDDING MATERIAL TYPE
12" AND SMALLER*	36"	25% PIPE O.D. OR 6" MIN.	CLEAN SAND
14" AND LARGER	48"	25% PIPE O.D. OR 6" MIN.	CLEAN SAND

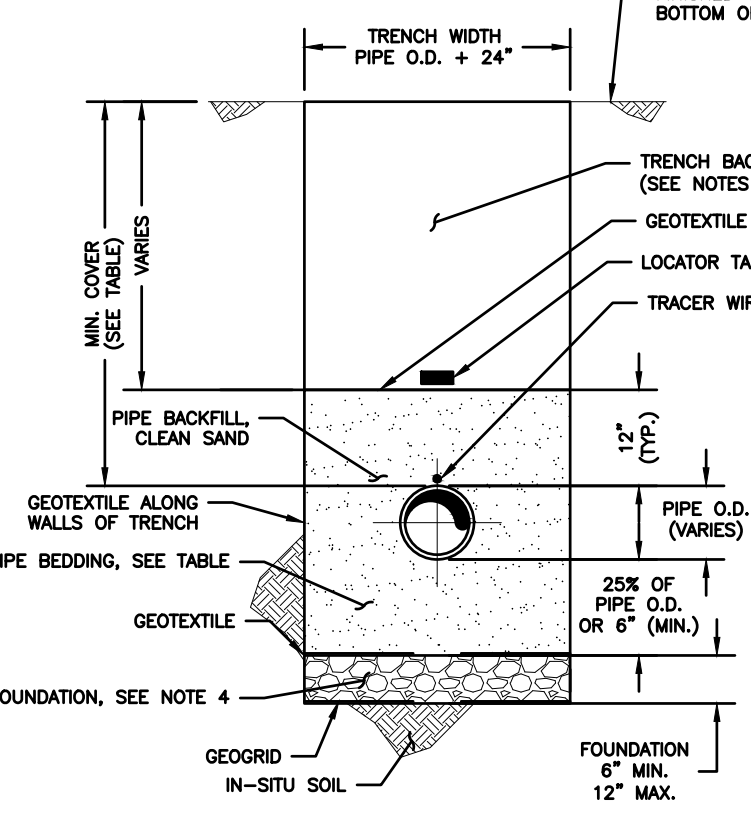

**BACKFILL DETAIL**  
(NOT TO SCALE)

- BACKFILL DETAIL NOTES:**
- BACKFILLING OF TRENCHES FOR UNPAVED AREAS SHALL BE COMPLETED USING SELECT FILL. SELECT FILL SHALL BE A SILTY OR CLAYEY SAND COMPLYING WITH ASHTO GROUP CLASSIFICATION A-2-4. IN-SITU SOILS USED AS SELECT FILL SHALL MEET ASHTO GROUP CLASSIFICATION A-2-4 AND SHALL BE FREE OF LARGE DEBRIS, LARGE ROCKS, ROOTS, AND OTHER DELETERIOUS MATERIALS. SELECT FILL SHALL HAVE MINIMUM COMPACTION OF 95% OF THE MAXIMUM DRY UNIT WEIGHT AS DETERMINED BY ASTM D698.
  - BACKFILLING OF TRENCHES FOR PAVED AREAS SHALL BE COMPLETED USING GRANULAR BACKFILL. GRANULAR BACKFILL SHALL BE CLEAN SAND COMPLYING WITH ASHTO GROUP CLASSIFICATION A-3. GRANULAR BACKFILL SHALL BE PLACED IN LOOSE LIFTS NOT EXCEEDING A THICKNESS OF EIGHT INCHES (8") PER LIFT. GRANULAR BACKFILL SHALL HAVE MINIMUM COMPACTION OF 95% OF THE MAXIMUM DRY UNIT WEIGHT AS DETERMINED BY ASTM D698.
  - BEDDING MATERIALS FOR WATER LINES SHALL BE A CLEAN SAND COMPLYING WITH ASHTO GROUP CLASSIFICATION A-3. ALL BEDDING MATERIALS SHALL BE PLACED IN LOOSE LIFTS NOT EXCEEDING A THICKNESS OF EIGHT INCHES (8") PER LIFT. SANDY BEDDING MATERIALS SHALL HAVE MINIMUM COMPACTION OF 95% OF THE MAXIMUM DRY UNIT WEIGHT AS DETERMINED BY ASTM D698.
  - A CRUSHED No. 57 LIMESTONE FOUNDATION SHALL BE USED TO STABILIZE SOFT AND/OR WET BOTTOM OF EXCAVATION. A MINIMUM OF 6 INCHES OF SOFT AND/OR WET NATIVE MATERIAL SHALL BE REMOVED PRIOR TO PLACING THE CRUSHED LIMESTONE FOUNDATION. CRUSHED No. 57 LIMESTONE SHALL BE PLACED IN LOOSE LIFTS NOT EXCEEDING A THICKNESS OF EIGHT INCHES (8") PER LIFT. CRUSHED LIMESTONE FOUNDATION SHALL HAVE MINIMUM COMPACTION OF 95% OF THE MAXIMUM DRY UNIT WEIGHT AS DETERMINED BY ASTM D4253.
  - THE PLACEMENT OF GEOTEXTILE SHALL BE AS SHOWN ON THE DETAIL. ALL GEOTEXTILE SHALL BE A BIAXIAL GEOTEXTILE SUCH AS TENSAR BX1200, SYNTEC SBX12 OR APPROVED EQUAL. TRANSVERSE AND LONGITUDINAL OVERLAP SHALL BE A MINIMUM OF 24 INCHES.
  - THE PLACEMENT OF GEOTEXTILE FABRIC SHALL BE AS SHOWN ON THE DETAIL. GEOTEXTILE FABRIC SHALL BE MIRAFI 500X, PROPEX GEOTEXT 200ST OR APPROVED EQUAL. TRANSVERSE AND LONGITUDINAL OVERLAP SHALL BE A MINIMUM OF 24 INCHES.

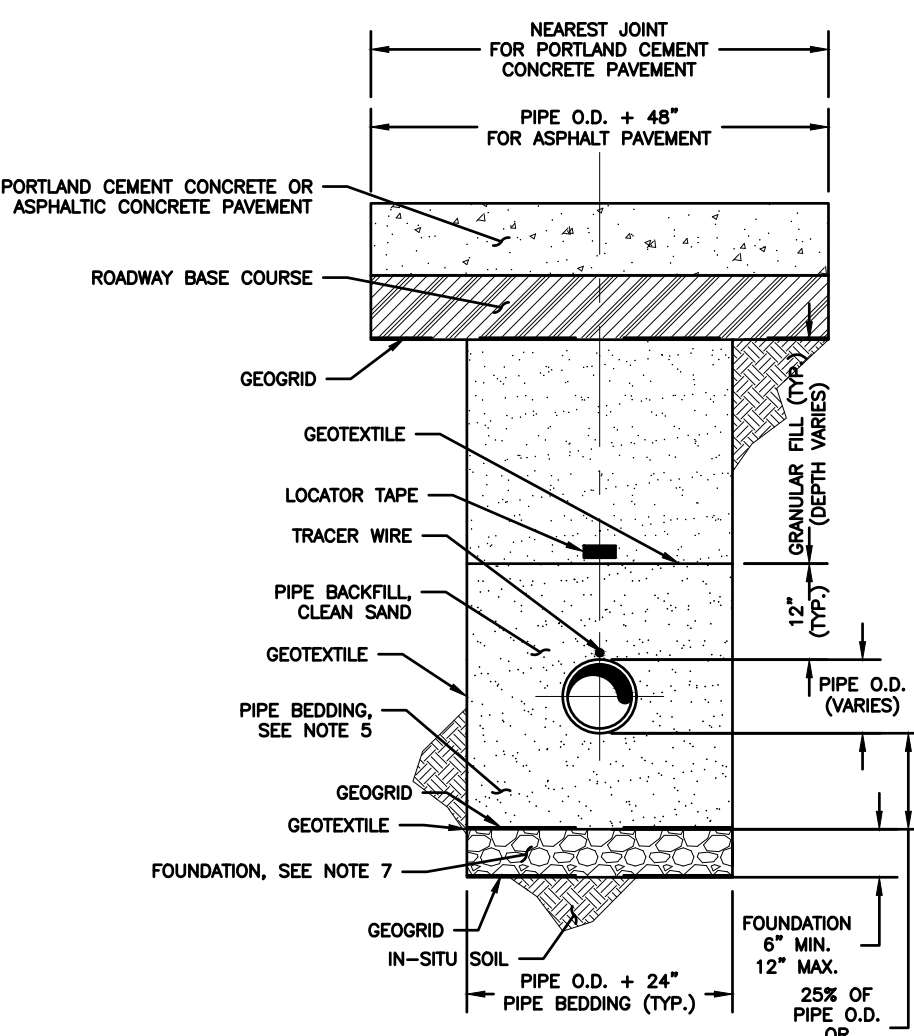

**UNDER PAVEMENT TRENCH DETAIL**  
(NOT TO SCALE)

- UNDER PAVEMENT TRENCH DETAIL NOTES:**
- ROADS, CURBS, DRIVEWAY APRONS AND SIDEWALKS TO BE IMPACTED BY EXCAVATION FOR SEWER OR WATER LINE REPAIRS SHALL BE REMOVED AND REPLACED TO NEAREST JOINT. WHEN THE SEWER OR WATER LINE WILL BE REPAIRED UNDER ASPHALT PAVEMENT, THE ASPHALT CONCRETE PAVEMENT SHALL BE SAW CUT BEFORE TEARING OUT PAVEMENT.
  - ASPHALTIC CONCRETE PAVEMENT, BASE COURSE AND PORTLAND CEMENT CONCRETE PAVEMENT SHALL COMPLY WITH THE MOST RECENT VERSION OF THE STANDARD PLANS AND SPECIFICATIONS PROMULGATED BY THE LOUISIANA DEPARTMENT OF TRANSPORTATION AND DEVELOPMENT.
  - PORTLAND CEMENT CONCRETE PAVEMENT USED FOR ROADWAYS SHALL HAVE A MINIMUM 3-DAY COMPRESSIVE STRENGTH OF 4,000 PSI.
  - GRANULAR BACKFILL SHALL BE CLEAN SAND COMPLYING WITH ASHTO GROUP CLASSIFICATION A-3. GRANULAR BACKFILL SHALL BE PLACED IN LOOSE LIFTS NOT EXCEEDING A THICKNESS OF EIGHT INCHES (8") PER LIFT. GRANULAR BACKFILL SHALL HAVE MINIMUM COMPACTION OF 95% OF THE MAXIMUM DRY UNIT WEIGHT AS DETERMINED BY ASTM D698.
  - BEDDING MATERIALS FOR WATER LINES SHALL BE A CLEAN SAND COMPLYING WITH ASHTO GROUP CLASSIFICATION A-3. ALL BEDDING MATERIALS SHALL BE PLACED IN LOOSE LIFTS NOT EXCEEDING A THICKNESS OF EIGHT INCHES (8") PER LIFT. SANDY BEDDING MATERIALS SHALL HAVE MINIMUM COMPACTION OF 95% OF THE MAXIMUM DRY UNIT WEIGHT AS DETERMINED BY ASTM D698.
  - A CRUSHED No. 57 LIMESTONE FOUNDATION SHALL BE USED TO STABILIZE SOFT AND/OR WET BOTTOM OF EXCAVATION. A MINIMUM OF 6 INCHES OF SOFT AND/OR WET NATIVE MATERIAL SHALL BE REMOVED PRIOR TO PLACING THE CRUSHED LIMESTONE FOUNDATION. CRUSHED No. 57 LIMESTONE SHALL BE PLACED IN LOOSE LIFTS NOT EXCEEDING A THICKNESS OF EIGHT INCHES (8") PER LIFT. CRUSHED LIMESTONE FOUNDATION SHALL HAVE MINIMUM COMPACTION OF 95% OF THE MAXIMUM DRY UNIT WEIGHT AS DETERMINED BY ASTM D4253.
  - THE PLACEMENT OF GEOTEXTILE SHALL BE AS SHOWN ON THE DETAIL. ALL GEOTEXTILE SHALL BE A BIAXIAL GEOTEXTILE SUCH AS TENSAR BX1200, SYNTEC SBX12 OR APPROVED EQUAL. TRANSVERSE AND LONGITUDINAL OVERLAP SHALL BE A MINIMUM OF 24 INCHES.
  - THE PLACEMENT OF GEOTEXTILE FABRIC SHALL BE AS SHOWN ON THE DETAIL. GEOTEXTILE FABRIC SHALL BE MIRAFI 500X, PROPEX GEOTEXT 200ST OR APPROVED EQUAL. TRANSVERSE AND LONGITUDINAL OVERLAP SHALL BE A MINIMUM OF 24 INCHES.
  - CONCRETE THRUST BLOCK SHALL HAVE A MINIMUM 28-DAY COMPRESSIVE STRENGTH OF 3,000 PSI.

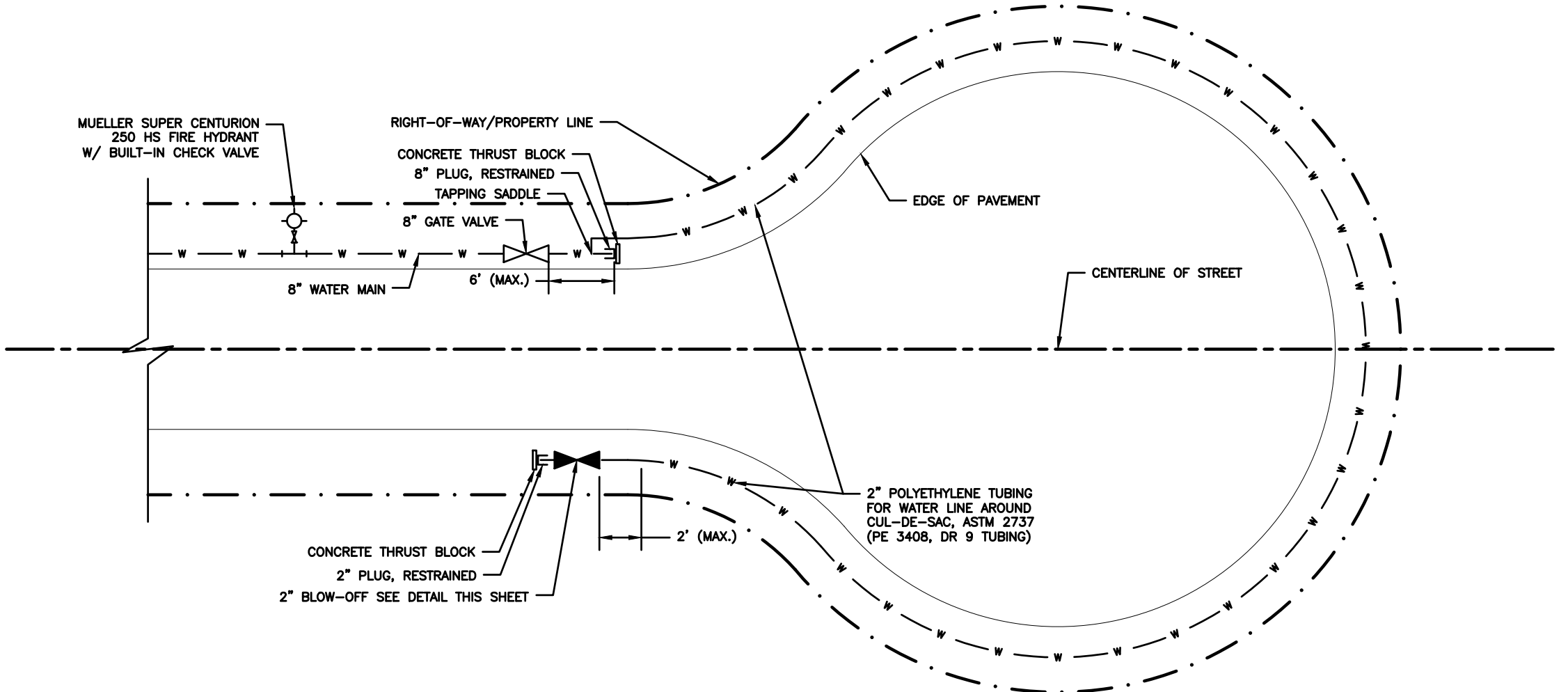

**CUL-DE-SAC DETAIL**  
(NOT TO SCALE)

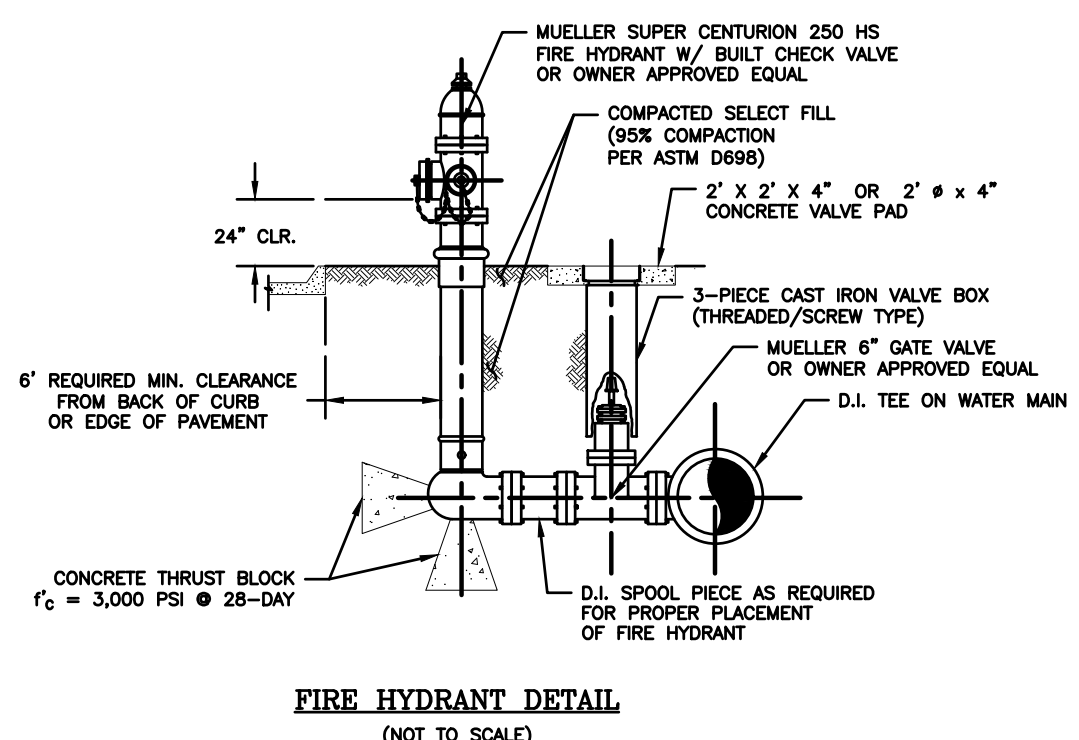

**FIRE HYDRANT DETAIL**  
(NOT TO SCALE)

- FIRE HYDRANT NOTES:**
- FIRE HYDRANTS SHALL BE MUELLER SUPER CENTURION 250 HS WITH BUILT-IN CHECK VALVE MEETING ANWA C-502.
  - SELECT FILL SHALL BE A SILTY OR CLAYEY SAND COMPLYING WITH ASHTO GROUP CLASSIFICATION A-2-4. IN-SITU SOILS USED AS SELECT FILL SHALL MEET ASHTO GROUP CLASSIFICATION A-2-4 AND SHALL BE FREE OF LARGE DEBRIS, LARGE ROCKS, ROOTS, AND OTHER DELETERIOUS MATERIALS. SELECT FILL SHALL HAVE MINIMUM COMPACTION OF 95% OF THE MAXIMUM DRY UNIT WEIGHT AS DETERMINED BY ASTM D698.
  - BEDDING MATERIALS FOR WATER LINES SHALL BE A CLEAN SAND COMPLYING WITH ASHTO GROUP CLASSIFICATION A-3. ALL BEDDING MATERIALS SHALL BE PLACED IN LOOSE LIFTS NOT EXCEEDING A THICKNESS OF EIGHT INCHES (8") PER LIFT. SANDY BEDDING MATERIALS SHALL HAVE MINIMUM COMPACTION OF 95% OF THE MAXIMUM DRY UNIT WEIGHT AS DETERMINED BY ASTM D698.
  - THE PLACEMENT OF GEOTEXTILE SHALL BE AS SHOWN ON THE TRENCH DETAILS. ALL GEOTEXTILE SHALL BE A BIAXIAL GEOTEXTILE SUCH AS TENSAR BX1200, SYNTEC SBX12 OR APPROVED EQUAL. TRANSVERSE AND LONGITUDINAL OVERLAP SHALL BE A MINIMUM OF 24 INCHES.
  - THE PLACEMENT OF GEOTEXTILE FABRIC SHALL BE AS SHOWN ON THE TRENCH DETAILS. GEOTEXTILE FABRIC SHALL BE MIRAFI 500X, PROPEX GEOTEXT 200ST OR APPROVED EQUAL. TRANSVERSE AND LONGITUDINAL OVERLAP SHALL BE A MINIMUM OF 24 INCHES.
  - CONCRETE THRUST BLOCK SHALL HAVE A MINIMUM 28-DAY COMPRESSIVE STRENGTH OF 3,000 PSI.

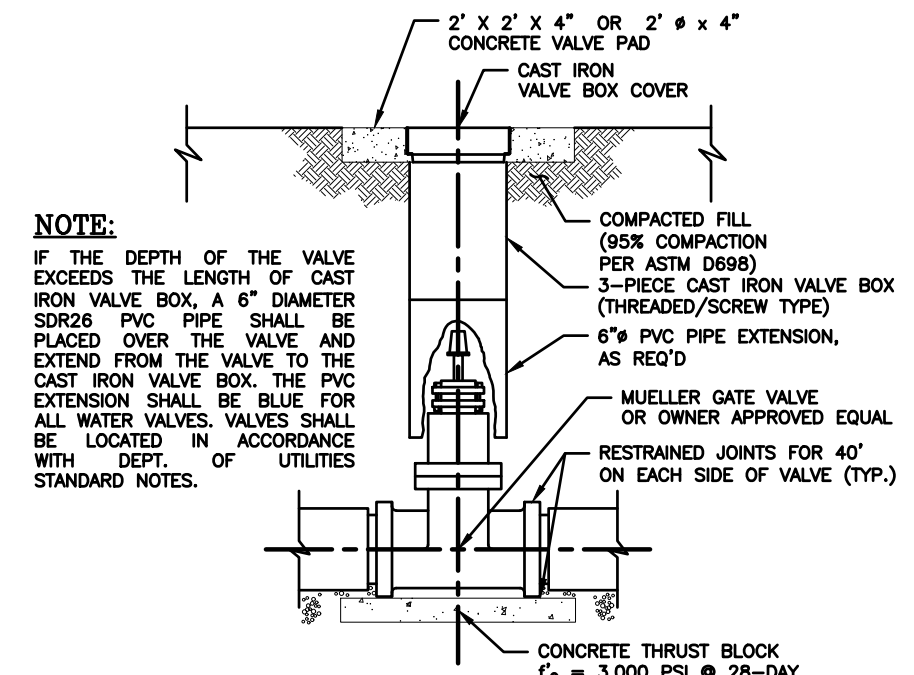

**VALVE BOX FOR NON-TRAFFIC AREAS**  
(NOT TO SCALE)

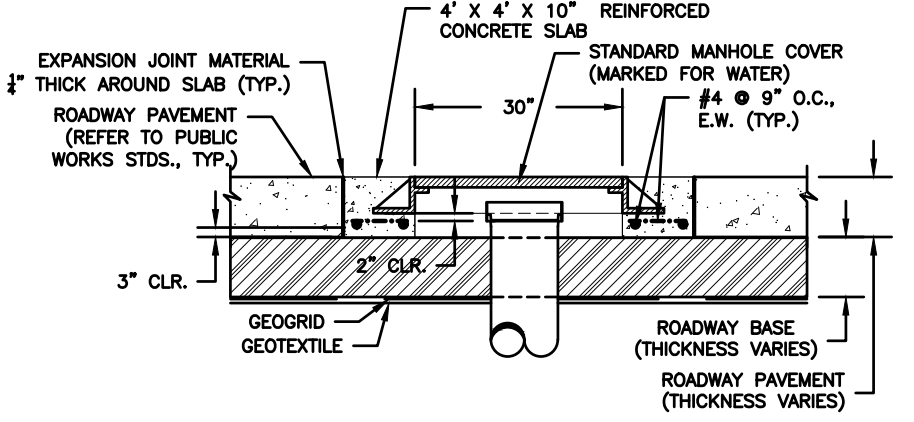

**WATER VALVE BOX MANHOLE COVER FOR TRAFFIC AREAS**  
(NOT TO SCALE)

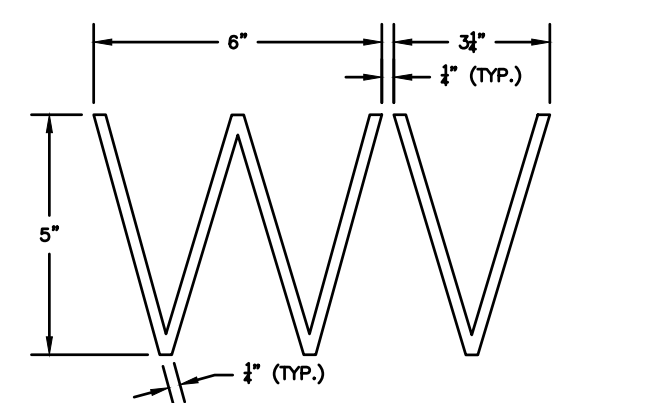

**WATER VALVE PAVEMENT STAMP DETAIL**  
(NOT TO SCALE)

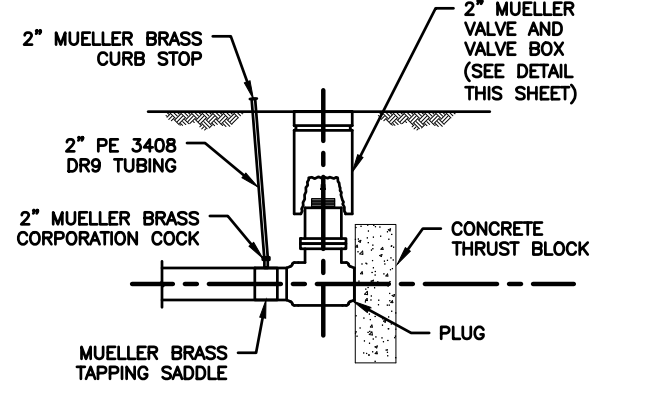

**BLOW VALVE DETAIL**  
(NOT TO SCALE)

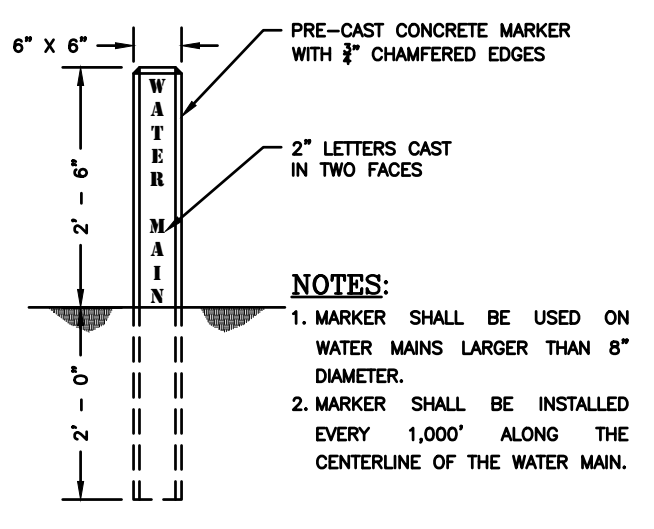

**WATER MAIN MARKER DETAIL**  
(NOT TO SCALE)



**WATER SERVICE PAVEMENT STAMP DETAIL**  
(NOT TO SCALE)

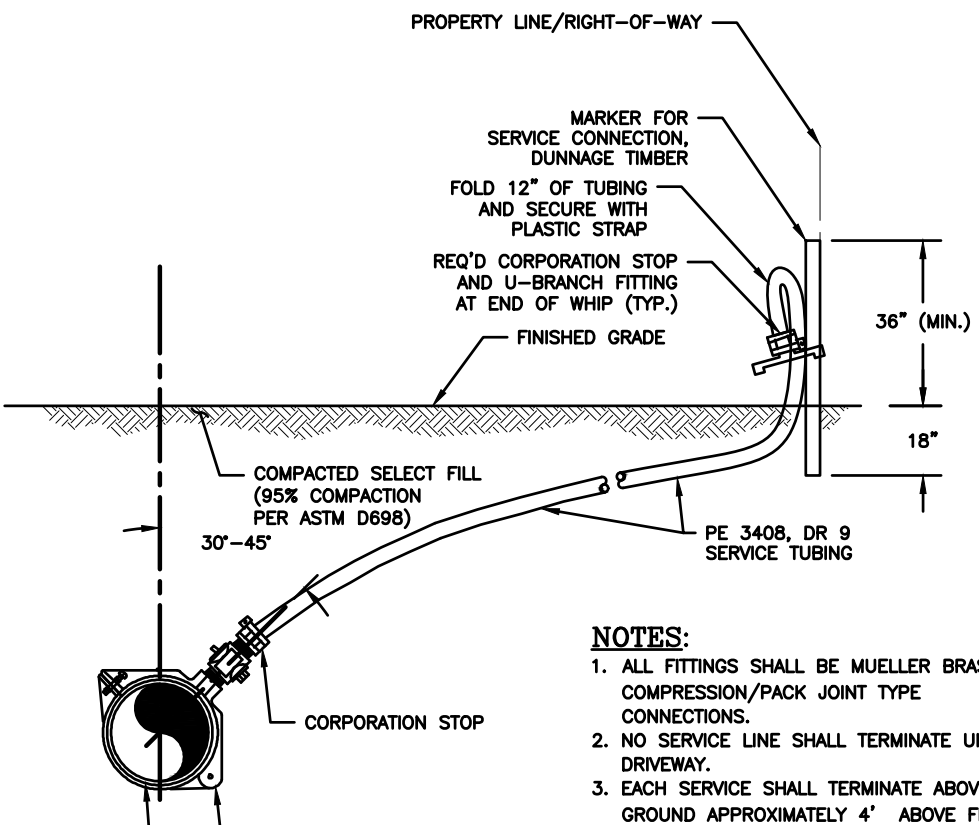

**WATER SERVICE CONNECTION DETAIL**  
(NOT TO SCALE)

- NOTES:**
- ALL FITTINGS SHALL BE MUELLER BRASS WITH COMPRESSION/PACK JOINT TYPE CONNECTIONS.
  - NO SERVICE LINE SHALL TERMINATE UNDER A DRIVEWAY.
  - EACH SERVICE SHALL TERMINATE ABOVE GROUND APPROXIMATELY 4' ABOVE FINAL GRADE.
  - ALL WATER SERVICES SHALL BE LOCATED INSIDE THE STREET RIGHT-OF-WAY LINE.
  - U-BRANCHES SHALL BE MUELLER BRAND OR FORD METER BOX CO BRAND. MODEL NUMBERS SHALL BE AS SHOWN ON SHEET 503.
  - CORPORATION STOPS AND U-BRANCHES SHALL BE INSTALLED AT THE END OF ALL WATER SERVICES.

DESIGNED BY:	AH/CT
DRAWN BY:	AH
CHECKED BY:	BM/CT
APPROVED BY:	CT
DEPT. OF UTILITIES	
ST. TAMMANY PARISH GOVERNMENT	
620 N. TYLER STREET	
COVINGTON, LA 70433	
ISSUE DATE:	03/2023
ISSUED BY:	UTILITIES
SHEET SIZE:	ANSI D
SCALE:	AS NOTED

DEPARTMENT OF UTILITIES  
ST. TAMMANY PARISH GOVERNMENT  
CONSTRUCTION STANDARDS FOR  
WATER DISTRIBUTION



DEPARTMENT OF UTILITIES APPROVED FITTINGS FOR WATER			
CATEGORY	ITEM	APPROVED MANUFACTURER	MODEL/PART No.
COMPRESSION FITTING	1" X 3/4" 7.5" U-BRANCH	MUELLER	MH1460NGFWD
COMPRESSION FITTING	2" CORP STOP IPT THREAD	MUELLER	MH15023NK
		FORD METER BOX CO.	FB11007NL
COMPRESSION FITTING	1" CC X CTS COMP CORP STOP	MUELLER	MH15008NG
		FORD METER BOX CO.	FF10004NL
COMPRESSION FITTING	2" MIP X CTS CORP STOP	MUELLER	MH15023NK
		FORD METER BOX CO.	FFB11007NL
COMPRESSION FITTING	3/4" CC X CTS COMP CORP STOP	MUELLER	MH15008NF
		FORD METER BOX CO.	FF10003NL
MISC. FITTING - BRASS	2" FIP X FIP BV W/LS CURB STOP	MUELLER	MB20200NK
		FORD METER BOX CO.	FB11777WNL
MISC. FITTING - BRASS	1" X 3/4" 7.5" CTS X ORISEAL U-BRANCH	MUELLER	MH1460NGFWD
		FORD METER BOX CO.	NOT APPLICABLE
TAPPING SLEEVES & SADDLES	2" X 1" CC BRZ SADDLE F/IP PVC	MUELLER	MH13420G
		FORD METER BOX CO.	FS70204
TAPPING SLEEVES & SADDLES	3" X 1" BRZ SADDLE F/IP PVC	MUELLER	MH13425G
		FORD METER BOX CO.	FS70304
TAPPING SLEEVES & SADDLES	3" X 1" CC BRZ SADDLE F/CTS	MUELLER	NOT APPLICABLE
		FORD METER BOX CO.	NOT APPLICABLE
TAPPING SLEEVES & SADDLES	4" X 1" CC BRZ SADDLE F/CTS HDPE	MUELLER	MH1460NGFWD
TAPPING SLEEVES & SADDLES	4" X 1" CC BRZ SADDLE F/IP PVC	MUELLER	MH13428G
		FORD METER BOX CO.	FS70404
TAPPING SLEEVES & SADDLES	4" X 2" BRZ SADDLE F/IP PVC	MUELLER	MH13428K
		FORD METER BOX CO.	FS70407
TAPPING SLEEVES & SADDLES	4" X 2" CC BRZ SADDLE F/CTS	MUELLER	NOT APPLICABLE
		FORD METER BOX CO.	NOT APPLICABLE
TAPPING SLEEVES & SADDLES	6" X 1" BRZ SADDLE F/IP PVC	MUELLER	MH13431G
		FORD METER BOX CO.	FS70604
TAPPING SLEEVES & SADDLES	6" X 2" BRZ SADDLE F/IP PVC	MUELLER	MH13491K
		FORD METER BOX CO.	FS71607
TAPPING SLEEVES & SADDLES	8" X 1" BRZ SADDLE F/IP PVC	MUELLER	MH13433G
		FORD METER BOX CO.	FS71804
TAPPING SLEEVES & SADDLES	8" X 2" CC BRZ SADDLE F/IP PVC	MUELLER	MH13433K
		FORD METER BOX CO.	FS70807
TAPPING SLEEVES & SADDLES	10" X 2" CC BRZ SADDLE CTS HDPE	MUELLER	NOT APPLICABLE
TAPPING SLEEVES & SADDLES	10" X 2" CC BRZ SADDLE F/IP PVC	MUELLER	MH13443K
		FORD METER BOX CO.	FS701007
TAPPING SLEEVES & SADDLES	12" X 1" CC BRZ SADDLE CTS HDPE	MUELLER	NOT APPLICABLE
TAPPING SLEEVES & SADDLES	12" X 2" CC BRZ SADDLE F/IP PVC	MUELLER	MH13444K
		FORD METER BOX CO.	FS7001207
TAPPING SLEEVES & SADDLES	10" X 1" TAPPING SADDLE C-900	MUELLER	H13443-10X1
		FORD METER BOX CO.	S90-1004
TAPPING SLEEVES & SADDLES	10" X 2" BRASS SADDLE-CC THREAD	MUELLER	MH13443K
		FORD METER BOX CO.	FS901007
TAPPING SLEEVES & SADDLES	12" X 2" C-900 SADDLE	MUELLER	H13444-12X2
		FORD METER BOX CO.	S70-S90-1207
TAPPING SLEEVES & SADDLES	3" X 2" BRASS SADDLE-CC THREAD	MUELLER	NOT APPLICABLE
		FORD METER BOX CO.	NOT APPLICABLE

DEPARTMENT OF UTILITIES APPROVED FITTINGS FOR WATER			
CATEGORY	ITEM	APPROVED MANUFACTURER	MODEL/PART No.
TAPPING SLEEVES & SADDLES	3" X 2" TAPPING SADDLE C-900	MUELLER	NOT APPLICABLE
		FORD METER BOX CO.	NOT APPLICABLE
TAPPING SLEEVES & SADDLES	4" X 1" TAPPING SADDLE C-900	MUELLER	S13440
		FORD METER BOX CO.	S90-404
TAPPING SLEEVES & SADDLES	4" X 2" TAPPING SADDLE C-900	MUELLER	H13440-4X2
		FORD METER BOX CO.	S90-407
TAPPING SLEEVES & SADDLES	6" X 1" TAPPING SADDLE C-900	MUELLER	S13441-6X1
		FORD METER BOX CO.	S90-604
TAPPING SLEEVES & SADDLES	6" X 2" TAPPING SADDLE C-900	MUELLER	H13441-6X2
		FORD METER BOX CO.	S90-607
TAPPING SLEEVES & SADDLES	8" X 1" TAPPING SADDLE C-900	MUELLER	S13442-8X1
		FORD METER BOX CO.	FS70604
TAPPING SLEEVES & SADDLES	8" X 2" TAPPING SADDLE C-900	MUELLER	MH13491K
		FORD METER BOX CO.	FS71607

DATE:									
DESCRIPTION OF REVISION	No.								

DESIGNED BY: AH/CT	ISSUE DATE: 03/2023
DRAWN BY: AH	ISSUED BY: UTILITIES
CHECKED BY: BM/CT	SHEET SIZE: ANSI D
APPROVED BY: CT	SCALE: ---
DEPT. OF UTILITIES ST. TAMMANY PARISH GOVERNMENT 620 N. TYLER STREET COVINGTON, LA 70433	

DEPARTMENT OF UTILITIES  
 ST. TAMMANY PARISH GOVERNMENT  
 CONSTRUCTION STANDARDS FOR  
 WATER DISTRIBUTION

TABLE OF APPROVED FITTINGS