



24204 SOLICITATION TABLE OF CONTENTS

NIRC BUILDING 10B ELECTRICAL MODIFICATIONS (REBID)

Table with 2 columns: Item Number and Page No.
1. BIDDER CERTIFICATION INFORMATION1
2. SCOPE OF WORK2
3. COMPLIANCE TO SCHEDULE/LIQUIDATED DAMAGES2
4. BID SECURITY REQUIREMENTS2
5. LOUISIANA CONTRACTORS LICENSE REQUIREMENTS2
6. BOYCOTT PROHIBITION CLAUSE3
7. BUSINESS HOURS3
8. SITE VISIT CONTACT INFORMATION3
9. PRE-BID MEETING INFORMATION3
10. DETAILED SPECIFICATIONS4
11. ALTERNATE(S)4
12. SPECIAL NIRC REQUIREMENTS5
13. INSTRUCTIONS TO BIDDERS (Articles 1-9)6
14. SUPPLEMENTARY CONDITIONS (Articles 1-5, 7-15)13
15. INSURANCE REQUIREMENTS32
16. GENERAL REQUIREMENTS34
17. ELECTRONIC BID SUBMISSION GUIDELINES37
18. VENDOR CHECKLIST39
19. LOUISIANA UNIFORM PUBLIC WORK BID FORM40
20. ATTESTATIONS AFFIDAVIT FORM41
21. NON-COLLUSION AFFIDAVIT FORM43
22. PLANS – ATTACHMENT A (74 pages) FOLLOWS PAGE 43
23. DRAWINGS – ATTACHMENT BFOLLOWS ATTACHMENT A

UNIVERSITY OF LOUISIANA AT LAFAYETTE
Lafayette, Louisiana

SOLICITATION FILE NO. 24204

TITLE: NIRC BUILDING 10B ELECTRICAL MODIFICATIONS (REBID)

OPTIONAL PRE-BID MEETING (in person): Thursday, September 7, 2023, 9:00AM

BID SUBMISSION DEADLINE: Tuesday, October 10, 2023, 2:00PM

ZOOM BID OPENING: Tuesday, October 10, 2023, 3:00PM

PROPOSAL FOR FURNISHING ALL LABOR, MATERIALS, EQUIPMENT, TRANSPORTATION, SUPERVISION, PERMITS, ETC. NECESSARY FOR THE ELECTRICAL MODIFICATIONS TO BUILDING 10B - NIRC, LOCATED ON THE UL LAFAYETTE CAMPUS, IN NEW IBERIA, LOUISIANA.

BID DEADLINE

The Purchasing Office at the University of Louisiana at Lafayette will electronically receive proposals for this solicitation up to the above-mentioned date and time. Proposals will not be received after this specified hour and date. Bids will be publicly opened and read by a designated employee of the Purchasing Department.

This is a *Competitive Sealed Bid*. See *Guidelines for Electronic Submission of Bids and Virtual Bid Openings in the following pages of this solicitation, which contains complete details for submitting bids. Further information can be found in the attached INSTRUCTIONS TO BIDDERS.*

Bidders submitting bids in the amount of \$10,000.00 or more SHALL show their license number in the subject line of their electronic bid submission; bids not submitted in accordance with this requirement, SHALL be rejected and shall not be read.

Bid must be received by the due date and time in the Purchasing Office as per the instructions outlined in this solicitation. Bid must be submitted with the BID NUMBER IN THE SUBJECT LINE of the electronic submission. The public bid opening will take place on Tuesday, October 10, 2023 at 3:00PM on Zoom, which is available for viewing by registering at https://ullafayette.zoom.us/meeting/register/tJEqdemqpkzkiGtEpbS1A5EtSRpuHn_yEjkFJ.

Meeting ID: 957 2029 2905 Password: 24204

All inquiries regarding this request shall be directed to the Director of Purchasing at (337) 482-2955 or purchasing@louisiana.edu.

Attached is the completed proposal of the firm listed below. The undersigned certifies that he/she (or they) has/have carefully examined *the Instructions to Bidders, the General Conditions, and the Specifications* hereto attached and made part herein, and agrees to comply with the instructions, conditions, and specifications, as covered by the attached papers. On the basis of the specifications, the undersigned proposes to furnish any or all items listed in the schedule of items hereto attached, upon which prices are requested, and at the price stated for each item.

Firm Name

Signature [By signing this bid, bidder certifies compliance with La. R.S. 38:2212(A)(1)(c) or RS 38:2212(0)]

Address

Name (Printed)

City, State, Zip Code

Title

Telephone No. including area code

Date

Louisiana Contractor's License Number

E-Mail

GENERAL SPECIFICATIONS

FURNISH ALL LABOR, MATERIALS, EQUIPMENT, TRANSPORTATION, SUPERVISION, PERMITS, ETC. NECESSARY FOR THE ELECTRICAL MODIFICATIONS TO BUILDING 10B - NIRC, LOCATED ON THE UL LAFAYETTE CAMPUS, IN NEW IBERIA, LOUISIANA, AS SHOWN ON THESE SPECIFICATIONS...

SCOPE OF WORK

1. Provide and install electrical distribution system for new HVAC equipment
2. Provide and install new lighting, and power for Building 10B.

COMPLIANCE TO SCHEDULE/LIQUIDATED DAMAGES

DUE TO THE IMPORTANCE OF THE SCHEDULE, LIQUIDATED DAMAGES IN THE AMOUNT OF ONE HUNDRED DOLLARS (\$100.00) PER DAY WILL BE ASSESSED FOR EVERY CALENDAR DAY THAT THIS PROJECT IS NOT COMPLETE BEYOND TWO HUNDRED EIGHTY (280) DAYS OF THE NOTICE TO PROCEED.

BID SECURITY REQUIREMENTS

Each bidder MUST accompany his/her proposal with a bid security for five percent (5%) of the total maximum amount of his/her bid. The bid security shall be drawn in favor of the University of Louisiana at Lafayette and SHALL be in the form of a Bid Bond (Insurance Company), Bank Money Order*, Certified Check* or Cashier's Check*. It shall become the property of the Owner in the event the contract and any performance bond are not executed within the time set forth. Bid bond shall be written by a surety or insurance company currently on the US Department of the Treasury Financial Management Service List of Approved Bonding Companies which is published annually in the Federal Register, or by a Louisiana domiciled insurance company with at least an "A" - Rating in the latest printing of the AM Best's Key Rating Guide to write individual bonds up to ten percent (10%) of policyholders' surplus as shown in the AM Best's Key Rating Guide.

Successful bidder WILL BE required to execute and deliver within ten (10) days of notification, a satisfactory performance bond and payment bond in the amount of one hundred percent (100%) of the contract price. Performance Bond, with Power of Attorney, shall be secured by a surety or insurance company currently on the US Department of the Treasury Financial Management Service List of Approved Bonding Companies, and in accordance with restrictions set by them or by an insurance company that is either domiciled in Louisiana or owned by Louisiana residents and is licensed to write surety bonds. In addition, any surety bond written for a public works Project shall be written by a surety or insurance company that is currently licensed to do business in the State of Louisiana. Also, to be provided at the same time is a Labor and Materials payment Bond in an amount equal to one hundred percent (100%) of the contract amount.

*Bid security in the form of a Bank Money Order, Certified Check or Cashier's Check shall be scanned and included with the bid submission (front and back) and the original must be mailed to and received no later than 3 business days after the bid opening.

University of Louisiana at Lafayette
Purchasing Office
PO Box 40197
Lafayette, LA 70504-0197

LOUISIANA CONTRACTORS LICENSE REQUIREMENTS

Contractors or contracting firms submitting bids in the amount of \$10,000.00 or more shall certify that they are licensed contractors under Chapter 24 of Title 37 of the Louisiana Revised Statutes 1950 and show their license number ~~on the front of the sealed envelope in which their bid is enclosed~~ in the subject line of the email submission. Bids shall be accepted from

Contractors who are licensed under L.A. R.S. 37:2150-2163 in the following classification: ELECTRICAL CONSTRUCTION. Bids in the amount of \$10,000.00 or more, not submitted in accordance with this requirement, shall be rejected and shall not be read. Additional information relative to licensing may be obtained from the Louisiana State Licensing Board for Contractors, Baton Rouge, Louisiana.

In accordance with La. R.S. 38:2227, LA. R.S. 38:2212.10 and LA. R.S. 23:1726(B) each bidder on this Project must submit a completed Attestations Affidavit (Past Criminal Convictions of Bidders, Verification of Employees and Certification Regarding Unpaid Workers Compensation Insurance) form found within this bid package. The Attestations Affidavit form shall be submitted to the Purchasing Department within 10 days after the opening of bids. Affidavits submitted with the Bid Documents, prior to the opening of bids, will not be accepted in accordance with stated Revised Statute.

PROHIBITION OF DISCRIMINATORY BOYCOTTS OF ISRAEL

In accordance with LA R.S. 39:1602:1, for any contract for \$100,000 or more and for any contractor with five or more employees, Contractor, or any Subcontractor, shall certify it is not engaging in a boycott of Israel, and shall, for the duration of this contract, refrain from a boycott of Israel.

The State reserves the right to terminate this contract if the Contractor, or any Subcontractor, engages in a boycott of Israel during the term of the contract.

BUSINESS HOURS

Please send all correspondence electronically or through USPS. In-person delivery of document(s) will NOT be accepted. Business hours are Monday through Tuesday, 7:30 am to 11:45 am, 12:30 pm to 5:00 pm, and Friday, 7:30 am to 12:30 pm. The Purchasing Office will be closed during Federal, State and University holidays. It is the responsibility of the prospective bidder to be aware of such closures.

Please note that courier services such as UPS, FedEx, and DHL will be UNABLE to deliver to the Purchasing Office. See *Guidelines for Electronic Submission of Bids and Virtual Bid Openings on page 4 of this solicitation for more detailed information*.

In providing this bid, each bidder represents that: They have read and understand the bid documents and the bid is made in accordance herewith, and the bid is based upon the specifications described in the bid documents without exception.

SITE VISIT/CONTACT INFORMATION

It is the responsibility of the prospective bidder to visit and examine jobsite, take measurements to his/her own satisfaction, and determine conditions under which work is to be done. Owner will not accept responsibility for conditions which careful examination of premises would have shown existed.

To visit jobsite and for further information, prospective bidder is to contact Phillip J. Duplechin, 337-254-6868.

PRE-BID MEETING INFORMATION

A pre-bid meeting will be held at 9:00AM, Thursday, September 7, 2023, at the Ackal Hall Conference Room, Building 34, 4401 West Admiral Doyle Dr, New Iberia, LA 70560, at which time details of plans and specifications will be discussed.

TAX RELATED INFORMATION

It is the responsibility of the prospective bidder to pay taxes on materials purchased for this project. The University of Louisiana at Lafayette is a tax-exempt State Agency. However, that tax exempt status does not transfer to its contractors, subcontractors, suppliers, or vendors for their use.

For further information, prospective bidder should contact the Purchasing Department at purchasing@louisiana.edu, or call Mary Borel at 337-482-9051.

END OF SECTION

DETAILED SPECIFICATIONS

PROPOSAL FOR FURNISHING ALL LABOR, MATERIALS, EQUIPMENT, TRANSPORTATION, SUPERVISION, PERMITS, ETC. NECESSARY FOR THE NIRC – BUILDING 10B ELECTRICAL MODIFICATIONS, LOCATED ON THE UL LAFAYETTE CAMPUS, IN NEW IBERIA, LOUISIANA, AS SHOWN ON THESE SPECIFICATIONS...

Base Bid

SCOPE OF WORK

1. Provide and install electrical distribution system for new HVAC equipment
2. Provide and install new lighting, and power for Building 10B.

(See Attachment A) – Electrical Specifications

END OF SECTION

BUILDING PLANS/DRAWINGS

Drawings and plans are included with this solicitation as Attachment B.

END OF SECTION

ALTERNATES

- Alternate No. 1 – N/A
- Alternate No. 2 – N/A
- Alternate No. 3 – N/A

END OF SECTION

Special Requirements Specific to the New Iberia Research Center (if applicable)

MEDICAL REQUIREMENTS

The Contractor shall have all on-site technicians/crew members provide proof of Measles immunization or positive Measles Titer to the Center representative prior to entering the Facility. The Contractor shall also supply proof of a negative TB test every 6 months for all on-site technicians/crew members for the duration of the Contract. Failure to supply appropriate medical documentation will restrict the technician(s)/crew member(s) from entry onto the Center premises until such time as the requirements are satisfactorily met. In addition, technicians/crew members shall be in overt good health with no signs of infectious disease to include fever, respiratory disease, gastrointestinal dysfunction or cold sores.

There will be no grace period for the performance of the medical requirements.

ENHANCED SECURITY CLEARANCE (CONTRACTORS):

The Contractor shall have all technicians/crew members submit to an Enhanced Security Clearance screening, prior to granting the individual access to the University of Louisiana at Lafayette's New Iberia Research Center's (NIRC) Facility. The screening of technicians/crew members will be conducted through Information Network Associates (INA), www.ina-inc.com and will be the sole responsibility of the New Iberia Research Center. The New Iberia Research Center will contact INA directly to request the "UL-NIRC Enhanced Security Clearance screening" be performed.

Eligibility for contracted employment with NIRC and access to the Facility, will be classified as a "Security Clearance", and will be granted only to those individuals whom have undergone the appropriate Enhanced Security Screening. Continued association with NIRC and access to the Facility is contingent upon maintaining a satisfactory Security Clearance.

A successful Security Clearance shall be considered a condition of the Contract. Any existing and/or new technician/crew member failing to satisfactorily pass the Enhanced Security Clearance will not be allowed to enter the Facility. The Contractor shall use its best efforts to assign technicians/crew members reasonably believed to be able to meet the Enhanced Security Clearance requirements.

There will be no grace period for the performance of the Enhanced Security Clearance screening.

GENERAL CLEAN-UP

The general Contractor shall be responsible for providing a dumpster and for the proper disposal of all work associated debris at an appropriate (for the type of debris), approved landfill.

The general Contractor shall be responsible for leaving the space, free of dust and mopped clean.

All surfaces shall be wiped down and free of dust.

END OF SECTION

INSTRUCTIONS TO BIDDERS

[https://www.doa.la.gov/.../24 Instructions to Bidders July2018.docx](https://www.doa.la.gov/.../24%20Instructions%20to%20Bidders%20July2018.docx)

ARTICLE 1

DEFINITIONS

- 1.1 The Bid Documents include the following:
- Advertisement for Bids (if applicable)
 - Instructions to Bidders
 - Bid Form
 - Bid Bond Instruction
 - General Conditions of the Contract for Construction, AIA Document A201, 2017 Edition
 - Supplementary Conditions
 - Contract Between Owner and Contractor and Performance and Payment Bond
 - Mandatory Affidavits
 - User Agency Documents (if applicable)
 - Change Order Form (if applicable)
 - Partial Occupancy Form (if applicable)
 - Recommendation of Acceptance (if applicable)
 - Asbestos Abatement (if applicable)
 - Other Documents (if applicable)
 - Specifications & Drawings
 - Addenda issued during the bid period and acknowledged on the Bid Form (if applicable)
- 1.2 All definitions set forth in the General Conditions of the Contract for Construction, AIA Document A201 and the Supplementary Conditions are applicable to the Bid Documents.
- 1.3 Addenda are written and/or graphic instruments issued by the Architect or Purchasing Office prior to the opening of bids, which modify or interpret the Bid Documents by additions, deletions, clarifications, corrections and prior approvals.
- 1.4 A bid is a complete and properly signed proposal to do the work or designated portion thereof for the sums stipulated therein supported by data called for by the Bid Documents.
- 1.5 Base bid is the sum stated in the bid for which the Bidder offers to perform the work described as the base, to which work may be added, or deleted for sums stated in alternate bids.
- 1.6 An alternate bid (or alternate) is an amount stated in the bid to be added to the amount of the base bid if the corresponding change in Project scope or materials or methods of construction described in the Bid Documents is accepted.
- 1.7 A Bidder is one who submits a bid for a prime Contract with the Owner for the work described in the Bid Documents.
- 1.8 A Sub-bidder is one who submits a bid to a Bidder for materials and/or labor for a portion of the work.
- 1.9 Where the word "Architect" is used in any of the documents, it shall refer to the Prime Designer of the Project, regardless of discipline.

ARTICLE 2

PRE-BID CONFERENCE

- 2.1 A Pre-Bid Conference shall be held at least 10 days before the date for receipt for bids. The Architect shall coordinate the setting of the date, time and place for the Pre-Bid Conference with the User Agency and shall notify in writing the

Owner and all who have received sets of the Bid Documents to attend. The purpose of the Pre-Bid Conference is to familiarize Bidders with the requirements of the Project and the intent of the Bid Documents, and to receive comments and information from interested Bidders. If the Pre-Bid Conference is stated in the Advertisement for Bids to be a Mandatory Pre-Bid Conference, bids shall be accepted only from those bidders who attend the Pre-Bid Conference. Contractors who are not in attendance for the entire Pre-Bid Conference will be considered to have not attended.

- 2.2 Any revision of the Bid Documents made as a result of the Pre-Bid Conference shall not be valid unless included in an addendum.

ARTICLE 3

BIDDER'S REPRESENTATION

- 3.1 Each Bidder by making his bid represents that:

- 3.1.1 He has read and understands the Bid Documents and his bid is made in accordance therewith.
- 3.1.2 He has visited the site and has familiarized himself with the local conditions under which the work is to be performed.
- 3.1.3 His bid is based solely upon the materials, systems and equipment described in the Bid Documents as advertised and as modified by addenda.
- 3.1.4 His bid is not based on any verbal instructions contrary to the Bid Documents and addenda.
- 3.1.5 He is familiar with Code of Governmental Ethics requirement that prohibits public servants and/or their immediate family members from bidding on or entering into contracts; he is aware that the Designer and its principal owners are considered Public Servants under the Code of Governmental Ethics for the limited purposes and scope of the Design Contract with the State on this Project (see Ethics Board Advisory Opinion, No. 2009-378 and 2010-128); and neither he nor any principal of the Bidder with a controlling interest therein has an immediate family relationship with the Designer or any principal within the Designer's firm (see La. R.S. 42:1113). Any Bidder submitting a bid in violation of this clause shall be disqualified and any contract entered into in violation of this clause shall be null and void.

- 3.2 The Bidder must be fully qualified under any State or local licensing law for Contractors in effect at the time and at the location of the work before submitting his bid. In the State of Louisiana, Revised Statutes 37:2150, et seq. will be considered, if applicable.

The Contractor shall be responsible for determining that all of his Sub-bidders or prospective Subcontractors are duly licensed in accordance with law.

ARTICLE 4

BID DOCUMENTS

- 4.1 Copies

- 4.1.1 Bid Documents may be obtained from the Architect for a deposit as stated in the Advertisement for Bids. The deposit will be refunded as stated in the Advertisement for Bids. No deposits will be refunded on Bid Documents returned later than ten days after receipt of bids.

- 4.1.1.2 As an alternative method of distribution, the Designer may provide the Bid Documents in electronic format. They may be obtained without charge and without deposit as stated in the Advertisement for Bids.

- 4.1.1.2.1 If electronic distribution is available, printed copies will not be available from the Designer, but arrangements can be made to obtain them through most reprographic firms and/or plan rooms.

- 4.1.1.2.2 If electronic distribution is available, the reproduction cost on the first paper plan set acquired by bona fide prime bidders will be fully refunded by the Designer upon

delivery of the documents to the Designer in good condition no later than ten days after receipt of bids.

- 4.1.1.2.3 If electronic distribution is available, all other plan holders are responsible for their own reproduction costs.

4.1.2 Complete sets of Bid Documents shall be used in preparing bids; neither the Owner nor the Architect assume any responsibility for errors or misinterpretations resulting from the use of incomplete sets of Bid Documents.

4.1.3 The Owner or Architect in making copies of the Bid Documents available on the above terms, do so only for the purpose of obtaining bids on the work and do not confer a license or grant for any other use.

4.2 Interpretation or Correction of Bid Documents

4.2.1 Bidders shall promptly notify the Architect of any ambiguity, inconsistency or error which they may discover upon examination of the Bid Documents or of the site and local conditions.

4.2.2 Bidders requiring clarification or interpretation of the Bid Documents shall make a written request to the Architect, to reach him at least seven days prior to the date for receipt of bids.

4.2.3 Any interpretation, correction or change of the Bid Documents will be made by addendum. Interpretations, corrections or changes of the Bid Documents made in any other manner will not be binding and Bidders shall not rely upon such interpretations, corrections and changes.

4.3 Substitutions

4.3.1 The materials, products and equipment described in the Bid Documents establish a standard of required function, dimension, appearance, and quality to be met by any proposed substitution. No substitutions shall be allowed after bids are received.

4.3.2 No substitution will be considered unless written request for approval has been submitted by the Proposer and has been received by the Architect at least seven (7) working days prior to the opening of bids. (La. R.S. 38:2295(C)) Each such request shall include the name of the material or equipment for which it is to be substituted and a complete description of the proposed substitute including model numbers, drawings, cuts, performance and test data and any other information necessary for an evaluation. A statement setting forth any changes in other materials, equipment or work that incorporation of the substitute would require shall be included. It shall be the responsibility of the proposer to include in his proposal all changes required of the Bid Documents if the proposed product is used. Prior approval, if given, is contingent upon supplier being responsible for any costs which may be necessary to modify the space or facilities needed to accommodate the materials and equipment approved.

4.3.3 If the Architect approves any proposed substitution, such approval shall be set forth in an addendum. Bidders shall not rely upon approvals made in any other manner.

4.4 Addenda

4.4.1 Addenda will be transmitted to all who are known by the Architect to have received a complete set of Bid Documents.

4.4.2 Copies of addenda will be made available for inspection wherever Bid Documents are on file for that purpose.

4.4.3 Except as described herein, addenda shall not be issued within a period of seventy-two (72) hours prior to the advertised time for the opening of bids, excluding Saturdays, Sundays, and any other legal holidays. If the necessity arises of issuing an addendum modifying plans and specifications within the seventy-two (72) hour period prior to the advertised time for the opening of bids, then the opening of bids shall be extended at least seven but no more than twenty-one (21) working days, without the requirement of re-advertising. UL Lafayette Purchasing shall be consulted prior to issuance of such an addendum and shall approve such issuance. The

revised time and date for the opening of bids shall be stated in the addendum.

- 4.4.4 Each Bidder shall ascertain from the Architect prior to submitting his bid that he has received all addenda issued, and he shall acknowledge their receipt on the Bid Form.
- 4.4.5 The Owner shall have the right to extend the bid date by up to (30) thirty days without the requirement of re-advertising. Any such extension shall be made by addendum issued.

ARTICLE 5

BID PROCEDURE

5.1 Form and Style of Bids

- 5.1.1 Bids shall be submitted on the Louisiana Uniform Public Work Bid Form provided by the Architect for this Project.
- 5.1.2 The Bidder shall ensure that all applicable blanks on the bid form are completely and accurately filled in.
- 5.1.3 Bid sums shall be expressed in both words and figures, and in case of discrepancy between the two, the written words shall govern.
- 5.1.4 Any interlineation, alteration or erasure must be initialed by the signer of the bid or his authorized representative.
- 5.1.5 Bidders are cautioned to complete all alternates should such be required on the Bid Form. Failure to submit alternate prices will render the bid non responsive and shall cause its rejection.
- 5.1.6 Bidders are cautioned to complete all unit prices should such be required in the Bid Form. Unit prices represent a price proposal to do a specified quantity and quality of work. Unit prices are incorporated into the base bid or alternates, as indicated on the Unit Price Form, but are not the sole components thereof.
- 5.1.7 Bidder shall make no additional stipulations on the Bid Form nor qualify his bid in any other manner.
- 5.1.8 Written evidence of the authority of the person signing the bid for the public work shall be submitted in accordance with La. R.S. 38:2212 (B)(5).
- 5.1.9 On any bid in excess of fifty thousand dollars (\$50,000.00), the Contractor shall certify that he is licensed under La. R.S. 37: 2150-2173 and show his license number on the bid above his signature or his duly authorized representative.

5.2 Bid Security

- 5.2.1 No bid shall be considered or accepted unless the bid is accompanied by bid security in an amount of five percent (5.0%) of the base bid and all alternates.

The bid security shall be in the form of a certified check, cashier's check drawn on a bank insured by the Federal Deposit Insurance Corporation, or a Bid Bond written by a surety company licensed to do business in Louisiana and signed by the surety's agent or attorney-in-fact. The surety for the bond must meet the qualifications stated thereon. The Bid Bond shall include the legal name of the bidder be in favor of the University of Louisiana at Lafayette, and shall be accompanied by appropriate power of attorney. The Bid Bond must be signed by both the bidder/principal. Failure by the bidder/principal or the surety to sign the bid bond shall result in the rejection of the bid.

Bid security furnished by the Contractor shall guarantee that the Contractor will, if awarded the work according to the terms of his proposal, enter into the Contract and furnish Performance and Payment Bonds as required by these Bid Documents, within fifteen (15) days after written notice that the instrument is ready for his signature.

Should the Bidder refuse to enter into such Contract or fail to furnish such bonds, the amount of the bid security

shall be forfeited to the Owner as liquidated damages, not as penalty.

- 5.2.2 The Owner will have the right to retain the bid security of Bidders until either (a) the Contract has been executed and bonds have been furnished, or (b) the specified time has elapsed so that bids may be withdrawn, or (c) all bids have been rejected.

5.3 Submission of Bids

See Guidelines for Electronic Submission of Bids and Virtual Bid Openings included in this solicitation.

- 5.3.1 ~~The Bid shall be sealed in an opaque envelope. The bid envelope shall be identified on the outside the name, address, and license number of the Bidder.~~

~~The envelope shall not contain multiple bid forms, and will be received until the time specified and at the place specified in the Advertisement for Bids. It shall be the specific responsibility of the Bidder to deliver his sealed bid to The University at the appointed place and prior to the announced time for the opening of bids. Late delivery of a bid for any reason, including late delivery by United States Mail, or express delivery, shall disqualify the bid.~~

~~If the bid is sent by mail, the sealed envelope shall be enclosed in a separate mailing envelope with the notation "Bid Enclosed" on the face thereof. Such bids shall be sent by Registered or Certified Mail, Return Receipt Requested, addressed to:~~

~~University of Louisiana at Lafayette
Purchasing Department,
P. O. Box 40197
Lafayette, LA 70504~~

~~Bids sent by express delivery shall be delivered to:~~

~~— University of Louisiana at Lafayette —
— Purchasing Department
Martin Hall, Room 123
104 University Circle
Lafayette, LA 70503~~

IMPORTANT: BIDS WILL NOT BE ACCEPTED BY U.S. MAIL OR IN-PERSON DELIVERY TO THE PURCHASING OFFICE. ANY REFERENCE TO SEALED ENVELOPES AND OR MAILED DOCUMENTS ARE TO BE DISREGARDED BY POTENTIAL BIDDERS. COURIER SERVICES SUCH AS UPS, FedEx, and DHL WIL NOT BE ABLE TO DELIVERY TO OUR PHYSICAL LOCATION AND THE BUILDING MAY BE LOCKED OR UNSTAFFED.

- 5.3.2 Bids shall be deposited at the designated location prior to the time on the date for receipt of bids indicated in the Advertisement for Bids, or any extension thereof made by addendum. Bids received after the time and date for receipt of bids will be returned unopened.

5.3.3 Bidder shall assume full responsibility for timely delivery at location designated for receipt of bids.

5.3.4 Oral, telephonic or telegraphic bids are invalid and shall not receive consideration. Owner shall not consider notations written on outside of bid form ~~envelope~~ which have the effect of amending the bid. Written modifications enclosed in the bid ~~envelope~~, and signed or initialed by the Contractor or his representative, shall be accepted.

5.4 Modification or Withdrawal of Bid

- 5.4.1 A bid may not be modified, withdrawn or canceled by the Bidder during the time stipulated in the Advertisement for Bids, for the period following the time and bid date designated for the receipt of bids, and Bidder so agrees in submitting his bid, except in accordance with R.S. 38:2214 which states, in part, "Bids containing patently obvious, unintentional, and substantial mechanical, clerical, or mathematical errors, or

errors of unintentional omission of a substantial quantity of work, labor, material, or services made directly in the compilation of the bid, may be withdrawn by the contractor if clear and convincing sworn, written evidence of such errors is furnished to the public entity within forty- eight hours of the bid opening excluding Saturdays, Sundays, and legal holidays".

- 5.4.2 Prior to the time and date designated for receipt of bids, bids submitted early may be modified or withdrawn only by notice to the party receiving bids at the place and prior to the time designated for receipt of bids.
- 5.4.3 Withdrawn bids may be resubmitted up to the time designated for the receipt of bids provided that they are then fully in conformance with these Instructions to Bidders.
- 5.4.4 Bid Security shall be in an amount sufficient for the bid as modified or resubmitted.

5.5 Prohibition of Discriminatory Boycotts of Israel

By submitting a bid, the bidder certifies and agrees that the following information is correct:

In preparing its bid, the bidder has considered all proposals submitted from qualified, potential subcontractors and suppliers, and has not, in the solicitation, selection, or commercial treatment of any subcontractor or supplier, refused to transact or terminated business activities, or taken other actions intended to limit commercial relations, with a person or entity that is engaging in commercial transactions in Israel or Israel-controlled territories, with the specific intent to accomplish a boycott or divestment of Israel. The bidder has also not retaliated against any person or other entity for reporting such refusal, termination, or commercially limiting actions. The state reserves the right to reject any bid if this certification is subsequently determined to be false and to terminate any contract awarded based on such a false response.

ARTICLE 6 CONSIDERATION OF BIDS

6.1 Opening of Bids

See Guidelines for Electronic Submission of Bids and Virtual Bid Openings on page 37 of this solicitation.

- 6.1.1 The properly identified Bids received on time will be opened publicly and will be read aloud, and a tabulation abstract of the amounts of the base bids and alternates, if any, will be made available to Bidders.

6.2 Rejection of Bids

- 6.2.1 The Owner shall have the right to reject any or all bids and in particular to reject a bid not accompanied by any required bid security or data required by the Bid Documents or a bid in any way incomplete or irregular.

6.3 Acceptance of Bid

- 6.3.1 It is the intent of the Owner, if he accepts any alternates, to accept them in the order in which they are listed in the Bid Form. Determination of the Low Bidder shall be on the basis of the sum of the base bid and the alternates accepted. However, the Owner shall reserve the right to accept alternates in any order which does not affect determination of the Low Bidder.

ARTICLE 7 POST-BID INFORMATION

7.1 Submissions

- 7.1.1 At the Pre-Construction Conference, the Contractor shall submit the following information to the Architect.
 - 7.1.1.1 A designation of the work to be performed by the Contractor with his own forces.
 - 7.1.1.2 A breakdown of the Contract cost attributable to each item listed in the Schedule of Values Form (attached). No payments will be made to the Contractor until this is received.
 - 7.1.1.3 The proprietary names and the suppliers of principal items or systems of material and equipment proposed for the work.
 - 7.1.1.4 A list of names and business domiciles of all Subcontractors, manufacturers, suppliers or other persons or organizations (including those who are to furnish materials or equipment fabricated to a

special design) proposed for the principal portions of the work. It is the preference of the Owner that, to the greatest extent possible or practical, the Contractor utilize Louisiana Subcontractors, manufacturers, suppliers, and labor.

7.1.2 The General Contractor shall be responsible for actions or inactions of Subcontractors and/or material suppliers.

The General Contractor is totally responsible for any lost time or extra expense incurred due to a Subcontractor's or Material Supplier's failure to perform. Failure to perform includes, but is not limited to, a Subcontractor's financial failure, abandonment of the Project, failure to make prompt delivery, or failure to do work up to standard. Under no circumstances shall the Owner mitigate the General Contractor's losses or reimburse the General Contractor for losses caused by these events.

7.1.3 The lowest responsive and responsible bidder shall submit to the Architect and the Owner within ten days after the bid opening a letter/letters from the manufacturer stating that the manufacturer will issue the roof system guarantee complying with the requirements of Facility Planning and Control based on the specified roof system and include the name of the applicator acceptable to the manufacturer at the highest level of certification for installing the specified roof system. This manufacturer shall be one that has received prior approval or is named in the specifications.

In accordance with La. R.S. 38:2227 [references La R.S. 38:2212(A)(3)(c)(ii), which has since been renumbered as La R.S. 38:2212(B)(3)], La. R.S. 38:2212.10 and La. R.S. 23:1726(B) the apparent low bidder on this Project shall submit the completed Attestations Affidavit (Past Criminal Convictions of Bidders, Verification of Employees and Certification Regarding Unpaid Workers Compensation Insurance) form found within this bid package to the University of Louisiana at Lafayette within 10 days after the opening of bids.

ARTICLE 8

PERFORMANCE AND PAYMENT BOND

8.1 Bond Required

8.1.1 The Contractor shall furnish and pay for a Performance and Payment Bond written by a company licensed to do business in Louisiana, which shall be signed by the surety's agent or attorney-in-fact, in an amount equal to 100% of the Contract amount. Surety must be listed currently on the U. S. Department of Treasury Financial Management Service List (Treasury List) as approved for an amount equal to or greater than the contract amount or must be an insurance company domiciled in Louisiana or owned by Louisiana residents. If surety is qualified other than by listing on the Treasury list, the contract amount may not exceed fifteen percent of policyholders' surplus as shown by surety's most recent financial statements filed with the Louisiana Department of Insurance and may not exceed the amount of \$500,000. However, a Louisiana domiciled insurance company with at least an A- rating in the latest printing of the A. M. Best's Key Rating Guide shall not be subject to the \$500,000 limitation, provided that the contract amount does not exceed ten percent of policyholders' surplus as shown in the latest A. M. Best's Key Rating Guide nor fifteen percent of policyholders' surplus as shown by surety's most recent financial statements filed with the Louisiana Department of Insurance. The Bond shall be signed by the surety's agent or attorney-in-fact. The Bond shall be in favor of the University of Louisiana at Lafayette.

8.2 Time of Delivery and Form of Bond

8.2.1 The Bidder shall deliver the required bond to the Owner simultaneous with the execution of the Contract.

8.2.2 A surety company's bid bond form/document will be sufficient for any bid submission.

8.2.3 The Bidder shall require the Attorney-in-Fact who executes the required bond on behalf of the surety to affix thereto a certified and current copy of his power of Attorney.

ARTICLE 9

FORM OF AGREEMENT BETWEEN OWNER AND CONTRACTOR

9.1 Form to be Used

- 9.1.1 Form of the Contract to be used shall be furnished by the University of Louisiana at Lafayette, an example of which is bound in the Bid Documents.
- 9.2 Award
- 9.2.1 After award of the Contract, the successful Bidder, if a corporation, shall furnish to the Owner the most current copy of a Disclosure of Ownership Affidavit on file with the Secretary of State.
- 9.2.2 In accordance with Louisiana Law, when the Contract is awarded, the successful Bidder shall, at the time of the signing of the Contract, execute the Non-Collusion Affidavit included in the Contract Documents
- 9.2.3 When this Project is financed either partially or entirely with State Bonds, the award of this Contract is contingent upon the sale of bonds by the State Bond Commission. The State shall incur no obligation to the Contractor until the Contract Between Owner and Contractor is duly executed.

END OF SECTION

SUPPLEMENTARY CONDITIONS

https://www.doa.la.gov/.../27_Supplementary_Conditions_April2018.docx

These Supplementary Conditions modify, change, delete from or add to the General Conditions of the Contract for Construction, AIA Document A201, 2017 Edition. Where any Article of the General Conditions is modified or any Section, Paragraph, Subparagraph or Clause thereof is modified or deleted by these supplements, the unaltered provisions of that Section, Article, Paragraph, Subparagraph or Clause shall remain in effect.

Articles, Sections, Paragraphs, Subparagraphs or Clauses modified or deleted have the same numerical designation as those occurring in the General Conditions.

ARTICLE 1

GENERAL PROVISIONS

1.1 BASIC DEFINITIONS

1.1.1 The Contract Documents

In Section 1.1.1 delete the third sentence, and add the following sentence:

The Contract Documents shall include the Bid Documents as listed in the Instructions to Bidders and any modifications made thereto by addenda.

1.1.8 Initial Decision Maker

Delete all after the words, "shall not show partiality to the Owner or Contractor".

1.5 OWNERSHIP AND USE OF DRAWINGS, SPECIFICATIONS AND OTHER INSTRUMENTS OF SERVICE [REFER TO *La R.S. 38:2317*]

1.5.1 Delete the first sentence of the paragraph.

1.5.1 In the third sentence: delete the remainder after the word "publication".

1.7 DIGITAL DATA USE AND TRANSMISSION

In the first sentence after the words, "in digital form" delete ". The parties will use AIA Document E203 2013, Building Information Modeling and Digital Data Exhibit".

1.8 BUILDING INFORMATION MODELS USE AND RELIANCE

Delete Section 1.8.

ARTICLE 2

OWNER

2.2 EVIDENCE OF THE OWNER'S FINANCIAL ARRANGEMENTS

Delete Section 2.2.

2.3 INFORMATION AND SERVICES REQUIRED OF THE OWNER

2.3.1 In the first sentence, delete: all before "the Owner shall secure..."

Delete Section 2.3.2 and substitute the following:

2.3.2 The term Architect, when used in the Contract Documents, shall mean the prime Designer (Architect, Engineer, or Landscape Architect), or his authorized representative, lawfully licensed to practice architecture, engineering, or landscape architecture in the State of Louisiana, identified as such in the Agreement and is referred to throughout the Contract Documents as if singular in number.

2.3.3 Delete the words: "to whom the Contractor has no reasonable objection and".

ARTICLE 3

CONTRACTOR

3.4 LABOR AND MATERIALS

3.4.2 Delete Section 3.4.2.

Delete Section 3.4.3 and substitute with the following:

3.4.3 Contractor and its employees, officers, agents, representatives, and Subcontractors shall conduct themselves in an appropriate and professional manner, in accordance with the Owner's requirements, at all times while working on the Project. Any such individual who behaves in an inappropriate manner or who engages in the use of inappropriate language or conduct while on Owner's property, as determined by the Owner, shall be removed from the Project at the Owner's request. Such individual shall not be permitted to return without the written permission of the Owner. The Owner shall not be responsible or liable to Contractor or any Subcontractor for any additional costs, expenses, losses, claims or damages incurred by Contractor or its Subcontractor as a result of the removal of an individual from the Owner's property pursuant to this Section. The Contractor shall not permit employment of unfit persons or persons not properly skilled in tasks assigned to them.

3.5 WARRANTY

3.5.2 Replace reference to "Section 9.8.4" with "Section 9.8.6".

3.7 PERMITS, FEES, NOTICES, AND COMPLIANCE WITH LAWS (La R.S. 40:1724[A])

3.7.1 Delete Section 3.7.1.

3.7.2 In Section 3.7.2, replace the word "public" with the word "State".

Delete Section 3.7.5 and substitute the following:

3.7.5 If, during the course of the Work, the Contractor discovers human remains, unmarked burial or archaeological sites, burial artifacts, or wetlands, which are not indicated in the Contract Documents, the Contractor shall follow all procedures mandated by State and Federal law, including but not limited to La R.S. 8:671 et seq., the Office of Coastal Protection and Restoration, and Sections 401 & 404 of the Federal Clean Water Act. Request for adjustment of the Contract Sum and Contract Time arising from the

existence of such remains or features shall be submitted in writing to the Owner pursuant to the Contract Documents.

3.8 ALLOWANCES

Delete Sections 3.8.1, 3.8.2, and 3.8.3 in their entirety and add the following new Section 3.8.1:

3.8.1 Allowances shall not be made on any of the Work.

3.9 SUPERINTENDENT

3.9.1 Add the following to the end of the paragraph:
Important communications shall be confirmed in writing. Other communications shall be similarly confirmed on written request in each case.

3.10 CONTRACTOR'S CONSTRUCTION AND SUBMITTAL SCHEDULES

3.10.1 Add the following: For Projects with a contract sum greater than \$1,000,000.00, the Contractor shall include with the schedule, for the Owner's and Architect's information, a network analysis to identify those tasks which are on the critical path, i.e., where any delay in the completion of these tasks will lengthen the Project timescale, unless action is taken. A revised schedule shall be submitted with each Application and Certificate for Payment. No payment shall be made until this schedule is received.

3.10.3 In the first sentence, delete the word "general".

After the first sentence, add the following:

If the Work is not on schedule, as determined by the Architect, and the Contractor fails to take action to bring the Work on schedule, then the Contractor shall be deemed in default under this Contract and the progress of the Work shall be deemed unsatisfactory. Such default may be considered grounds for termination by the Owner for cause in accordance with Section 14.2.

Add the following Sections:

3.10.4 Add the following: Submittal by the contractor of a schedule or other documentation showing a completion date for his Work prior to the completion date stated in the contract shall not impose any obligation or responsibility on the Owner or Architect for the earlier completion date.

3.10.5 In the event the Owner employs a commissioning consultant, the Contractor shall cooperate fully in the commissioning process and shall require all subcontractors and others under his control to cooperate. The purpose of such services shall be to ensure that all systems perform correctly and interactively according to the provisions of the Contract Documents.

3.11 DOCUMENTS AND SAMPLES AT THE SITE

Add the following: This requirement is of the essence of the contract. The Architect shall determine the value of these documents and this amount shall not be approved for payment to the Contractor until all of the listed documents are delivered to the Architect in good order, completely marked with field changes and otherwise complete in all aspects.

ARTICLE 4 ARCHITECT

4.2 ADMINISTRATION OF THE CONTRACT

4.2.1 In the first sentence, delete the phrase: "the date the Architect issues the final Certificate for Payment" and replace with the phrase "final payment is due, and with the Owner's concurrence, from time to time during the one year period for correction of Work described in Section 12.2."

- 4.2.2 In the first sentence, after the phrase: “become generally familiar with”; insert the following: “and to keep the Owner informed about”.
- In the first sentence, after the phrase “portion of the Work completed”, insert the following: “to endeavor to guard the Owner against defects and deficiencies in the Work,”
- 4.2.4 In the first sentence, delete all after “The Owner and Contractor”, and add the following “may communicate directly with each other, when deemed necessary by the Owner, and the Owner will notify the Architect of any decision.”
- 4.2.10 Add the following sentence to the end of Section 4.2.10: There shall be no restriction on the Owner having a Representative.
- 4.2.11 Add the following sentence to the end of Section 4.2.11:
If no agreement is made concerning the time within which interpretation required of the Architect shall be furnished in compliance with this Section 4.2, then delay shall not be recognized on account of failure by the Architect to furnish such interpretation until 15 days after written request is made for them.
- 4.2.14 Insert the following sentence between the second and third sentences of Section 4.2.14:
If no agreement is made concerning the time within which interpretation required of the Architect shall be furnished in compliance with this Section 4.2, then delay shall not be recognized on account of failure by the Architect to furnish such interpretation until 15 days after written request is made for them.

ARTICLE 5

SUBCONTRACTORS

5.2 AWARD OF SUBCONTRACTS AND OTHER CONTRACTS FOR PORTIONS OF THE WORK

Delete Section 5.2.1, and substitute the following:

- 5.2.1 Unless otherwise required by the Contract Documents, the Contractor shall furnish at the Pre-Construction Conference, to the Owner and the Architect, in writing, the names of the persons or entities (including those who are to furnish materials or equipment fabricated to a special design) proposed for each of the principal portions of the Work. No Contractor payments shall be made until this information is received.

5.2.2

Delete Section 5.2.2, and substitute the following:

- 5.2.2 The Contractor shall be solely responsible for selection and performance of all subcontractors. The Contractor shall not be entitled to claims for additional time and/or an increase in the contract sum due to a problem with performance or nonperformance of a subcontractor.

Delete Sections 5.2.3 and 5.2.4 and substitute the following:

- 5.2.3 The Contractor shall notify the Architect and the Owner when a subcontractor is to be changed and substituted with another subcontractor.

5.4 CONTINGENT ASSIGNMENT OF SUBCONTRACTS

Delete Sections 5.4, 5.4.1, 5.4.2 and 5.4.3

ARTICLE 7

CHANGES IN THE WORK

7.1 GENERAL

Add the following Sections:

- 7.1.4 As part of the pre-construction conference submittals, the Contractor shall submit the following prior to the Contractor's initial request for payment:
- 7.1.4.1 Fixed job site overhead cost itemized with documentation to support daily rates.
 - 7.1.4.2 Bond Premium Rate with supporting information from the General Contractor's carrier.
 - 7.1.4.3 Labor Burden by trade for both Subcontractors and General Contractor. The Labor Burden shall be supported by the Worker's Compensation and Employer's Liability Insurance Policy Information Page. Provide for all trades.
 - 7.1.4.4 Internal Rate Charges for all significant company owned equipment.
- 7.1.5 If the General Contractor fails to submit the aforementioned documentation as part of the pre-construction submittals, then pay applications shall not be processed until such time as the Owner receives this information.

7.2 CHANGE ORDERS

Delete Section 7.2.1, and substitute the following Sections:

- 7.2.1 A Change Order is a written instrument prepared by the Architect and signed by the Owner, the Architect, and the Contractor issued after execution of the Contract, authorizing a change in the Work and/or an adjustment in the Contract Sum and/or the Contract Time. The Contract Sum and the Contract Time may be changed only by Change Order. A Change Order signed by the Contractor indicates his agreement therewith, including the adjustment in the Contract Sum or the Contract Time. Any reservation of rights, stipulation, or other modification made on the change order by the contractor shall have no effect.
- 7.2.2 "Cost of the Work" for the purpose of Change Orders shall be the eligible costs required to be incurred in performance of the Work and paid by the Contractor and Subcontractors which eligible costs shall be limited to:
- 7.2.2.1 Actual wages paid directly to labor personnel, with a labor burden markup exclusively limited to applicable payroll taxes, worker's compensation insurance, unemployment compensation, and social security taxes for those labor personnel performing the Work. Wages shall be the basic hourly labor rate paid an employee exclusive of fringe benefits or other employee costs. The labor burden percentage for the "Cost of the Work" is limited to categories listed herein. Employer-provided health insurance, fringe benefits, employee training (whether a requirement of employment or not), vacation pay, etc., are examples of ineligible labor burden costs which *shall not* be included, as these costs are already compensated by the Overhead and Profit markup.

Supervision shall not be included as a line item in the "Cost of the Work", except when the change results in a documented delay in the critical path, as described in Section 7.2.7.
 - 7.2.2.2 Cost of all materials and supplies necessary and required to perform the Work, identifying each item and its individual cost, including taxes. Incidental consumables are not eligible costs and shall not be included.
 - 7.2.2.3 Cost of each necessary piece of machinery and equipment required to perform the Work, identifying each item and its individual cost, including taxes. Incidental small tools of a specific trade (i.e., shovels, saws, hammers, air compressors, etc.,) and general use vehicles, such as pickup trucks even for moving items around the site, fuel for these general use vehicles, travel, lodging, and/or meals are not eligible and shall not be included.
 - 7.2.2.4 Eligible Insurance costs shall be limited to documented increases in "Builder's Risk" insurance

premium / costs only. Commercial General Liability, Automobile Liability, and all other required insurances, where referenced in the Contract shall be considered part of normal overhead. These costs are already compensated by the Overhead and Profit markup.

- 7.2.2.5 Cost for the General Contractor Performance and Payment Bond premium, where the documented cost of the premiums have been increased due to the Change Order.
- 7.2.3 Overhead and Profit - The Contractor and Subcontractor shall be due home office fixed overhead and profits on the Cost of the Work but shall not exceed a total of 16% of the direct cost of any portion of Work. The credit to the Owner resulting from a change in the Work shall be the sum of those items above, except credit will not be required for Overhead and Profit. Where a change results in both credits to the Owner and extras to the Contractor for related items, overhead and profit shall only be computed on the net extra cost to the Contractor.
- 7.2.4 The cost to the Owner resulting from a change in the Work shall be the sum of: Cost of the Work (as defined at Section 7.2.2) and Overhead and Profit (as defined at Section 7.2.3), and shall be computed as follows:
- 7.2.4.1 When all of the Work is General Contractor Work; 8% markup on the Cost of the Work.
- 7.2.4.2 When the Work is all Subcontract Work; 8% markup on the Cost of the Work for Subcontractor's Overhead and Profit, plus 8% markup on the Cost of the Work, not including the Subcontractor's Overhead and Profit markup, for General Contractor's Overhead and Profit.
- 7.2.4.3 When the Work is a combination of General Contractor Work and Subcontract Work; that portion of the direct cost that is General Contract Work shall be computed per Section 7.2.4.1 and that portion of the direct cost that is Subcontract Work shall be computed per Section 7.2.4.2.
- Premiums for the General Contractor's bond may be included, but after the markup is added to the Cost of the Work.
Premiums for the Subcontractor's Bond shall not be included.
- 7.2.4.4 Subcontract cost shall consist of the items in Section 7.2.2 above plus Overhead and Profit as defined in Section 7.2.3.
- 7.2.5 Before a Change Order is prepared, the Contractor shall prepare and deliver to the Architect the following information concerning the Cost of the Work, not subject to waiver, within a reasonable time after being notified to prepare said Change Order:
- A detailed, itemized list of labor, material and equipment costs for the General Contractor's Work including quantities and unit costs for each item of labor, material and equipment.
- An itemized list of labor, material and equipment costs for each Subcontractor's and/or Sub-Subcontractor's Work including quantities and unit costs for each item of labor, material and equipment.
- 7.2.6 After a Change Order has been approved, no future requests for extensions of time or additional cost shall be considered for that Change Order.
- 7.2.7 Extended fixed job-site costs are indirect costs that are necessary to support the work in the field. Examples of fixed job-site costs are field office rental, salaries of field office staff, field office utilities and telephone.
- Extended fixed job-site costs or equitable adjustment, may be included in a Change Order due to a delay in the critical path, with the exception of weather related delays. In the event of a delay in the critical path, the Contractor shall submit all changes or adjustments to the Contract Time within twenty-one (21) days

of the event giving rise to the delay. The Contractor shall submit documentation and justification for the adjustment by performing a critical path analysis of its most recent schedule in use prior to the change, which shows an extension in critical path activities.

The Contractor shall notify the Architect in writing that the Contractor is making a claim for extended fixed job-site overhead as required by Section 15.1.2. The Contractor shall provide proof that the Contractor is unable to mitigate financial damages through Alternate Work within this Contract or replacement work. "Replacement Work" is that work which the Contractor is obligated to perform under any construction contract separate from this Contract. Reasonable proof shall be required by the Architect that the delays affected the Completion Date.

- 7.2.8 "Cost of the Work" whether General Contractor cost or Subcontractor cost shall not apply to the following:
- 7.2.8.1 Salaries or other compensation of the Contractor's personnel at the Contractor's principal office and branch offices.
 - 7.2.8.2 Any part of the Contractor's capital expenses, including interest on the Contractor's capital employed for the Work.
 - 7.2.8.3 Overhead and general expenses of any kind or the cost of any item not specifically and expressly included above in Cost of the Work.
 - 7.2.8.4 Cost of supervision, refer to section 7.2.2.1, with exception as provided in Section 7.2.7.
- 7.2.9 When applicable as provided by the Contract, the cost to Owner for Change Orders shall be determined by quantities and unit prices. The quantity of any item shall be as submitted by the Contractor and approved by the Architect. Unit prices shall cover cost of Material, Labor, Equipment, Overhead and Profit.
- 7.3 CONSTRUCTION CHANGE DIRECTIVES
- 7.3.3 In the first sentence after "following methods" insert: ", but not to exceed a specified amount".
- 7.3.4 From .1 of the list, delete all after "Costs of labor, including" and substitute the following "social security, old age and employment insurance, applicable payroll taxes, and workers' compensation insurance;"
- Delete the following from .4 of the list: "permit fees,"
- Delete Section 7.3.9 and substitute the following:
- 7.3.9 Pending final determination of the total costs of a Construction Change Directive to the Owner, amounts not in dispute for such changes in the Work shall be included in Applications for Payment accompanied by a Change Order indicating the parties' agreement with part or all of such costs.

ARTICLE 8 TIME

- 8.1 DEFINITIONS
Add the following:

8.1.5 The Contract Time shall not be changed by the submission of a schedule that shows an early completion date unless specifically authorized by change order.

- 8.2 PROGRESS AND COMPLETION

Add to Section 8.2.1 the following:

Completion of the Work must be within the Time for Completion stated in the Agreement, subject to such

extensions as may be granted under Section 8.3. The Contractor agrees to commence Work not later than fourteen (14) days after the transmittal date of Written Notice to Proceed from the Owner and to substantially complete the Project within the time stated in the Contract. The Owner will suffer financial loss if the Project is not substantially complete in the time set forth in the Contract Documents. The Contractor and the Contractor's Surety shall be liable for and shall pay to the Owner the sum stated in the Contract Documents as fixed, agreed and liquidated damages for each consecutive calendar day (Saturdays, Sundays and holidays included) of delay until the Work is substantially complete. The Owner shall be entitled to the sum stated in the Contract Documents. Such Liquidated Damages shall be withheld by the Owner from the amounts due the Contractor for progress payments.

Delete Section 8.2.2.

8.3 DELAYS AND EXTENSIONS OF TIME

8.3.1 In the first sentence after the words "Owner pending" delete the words "mediation and binding dispute resolution" and add the word "litigation", and delete the last word "determine" and add the following: "recommend, subject to Owner's approval of Change Order. If the claim is not made within the limits of Article 15, all rights for future claims for that month are waived."

ARTICLE 9

PAYMENTS AND COMPLETION

9.1 CONTRACT SUM

Delete Section 9.1.2.

Delete Section 9.2 and substitute the following:

9.2 SCHEDULE OF VALUES

At the Pre-Construction Conference, the Contractor shall submit to the Owner and the Architect a Schedule of Values prepared as follows:

- 9.2.1 The attached Schedule of Values Format shall be used. If applicable, the cost of Work for each section listed under each division, shall be given. The cost for each section shall include Labor, Materials, Overhead and Profit.
- 9.2.2 The Total of all items shall equal the Total Contract Sum. This schedule, when approved by the Architect, shall be used as a basis for the Contractor's Applications for Payment and it may be used for determining the cost of the Work in deductive change orders, when a specific item of Work listed on the Schedule of Values is to be removed. Once the Schedule of Values is submitted at the Pre-Construction Conference, the schedule shall not be modified without approval from the Owner and Architect.

9.3 APPLICATIONS FOR PAYMENT

Delete Sections 9.3.1, 9.3.1.1, and 9.3.1.2 and substitute the following:

9.3.1 Monthly, the Contractor shall submit to the Architect an Application & Certificate for Payment on the AIA Document G702-1992, accompanied by AIA Document G703-1992, and supported by any additional data substantiating the Contractor's right to payment as the Owner or the Architect may require. Application for Payment shall be submitted on or about the first of each month for the value of labor and materials incorporated into the Work and of materials, suitably stored, at the site as of the twenty-fifth day of the preceding month, less normal retainage as follows, per La R.S. 38:2248:

9.3.1.1 Projects with Contract price up to \$500,000.00 – 10% of the Contract price.

9.3.1.2 Projects with Contract price of \$500,000.00, or more –5% of the Contract price.

9.3.1.3 No payment shall be made until the revised schedule required by Section 3.10.1 is received.

9.3.1.4 The normal retainage shall not be due the Contractor until after substantial completion and

expiration of the forty-five day lien period and submission to the Architect of a clear lien certificate, consent of surety, and invoice for retainage.

Delete Section 9.3.2 and substitute the following:

9.3.2 Unless otherwise provided in the Contract Documents, payments shall be made on account of materials and equipment delivered and suitably stored at the site for subsequent incorporation in the Work. Payments for materials or equipment stored on the site shall be conditioned upon submission by the Contractor of bills of sale or such other procedures satisfactory to the Owner to establish the Owner's title to such materials and equipment or otherwise protect the Owner's interest, including applicable insurance.

9.5 DECISIONS TO WITHHOLD CERTIFICATION

Section 9.5.1.7: Delete the word "repeated".

Delete Section 9.5.4.

9.6 PROGRESS PAYMENTS

Delete Section 9.6.1 and substitute the following:

9.6.1 After the Architect has issued a Certificate for Payment, the Owner shall make payment within twenty days except for Projects funded fully or in part by a Federal reimbursement program. For such Projects the Owner will make payment in a timely manner consistent with reimbursement.

9.6.2 Delete the phrase: "no later than seven days" from the first sentence.

After the end of the second sentence, add the following:

La R.S. 9:2784 (A) and (C) require a Contractor or Subcontractor to make payment due to each Subcontractor and supplier within fourteen (14) consecutive days of the receipt of payment from the Owner. If not paid, a penalty in the amount of ½ of 1% per day is due, up to a maximum of 15% from the expiration date until paid. The contractor or subcontractor, whichever is applicable, is solely responsible for payment of a penalty.

9.6.4 Delete the first two sentences of Section 9.6.4 and add the following to the end of the Section:

Pursuant to La. R.S. 38:2242 and La. R.S. 38:2242.2, when the Owner receives any claim of nonpayment arising out of the Contract, the Owner shall deduct 125% of such claim from the Contract Sum. The Contractor, or any interested party, may deposit security, in accordance with La. R.S. 38:2242.2, guaranteeing payment of the claim with the recorder of mortgages of the parish where the Work has been done. When the Owner receives original proof of such guarantee from the recorder of mortgages, the claim deduction will be added back to the Contract Sum.

Delete Section 9.7 FAILURE OF PAYMENT.

Delete Section 9.8 and substitute the following:

9.8 SUBSTANTIAL COMPLETION

9.8.1 Substantial Completion is the stage in the progress of the Work when the Work is sufficiently complete in accordance with the Contract Documents so that the Owner can occupy or utilize the Work for its intended use. The Architect shall determine if the Project is substantially complete in accordance with this Section.

9.8.2 When the Contractor considers that the Work is Substantially Complete, the Contractor shall prepare and submit to the Architect a comprehensive list of items to be completed or corrected prior to final

payment. Failure to include an item on such list does not alter the responsibility of the Contractor to complete all Work in accordance with the Contract Documents.

- 9.8.3 Upon receipt of the Contractor's list, the Architect shall make an inspection to determine whether the Work is substantially complete. A prerequisite to the Work being considered as substantially complete is the Owner's receipt of the executed Roofing Contractor's and Roofing Manufacturer's guarantees, where roofing Work is part of the Contract. Prior to inspection by the Architect, the Contractor shall notify the Architect that the Project is ready for inspection by the State Fire Marshal's office. If the Architect's inspection discloses any item, whether or not included on the Contractor's list, which is not sufficiently complete in accordance with the Contract Documents so that the Owner can occupy or utilize the Work for its intended use, the Contractor shall, before the Work can be considered as Substantially Complete, complete, or correct such item upon notification by the Architect. In such case, the Contractor shall then submit a request for another inspection by the Architect to determine Substantial Completion.
- 9.8.4 When the Architect determines that the Project is Substantially Complete, he shall prepare a punch list of exceptions and the dollar value related thereto. The monetary value assigned to this list will be the sum of the cost estimate for each particular item of Work the Architect develops based on the mobilization, labor, material, and equipment costs of correcting the item and shall be retained from the monies owed the contractor, above and beyond the standard lien retainage. The cost of these items shall be prepared in the same format as the schedule of values. At the end of the forty-five day lien period payment shall be approved for all punch list items completed up to that time. After that payment, none of the remaining funds shall be due the contractor until all punch list items are completed and are accepted by the Architect. If the dollar value of the punch list exceeds the amount of funds, less the retainage amount, in the remaining balance of the Contract, then the Project shall not be considered as substantially complete. If funds remaining are less than that required to complete the Work, the Contractor shall pay the difference.
- 9.8.5 When the preparation of the punch list is complete the Architect shall prepare a Recommendation of Acceptance incorporating the punch list and submit it to the Owner. Upon approval of the Recommendation of Acceptance, the Owner may issue a Notice of Acceptance of Building Contract which shall establish the Date of Substantial Completion. The Contractor shall record the Notice of Acceptance with the Clerk of Court in the Parish in which the Work has been performed. If the Notice of Acceptance has not been recorded seven (7) days after issuance, the Owner may record the Acceptance at the Contractor's expense. All additive change orders must be processed before issuance of the Recommendation of Acceptance. The Owner shall not be responsible for payment for any Work associated with change orders that is not incorporated into the contract at the time of the Recommendation of Acceptance.
- 9.8.6 Warranties required by the Contract Documents shall commence on the date of Acceptance of the Work unless otherwise agreed to in writing by the Owner and Contractor. Unless otherwise agreed to in writing by the Owner and Contractor, security, maintenance, heat, utilities, damage to the Work not covered by the punch list and insurance shall become the Owner's responsibility on the Date of Substantial Completion.
- 9.8.7 If all punch list items have not been completed by the end of the forty-five (45) day lien period, through no fault of the Architect or Owner, the Owner may hold the Contractor in default. If the Owner finds the Contractor is in default, the Surety shall be notified. If within forty-five (45) days after notification, the Surety has not completed the punch list, through no fault of the Architect or Owner, the Owner may, at his option, contract to have the balance of the Work completed and pay for such Work with the unpaid funds remaining in the Contract sum. Finding the Contractor in default shall constitute a reason for disqualification of the Contractor from bidding on future state contracts. If the surety fails to complete the punch list within the stipulated time period, the Owner may not accept bonds submitted, in the future, by the surety.

9.9 PARTIAL OCCUPANCY OR USE

Delete Section 9.9.1 and substitute the following:

9.9.1 Partial Occupancy is that stage in the progress of the Work when a designated portion of the Work is sufficiently complete in accordance with the Contract Documents so the Owner can occupy or utilize the designated portion of the Work for its intended use. The Owner may occupy or use any substantially completed portion of the Work so designated by separate agreement with the Contractor and authorized by public authorities having jurisdiction over the Work. Such occupancy or use may commence provided the Owner and Contractor have accepted in writing the responsibilities assigned to each of them for payments, if any, security, maintenance, heat, utilities, damage to the Work and insurance, and have agreed in writing concerning the period for correction of the Work and commencement of warranties required by the Contract Documents. When the Contractor considers the designated portion substantially complete the Contractor shall prepare and submit a list to the Architect as provided under Section 9.8.2. Consent of the Contractor to partial occupancy or use shall not be unreasonably withheld.

9.10 FINAL COMPLETION AND FINAL PAYMENT

9.10.1 After the second sentence, add the following:

If the Architect does not find the Work acceptable under the Contract Documents, the Architect shall make one additional inspection; if the Work is still not acceptable, the Architect, and each of the Architect's principal consultants, shall be paid \$175.00/hour for their time at the Project site, for each additional inspection, to be withheld from the unpaid funds remaining in the Contract sum. The payment shall be made by the Owner and deducted from the construction contract funds.

Delete Section 9.10.4 and replace with the following:

9.10.4 The making of final payment shall not constitute a waiver of Claims by the Owner for the following:

9.10.4.1 Claims, security interests, or encumbrances arising out of the Contract and unsettled;

9.10.4.2 failure of the Work to comply with the requirements of the Contract Documents irrespective of when such failure is discovered;

9.10.4.3 terms of special warranties required by the Contract Documents; or

9.10.4.4 audits performed by the Owner, after final payment.

ARTICLE 10

PROTECTION OF PERSONS AND PROPERTY

10.2 SAFETY OF PERSONS AND PROPERTY

10.2.2 In the first sentence, between the words: "bearing on" and "safety", add the words: "the health and,"

10.3 HAZARDOUS MATERIALS

10.3.1 In the second sentence after (PCB) add: "or lead".

10.3.2 After the first sentence, delete all remaining sentences.

Add at the end: "The Contract time shall be extended appropriately."

Delete Section 10.4 and substitute the following:

10.4 EMERGENCIES

In an emergency affecting the safety of persons or property, the Contractor shall notify the Owner and Architect immediately of the emergency, simultaneously acting at his discretion to prevent damage, injury or loss. Any additional compensation or extension of time claimed by the Contractor on account of emergency Work shall be determined as provided in Article 15 and Article 7.

ARTICLE 11

INSURANCE AND BONDS

AIA A101 – 2017 Exhibit A is not a part of these documents. Delete all of Sections 11.1, 11.2, 11.3, 11.4, and 11.5, and substitute the following:

INSURANCE REQUIREMENTS FOR NEW CONSTRUCTION, ADDITIONS AND RENOVATIONS

11.1 CONTRACTOR'S LIABILITY INSURANCE

The Contractor shall purchase and maintain without interruption for the duration of the contract insurance against claims for injuries to persons or damages to property which may arise from or in connection with the performance of the Work hereunder by the Contractor, its agents, representatives, employees or subcontractors. The duration of the contract shall be from the inception of the contract until the date of final payment.

11.2 MINIMUM SCOPE AND LIMITS OF INSURANCE

11.2.1 Worker's Compensation

Worker's Compensation insurance shall be in compliance with the Worker's Compensation law of the Contractor's headquarters. Employers Liability is included with a minimum limit of \$1,000,000 per accident/per disease/per employee. If Work is to be performed over water and involves maritime exposure, applicable LHWCA, Jones Act or other maritime law coverage shall be included. A.M. Best's insurance company rating requirement may be waived for Worker's compensation coverage only.

11.2.2 Commercial General Liability

Commercial General Liability insurance, including Personal and Advertising Injury Liability and Products and Completed Operations Liability, shall have a minimum limit per occurrence based on the Project value. The Insurance Services Office (ISO) Commercial General Liability occurrence coverage form CG 00 01 (current form approved for use in Louisiana), or equivalent, is to be used in the policy. Claims-made form is unacceptable.

The aggregate loss limit must apply to each Project. ISO form CG 25 03 (current form approved for use in Louisiana), or equivalent, shall also be submitted. The State Project number, including part number, and Project name shall be included on this endorsement.

COMBINED SINGLE LIMIT (CSL) PER OCCURRENCE

Type of Construction	Projects up to \$1,000,000	Projects over \$1,000,000 up to \$50,000,000	Projects over \$50,000,000
New Buildings:			
Each Occurrence			
Minimum Limit	\$1,000,000	\$2,000,000	\$4,000,000
Per Project Aggregate	\$2,000,000	\$4,000,000	\$8,000,000
Renovations:	The building(s) value for the Project is \$_____.		
Each Occurrence			
Minimum Limit	\$1,000,000**	\$2,000,000**	\$4,000,000**
Per Project Aggregate	2 times per	2 times per	2 times per

occur limit**

occur limit**

occur limit**

**While the minimum Combined Single Limit of \$1,000,000 is required for any renovation, the limit is calculated by taking 10% of the building value and rounding it to the nearest \$1,000,000 to get the insurance limit. Example: Renovation on a \$33,000,000 building would have a calculated \$3,000,000 combined single limit of coverage (33,000,000 times .10 = 3,300,000 and then rounding down to \$3,000,000). If the calculated limit is less than the minimum limit listed in the above chart, then the amount needed is the minimum listed in the chart. Maximum per occurrence limit required is \$50,000,000 regardless of building value. The per Project aggregate limit is then calculated as twice the per occurrence limit.

11.2.3 Automobile Liability

Automobile Liability Insurance shall have a minimum combined single limit per occurrence of \$1,000,000. ISO form number CA 00 01 (current form approved for use in Louisiana), or equivalent, is to be used in the policy. This insurance shall include third-party bodily injury and property damage liability for owned, hired and non-owned Automobiles.

11.2.4 Excess Umbrella

Excess Umbrella Insurance may be used to meet the minimum requirements for General Liability and Automobile Liability only.

11.2.5 Builder's Risk

11.2.5.1 Builder's Risk Insurance shall be in an amount equal to the amount of the construction contract including any amendments and shall be upon the entire Work included in the contract. The policy shall provide coverage equivalent to the ISO form number CP 10 20, Broad Form Causes of Loss (extended, if necessary, to include the perils of wind, earthquake, collapse, vandalism/malicious mischief, and theft, including theft of materials whether or not attached to any structure). The policy must include architects' and engineers' fees necessary to provide plans, specifications and supervision of Work for the repair and/or replacement of property damage caused by a covered peril, not to exceed 10% of the cost of the repair and/or replacement.

11.2.5.2 Flood coverage shall be provided by the Contractor on the first floor and below for all Projects, except as otherwise noted. The builder's risk insurance policy, sub-limit for flood coverage shall not be less than ten percent (10%) of the total contract cost per occurrence. If flood is purchased as a separate policy, the limit shall be ten percent (10%) of the total contract cost per occurrence (with a max of \$500,000 if NFIP). Coverage for roofing Projects shall not require flood coverage.

11.2.5.3 A Specialty Contractor may provide an installation floater in lieu of a Builder's Risk policy, with the similar coverage as the Builder's Risk policy, upon the system to be installed in an amount equal to the amount of the contract including any amendments. Flood coverage is not required.

11.2.5.4 The policy must include coverage for the Owner, Contractor and any subcontractors as their interests may appear.

11.2.6 Pollution Liability (*required when asbestos or other hazardous material abatement is included in the contract*)

Pollution Liability insurance, including gradual release as well as sudden and accidental, shall have a minimum limit of not less than \$1,000,000 per claim. A claims-made form will be acceptable. A policy period inception date of no later than the first day of anticipated Work under this contract and an expiration date of no earlier than 30 days after anticipated completion of all Work under the contract shall be provided. There shall be an extended reporting period of at least 24 months, with full reinstatement of limits, from the expiration date of the policy if the policy is not renewed. The policy shall not be cancelled for any reason, except non-payment of premium.

11.2.7 Deductibles and Self-Insured Retentions

Any deductibles or self-insured retentions must be declared to and accepted by the Owner. The Contractor shall be responsible for all deductibles and self-insured retentions.

11.3 OTHER INSURANCE PROVISIONS

11.3.1 The policies are to contain, or be endorsed to contain, the following provisions:

11.3.1.1 Worker's Compensation and Employers Liability Coverage

11.3.1.1.1 To the fullest allowed by law, the insurer shall agree to waive all rights of subrogation against the Owner, its officers, agents, employees and volunteers for losses arising from Work performed by the Contractor for the Owner.

11.3.1.2 Commercial General Liability Coverage

11.3.1.2.1 The Owner, its officers, agents, employees and volunteers are to be added as additional insureds as respects liability arising out of activities performed by or on behalf of the Contractor; products and completed operations of the Contractor, premises owned, occupied or used by the Contractor. ISO Form CG 20 10 (for ongoing work) AND CG 20 37 (for completed work) (current forms approved for use in Louisiana), or equivalent, are to be used.

11.3.1.2.2 The Contractor's insurance shall be primary as respects the Owner, its officers, agents, employees and volunteers for any and all losses that occur under the contract. The coverage shall contain no special limitations on the scope of protection afforded to the Owner, its officers, officials, employees or volunteers. Any insurance or self-insurance maintained by the Owner shall be excess and non-contributory of the Contractor's insurance.

11.3.1.3 Builder's Risk

The policy must include an endorsement providing the following:

In the event of a disagreement regarding a loss covered by this policy, which may also be covered by a State of Louisiana self-insurance or commercial property policy through the Office of Risk Management (ORM), Contractor and its insurer agree to follow the following procedure to establish coverage and/or the amount of loss:

Any party to a loss may make written demand for an appraisal of the matter in disagreement. Within 20 days of receipt of written demand, the Contractor's insurer and either ORM or its commercial insurance company shall each select a competent and impartial appraiser and notify the other of the appraiser selected. The two appraisers shall select a competent and impartial umpire. The appraisers shall then identify the policy or policies under which the loss is insured and, if necessary, state separately the value of the property and the amount of the loss that must be borne by each policy. If the two appraisers fail to agree, they shall submit their differences to the umpire. A written decision by any two shall determine the policy or policies and the amount of the loss. Each insurance company agrees that the decision of the appraisers and the umpire if involved shall be binding and final and that neither party will resort to litigation. Each of the two parties shall pay its chosen appraiser and bear the cost of the umpire equally.

11.3.1.4 All Coverages

11.3.1.4.1 All policies must be endorsed to require 30 days written notice of cancellation to the Agency. Ten-day written notice of cancellation is acceptable for non-payment of premium. Notifications shall comply with the standard cancellation provisions in the Contractor's policy. In addition, Contractor is required to notify Agency of policy cancellations or reductions in limits.

11.3.1.4.2 Neither the acceptance of the completed Work nor the payment thereof shall release the Contractor from the obligations of the insurance requirements or indemnification agreement.

11.3.1.4.3 The insurance companies issuing the policies shall have no recourse against the Owner for payment of premiums or for assessments under any form of the policies.

11.3.1.4.4 Any failure of the Contractor to comply with reporting provisions of the policy shall not affect coverage provided to the Owner, its officers, agents, employees and volunteers.

11.3.2 Acceptability of Insurers

All required insurance shall be provided by a company or companies lawfully authorized to do business in the jurisdiction in which the Project is located. Insurance shall be placed with insurers with an A.M. Best's rating of A-: VI or higher. This rating requirement may be waived for Worker's compensation coverage only.

If at any time an insurer issuing any such policy does not meet the minimum A.M. Best rating, the Contractor shall obtain a policy with an insurer that meets the A.M. Best rating and shall submit another certificate of insurance within 30 days.

11.3.3 Verification of Coverage

Contractor shall furnish the Owner with Certificates of Insurance reflecting proof of required coverage. The Certificates for each insurance policy are to be signed by a person authorized by that insurer to bind coverage on its behalf. The Certificates are to be received and approved by the Owner before Work commences and upon any contract renewal or insurance policy renewal thereafter. The Certificate Holder must be listed as follows:

State of Louisiana
University of Louisiana at Lafayette
PO Box 40197
Lafayette, LA 70504
Ref: Solicitation File No. _____

The Owner reserves the right to request complete certified copies of all required insurance policies at any time.

Upon failure of the Contractor to furnish, deliver and maintain required insurance, this contract, at the election of the Agency, may be suspended, discontinued, or terminated. Failure of the Contractor to purchase and/or maintain any required insurance shall not relieve the Contractor from any liability or indemnification under the contract.

If the Contractor does not meet the insurance requirements at policy renewal, at the option of the Owner, payment to the Contractor may be withheld until the requirements have been met, OR the Owner may pay the renewal premium and withhold such payment from any monies due the Contractor, OR the contract may be suspended or terminated for cause.

11.3.4 Subcontractors

Contractor shall include all subcontractors as insureds under its policies OR shall be responsible for verifying and maintaining the certificates provided by each subcontractor. Subcontractors shall be subject to all of the requirements stated herein. The Owner reserves the right to request copies of subcontractor's certificates at any time.

If Contractor does not verify subcontractors' insurance as described above, Owner has the right to withhold payments to the Contractor until the requirements have been met.

11.3.5 Worker's Compensation Indemnity

In the event Contractor is not required to provide or elects not to provide Worker's compensation coverage, the parties hereby agree the Contractor, its Owners, agents and employees shall have no cause of action against, and shall not assert a claim against, the state of Louisiana, its departments, agencies, agents and employees as an employer, whether pursuant to the Louisiana Worker's Compensation Act or otherwise, under any circumstance. The parties also hereby agree that the State of Louisiana, its departments, agencies, agents and employees shall in no circumstance be, or considered as, the employer or statutory employer of Contractor, its Owners, agents and employees. The parties further agree that Contractor is a wholly independent Contractor and is exclusively responsible for its employees, Owners, and agents. Contractor hereby agrees to protect, defend, indemnify and hold the State of Louisiana, its departments, agencies, agents and employees harmless from any such assertion or claim that may arise from the performance of this contract.

11.3.6 Indemnification/Hold Harmless Agreement

Contractor agrees to protect, defend, indemnify, save, and hold harmless, the State of Louisiana, all State Departments, Agencies, Boards and Commissions, its officers, agents, servants, employees and volunteers, from and against any and all claims, damages, expenses and liability arising out of injury or death to any person or the damage, loss or destruction of any property which may occur, or in any way grow out of, any act or omission of Contractor, its agents, servants and employees, or any and all costs, expenses and/or attorney fees incurred by Contractor as a result of any claims, demands, suits or causes of action, except those claims, demands, suits or causes of action arising out of the negligence of the State of Louisiana, all State Departments, Agencies, Boards, Commissions, its officers, agents, servants, employees and volunteers.

Contractor agrees to investigate, handle, respond to, provide defense for and defend any such claims, demands, suits or causes of action at its sole expense and agrees to bear all other costs and expenses related thereto, even if the claims, demands, suits, or causes of action are groundless, false or fraudulent. The State of Louisiana may, but is not required to, consult with the Contractor in the defense of claims, but this shall not affect the Contractor's responsibility for the handling and expenses of all claims.

11.4 PERFORMANCE AND PAYMENT BOND

11.4.1 The Owner shall have the right to require the Contractor to furnish bonds covering faithful performance of the Contract and payment of obligations arising thereunder as stipulated in bidding requirements or specifically required in the Contract Documents on the date of execution of the Contract.

11.4.2 Upon the request of any person or entity appearing to be a potential beneficiary of bonds covering payment of obligations arising under the Contract, the Contractor shall promptly furnish a copy of the bonds or shall authorize a copy to be furnished.

11.4.3 Recordation of Contract and Bond [La R.S. 38:2241 thru 38:2241.1]

The Owner shall require the Contractor to record within thirty (30) days the Contract Between Owner and Contractor and Performance and Payment Bond with the Clerk of Court in the Parish in which the Work is to be performed.

ARTICLE 12

UNCOVERING AND CORRECTION OF WORK

12.2 CORRECTION OF WORK

12.2.1 Before Substantial Completion

At the end of the paragraph, add the following sentences:

“If the Contractor fails to correct Work identified as defective within a thirty (30) day period, through no fault of the Designer, the Owner may hold the Contractor in default. If the Owner finds the Contractor in default, the Surety shall be notified. If within thirty (30) days after notification, the Surety has not corrected the nonconforming Work, through no fault of the Architect or Owner, the Owner may contract to have nonconforming Work corrected and hold the Surety and Contractor responsible for the cost, including architectural fees and other indirect costs. If the Surety fails to correct the Work within the stipulated time period and fails to meet its obligation to pay the costs, the Owner may elect not to accept bonds submitted in the future by the Surety. Finding the Contractor in default shall constitute a reason for disqualification of the Contractor from bidding on future state contracts.

12.2.2 After Substantial Completion

12.2.2.1 At the end of the paragraph delete the last sentence and add the following sentences:

“If the Contractor fails to correct nonconforming Work, or Work covered by warranties, within a thirty (30) day period, through no fault of the Architect or Owner, the Owner may hold the Contractor in default. If the Owner finds the Contractor is in default, the Surety shall be notified. If within thirty (30) days after notification, the Surety has not corrected the non-conforming or warranty Work, through no fault of the Architect or Owner, the Owner may contract to have the nonconforming or warranty Work corrected and hold the Surety responsible for the cost including architects fees and other indirect costs. Corrections by the Owner shall be in accordance with Section 2.4. If the Surety fails to correct the nonconforming or warranty Work within the stipulated time period and fails to meet its obligation to pay the costs, the Owner may not accept bonds submitted, in the future, by the Surety.”

ARTICLE 13

MISCELLANEOUS PROVISIONS

13.1 GOVERNING LAW

Delete all after the word “located”.

13.2 SUCCESSORS AND ASSIGNS

13.2.1 In the second sentence, delete “Except as ... 13.2.2”

Delete Section 13.2.2.

13.3 RIGHTS AND REMEDIES

Add the following Section 13.3.3:

13.3.3 The Nineteenth Judicial Court in and for the Parish of East Baton Rouge, State of Louisiana shall have sole jurisdiction and venue in any action brought under this contract.

13.4 TESTS AND INSPECTIONS

In Section 13.4.1, delete the second sentence and substitute the following:

The Contractor shall make arrangements for such tests, inspections and approvals with the Testing Laboratory provided by the Owner, and the Owner shall bear all related costs of tests, inspections and approvals.

Delete the last two sentences of Section 13.4.1.

13.5 INTEREST

Delete Section 13.5.

ARTICLE 14

TERMINATION OR SUSPENSION OF THE CONTRACT

14.1 TERMINATION BY THE CONTRACTOR

Delete Section 14.1.1.4.

In Section 14.1.3, after the word “profit,” delete the words “on Work not executed” and substitute the following: “for Work completed prior to stoppage”.

14.2 TERMINATION BY THE OWNER FOR CAUSE

Add the following Section:

14.2.1.5 failure to complete the punch list within the lien period as provided in 9.8.7.

14.2.3 Add the following sentence:

“Termination by the Owner shall not suspend assessment of liquidated damages against the Surety.”

Add the following Section:

14.2.5 If an agreed sum of liquidated damages has been established, termination by the Owner under this Article shall not relieve the Contractor and/or Surety of his obligations under the liquidated damages provisions and the Contractor and/or Surety shall be liable to the Owner for per diem liquidated damages.

14.4 TERMINATION BY THE OWNER FOR CONVENIENCE

In Section 14.4.3, delete all after “incurred by reason of the termination,” and add “along with reasonable profit on the Work not executed.”

ARTICLE 15 CLAIMS AND DISPUTES

15.1 CLAIMS

Delete Section 15.1.2, Time Limit on Claims, (See La R.S. 38:2189, and 38:2189.1).

15.1.3.1 Add the following to the end of the paragraph:

“A Reservation of Rights and similar stipulations shall not be recognized under this contract as having any effect. A party must make a claim as defined herein within the time limits provided.”

15.1.4.2 In the first sentence of the Section, delete “Initial Decision Maker’s” and replace with “Architect’s”. In the second sentence of the Section, delete “the decision of the Initial Decision Maker” and replace with: “his/her decision”.

Delete Section 15.1.6.2 and substitute the following:

15.1.6.2 If adverse weather conditions are the basis for a claim for additional time, the Contractor shall document that weather conditions had an adverse effect on the scheduled construction. An increase in the contract time due to weather shall not be cause for an increase in the contract sum. At the end of each month, the Contractor shall make one Claim for any adverse weather days occurring within the month. The Claim must be accompanied by sufficient documentation evidencing the adverse days and the impact on construction. Failure to make such Claim within twenty-one (21) days from the last day of the month shall prohibit any future claims for adverse days for that month. No additional adverse weather days shall be granted after the original or extended contract completion date, except those adverse weather days associated with a National Weather Service named storm or federally declared weather related disaster directly affecting the Project site.

Add the following Section:

15.1.6.3 The following are considered reasonably anticipated days of adverse weather on a monthly basis:

January	<u>11</u> days	July	<u>6</u> days
February	<u>10</u> days	August	<u>5</u> days
March	<u>8</u> days	September	<u>4</u> days
April	<u>7</u> days	October	<u>3</u> days
May	<u>5</u> days	November	<u>5</u> days
June	<u>6</u> days	December	<u>8</u> days

The Contractor shall ask for total adverse weather days. The Contractor’s request shall be considered only for days over the allowable number of days stated above.

Note: Contract is on a calendar day basis.

15.2 INITIAL DECISION

15.2.1 In the second sentence, delete the word “will” and replace with: “shall always”.

In the second sentence, delete the phrase: “, unless otherwise indicated in the Agreement.”

In the third sentence, delete the word “mediation” and replace with: “litigation”.

At the end of the third sentence, add: “arising prior to the date final payment is due”.

Delete the fourth sentence.

15.2.5 In the middle of the first sentence, delete all after the phrase: “rejecting the Claim”.

In the second sentence, delete the phrase: “and the Architect, if the Architect is not serving as the Initial Decision Maker,”.

In the third sentence, delete all after: “binding on the parties” and add the following: “except that the Owner may reject the decision or suggest a compromise or both”.

Delete Section 15.2.6.

Delete Section 15.2.6.1.

15.3 MEDIATION

Delete Section 15.3.

15.4 ARBITRATION

Delete Section 15.4.

END OF SECTION

INSURANCE REQUIREMENTS

Contractor shall purchase, at its own cost and expense, and maintain for the duration of the Contract, insurance against claims for injuries to persons or damages to property which may arise from or in connection with the performance of the work hereunder by Contractor, its agents, representatives, employees, or subcontractors. The insurance shall be obtained from a company or companies lawfully authorized to do business in the State of Louisiana with a A.M. Best's rating of A-VI or higher. Failure to comply with all terms of this section for the duration of the Contract places Contractor in breach of this Contract.

A. Minimum Scope of Insurance and Limits**1. Workers Compensation**

Contractor shall be in compliance at all times with the Louisiana Workers' Compensation Law with respect to workers' compensation insurance or proper certification of self-insured status.

2. Commercial General Liability

Contractor shall maintain Commercial General Liability insurance, including Personal and Advertising Injury Liability, which coverage shall have a minimum limit per occurrence of \$1,000,000 and a minimum general aggregate of \$2,000,000. The Insurance Services Office (ISO) Commercial General Liability occurrence coverage form CG 00 01 (current form approved for use in Louisiana), or equivalent, is to be used in the policy. Claims-made form is unacceptable.

Additionally, if alcohol is served in the execution of this Contract, then Contractor shall maintain Liquor Liability coverage in the minimum amount of \$1,000,000 per occurrence.

Additionally, if valet parking is performed in the execution of this Contract, then Contractor shall maintain Garage Keepers Liability coverage in the minimum amount of \$1,000,000 per occurrence.

3. Automobile Liability

If a motor vehicle owned, hired, or rented by the Contractor is used in the performance of the Contract, Contractor shall maintain Automobile Liability Insurance, which coverage shall have a minimum combined single limit per occurrence of \$1,000,000. ISO form number CA 00 01 (current form approved for use in Louisiana), or equivalent, is to be used in the policy. This insurance shall include third-party bodily injury and property damage liability for owned, hired, and non-owned automobiles.

4. Professional Liability, Errors and Omissions, and Malpractice Insurance

If any of the following professionals provide services in the execution of the Contract, Contractor shall purchase and maintain Professional Liability Insurance, which coverage shall have minimum limits of \$1,000,000:

1. Medical Professionals, such as physicians, nurses, dentists, and pharmacists;
2. Architects and Engineers;
3. Attorneys;
4. Accountants and Professional Financial Advisors;
5. Real Estate Brokers and Appraisers;
6. Insurance Agents; and
7. Consultants.

Claims-made coverage for Professional Liability Insurance is acceptable. The date of the inception of the policy must be no later than the first date of the anticipated work under this Contract. It shall provide coverage for the duration of this Contract and shall have an expiration date no earlier than 30 days after the anticipated completion of the Contract. The policy shall provide an extended reporting period of at least 24 months, with full reinstatement of limits, from the expiration date of the policy, if policy is not renewed.

5. Cyber Liability Insurance

For Contracts in which the Contractor shall be granted access to electronic data belonging to the University or others, including but not limited to corporate confidential information (CCI), personal financial information (PII), personal health information (PHI), payment card information (PCI), and all personal student information (PSI) stored in electronic format, and for which there is a risk of electronic security breaches of this confidential data, including inadvertent release, hacking, viruses, improper destruction, etc., Cyber Liability insurance, including first-party costs, shall be required with a minimum limit per occurrence of \$1,000,000. Claims-made coverage is acceptable. The date of the inception of the policy must be no later than the first date of the anticipated work under this Contract. It shall provide coverage for the duration of this Contract and shall have an expiration date no earlier than 30 days after the anticipated completion of the Contract. The policy shall provide an extended reporting period of not less than 36 months from the expiration date of the policy, if the policy is not renewed. The policy shall not be cancelled for any reason, except non-payment of premium.

B. Other Insurance Provisions

Contractor shall either (i) require each subcontractor and vendor to procure and maintain all applicable insurance of the type and limits specified herein, or (ii) include all subcontractors as insureds under its policies.

Any deductibles or self-insured retentions must be declared to and accepted by University. Contractor shall be responsible for all deductibles and self-insured retentions. Any insurance or self-insurance maintained by University shall be excess and non-contributory of Contractor's insurance. Contractor's coverage shall contain no special limitations on the scope of protection afforded to University. Contractor's insurance shall be primary as respects

University, The Board of Supervisors for the University of Louisiana System ("Board"), and all of their respective officers, agents, employees, and volunteers.

Except for workers' compensation coverage, University and Board, and all of their respective officers, agents, employees, and volunteers, shall be named as an additional insured for the full occurrence and aggregate limits of the applicable insurance policies as regards negligence by Contractor. ISO Form CG 20 10 (current form approved for use in Louisiana), or equivalent, is to be used when applicable.

Contractor shall provide to University Certificates of Insurance ("Certificates") evidencing the foregoing coverage in advance of Contractor's delivery of goods and/or performance of work or services, and in all events, prior to any payment by University to Contractor. In addition to Certificates, Contractor shall submit to University the declarations page and the cancellation provisions for each insurance policy. University reserves the right to request complete certified copies of all required insurance policies at any time.

Certificates and all notices regarding coverage shall be addressed to: University of Louisiana at Lafayette

ATTN: Purchasing Department

P.O. Box 40197 Lafayette, LA 70504

Certificates of Insurance shall reflect that, to the fullest extent allowed by law, the insurer shall agree to waive all rights of subrogation against University, its officers, agents, employees, and volunteers for losses arising from work performed by the Contractor for University.

Coverage shall not be canceled, suspended, reduced, or voided by either Contractor or the insurer except after 30 days written notice has been given to University. Ten-day written notice of cancellation is acceptable for non-payment of premium. Notifications shall comply with the standard cancellation provisions in Contractor's policy.

Acceptance of goods or completed work by University, payment by University, failure of University to require proof of compliance, or University's acceptance of a non-compliant Certificate shall not release Contractor from its obligations under these insurance requirements. Failure of Contractor to purchase and/or maintain any required insurance shall not relieve Contractor from any liability or indemnification required by law or contract.

END OF SECTION

GENERAL REQUIREMENTS

The Contractor shall furnish and install all labor and material necessary to provide and install the complete portion of this contract, including all materials and equipment as shown on the plans. It is the intention of these specifications that all systems be furnished complete with whatever necessary items are required to produce a satisfactory installation in a working order. The Contractor shall be responsible for bringing to the attention of the Owner any shortcomings of the design, or thereby, shall be responsible in full to meet the conditions set forth, that being, the system is to be in a satisfactory working order.

All material shall be installed in accordance with the instructions of the manufacturers. The work shall be done in strict compliance with state and local ordinances governing this class of work. The prospective bidder shall visit the job site and become familiar with all existing conditions found at the site. The Contractor shall become acquainted with all existing factors and conditions which affect the work. Failure to do so shall not relieve meeting the responsibility to install the work correctly.

The Contractor shall protect the entire installation from injury on the Project until final acceptance. Failure to do so shall be sufficient cause for the Agent to reject any work.

CONSTRUCTION FORCE

The Contractor shall provide and maintain in full operation at all times during the performance of the contract a sufficient work crew to execute the work with dispatch. The Contractor shall provide a full time superintendent who shall be on the job during all working periods.

The Contractor shall be responsible for maintenance and repair of all equipment installed by him which fails due to substandard workmanship.

PARKING

Contractor shall be responsible for all fees for temporary campus parking permits. The Facility Management department shall request the permits through the UL Parking and Transit department. Contractor shall be required to display the permit on their vehicles at all times while on campus. Failure to do so may result in parking citation.

DEQ NOTIFICATION

The Contractor shall be responsible for the proper notification of the Department of Environmental Quality whenever demolition work is to be performed. Copies of the DEQ Notification Form AAC-2 and any additional correspondence with DEQ shall be copied to the University.

STANDARDS

All materials furnished under this contract shall be designed, constructed and rated in accordance with the latest applicable standards, and shall pass tests as recommended therein.

WORKMANSHIP AND MATERIALS

The workmanship shall conform to the best accepted construction practice. Should it become evident that during the course of construction that the items indicated on the plans, are for any reason undesirable, the Contractor shall immediately bring the situation to the attention of the Agent for a decision. The Contractor shall be responsible for installing the proper materials as described by the drawings and specifications.

All materials furnished for this Project shall be new, undamaged, and bear the label of the Underwriters' Laboratories, Inc. Deliver materials in manufacturer's original package and store on skids so that the materials are off the ground, and so that product labels are exposed for easy inspection.

The Bidder shall base the proposal on materials herein specified. Reference to specific manufacturers or trade names is not intended to limit or indicate preference to specific manufacturers, but to indicate a standard of quality. Written approval from the Agent is required on all substitutions prior to installations.

GUARANTEE

The Contractor shall guarantee new materials and workmanship for a minimum of one (1) full year after formal acceptance of the Project. The Contractor will replace defective material and repair all workmanship defects promptly, and absorb all costs.

This provision shall not override any other warranties that are specified herein.

CAMPUS SAFETY POLICY

Contractor shall adhere to the campus safety policy. Information regarding campus safety can be found on the UL Lafayette website at: <http://www.louisiana.edu/ehs>

LOUISIANA ONE CALL

UL Lafayette is a member in the Louisiana One Call system. At least 72 hours before digging anywhere on UL Lafayette property the contractor must call 1-800-272-3020 to verify the location of utilities.

EXISTING LANDSCAPING

Contractor is liable for any damages caused to the existing landscaping. All landscaping must be protected from root compaction and other physical damage. Contractor must provide three foot high orange construction fencing around the drip line of all trees within the construction site.

ASBESTOS

The contractor will not be required to interface with any asbestos containing material (ACM) during this Project. The State of Louisiana has conducted an asbestos survey of all buildings on the UL Lafayette campus. The results of the survey are compiled in management plans for each building. The management plans were assembled according to the requirements set forth in the Department of Environmental Quality Required Elements Index. These plans are available for review to anyone interested in the results. The plans are kept on file in the Reserve Reading Room of Edith Garland Dupre' Library.

COORDINATION OF WORK

The Contractor shall inform the Agent each day of his work location before proceeding to work, and each time the Contractor moves into a different area.

STORM WATER RUN OFF PROTECTION

Contractor shall protect the entire construction site from erosion due to storm water run-off. A retention barrier shall be constructed around the entire construction site perimeter to prevent erosion from infiltrating the storm water drainage system.

PAYMENT

The Contractor may invoice the Owner for work performed on a monthly basis. The work performed shall meet the approval of UL Lafayette. UL Lafayette shall process payment after verification of the invoice.

On Projects where a performance bond is specified, the University will withhold ten percent (10%) retainage from all payments for completed work. The retainage will be released to the contractor according to the procedures set forth in the "INSTRUCTIONS TO BIDDERS AND GENERAL CONDITIONS", section 10.

FINAL PAYMENT WILL NOT BE ISSUED UNTIL ALL UNIVERSITY KEYS HAVE BEEN RETURNED TO THE FACILITY MANAGEMENT OFFICE.

CLEAN-UP

The Contractor is responsible for the daily clean-up and disposal of all trash and construction debris relating to this Project. University dumpsters shall not be used for the disposal of debris. Should the Contractor dispose of any debris into University facilities, the cost of removal will be deducted from the University's final payment under this contract. Occupied areas (e.g.: Classrooms, Offices, Labs, etc.) shall be broom cleaned and vacuumed at the end of the work day to allow use of the room by the University. Debris and materials shall be removed from the rooms to allow use of the room by the University.

INDEMNIFICATION

The Contractor will indemnify and hold harmless the Owner and all of their agents and employees from and against all claims, damages, losses, and expenses including attorney's fees arising out of or resulting from operations under the Contract Documents by the Contractor, and subcontractor, anyone directly or indirectly employed by any of them, or anyone for whose acts any of them may be liable, which are caused in whole or in part by any error, omission, or act of any of them. If any and all claims against the Owner or any of their agents or employees by any employee of the Contractor, subcontractor, anyone directly or indirectly employed by any of them, or anyone for whose acts any of them may be liable,

the indemnification obligation of the Contractor under this article shall not be limited in any way by any limitation on the amount or type of damages, compensation or benefits payable by or for the Contractor or any subcontractor under Workmen's Compensation laws.

SPECIAL HEALTH & SAFETY RELATED CONTRACT CLAUSES:

ADDITIONAL CONTRACTOR REQUIREMENTS AND LIMITATION OF LIABILITY

It is expressly understood and agreed by the parties that:

(a) CONTRACTOR shall not visit or utilize the facilities of university if CONTRACTOR (i) experiences symptoms of COVID-19, including, without limitation, fever, cough, or shortness of breath, or (ii) has a suspected or diagnosed/confirmed case of COVID-19, and CONTRACTOR shall notify University immediately if he or she believes that any of the foregoing access/use restrictions may apply;

(b) University has taken certain steps to implement recommended guidance and protocols issued by the Centers for Disease Control ("CDC") and Louisiana Department of Health ("LDH") for slowing the transmission of COVID-19, including, without limitation, the access/use restrictions, and distancing and sanitization requirements set forth herein, and that University may revise its procedures at any time based on updated recommended guidance and protocols issued by the CDC and LDH and CONTRACTOR agrees to comply with University's current and revised procedures prior to utilizing the facilities of University;

(c) CONTRACTOR acknowledges and agrees that, due to the nature of the facilities and the services CONTRACTOR is providing to University, social distancing of six (6) feet per person may not always be possible and CONTRACTOR fully understands and appreciates both the known and potential dangers of utilizing the facilities of University and acknowledges that use thereof by CONTRACTOR may, despite University's reasonable efforts to mitigate such dangers, result in exposure to COVID-19, which could result in quarantine requirements, serious illness, disability, and/or death; and

(d) while University has instituted measures to sanitize common areas, CONTRACTOR shall be responsible for the daily sanitization of his/her personal workspace prior to and immediately preceding CONTRACTOR's use of the space. Under no circumstances shall University be liable to CONTRACTOR, or CONTRACTOR's personal representatives, assigns, heirs, and next of kin for any loss or damage, or any claim or demands on account of any property damage or any injury to, or an illness or the death of, the CONTRACTOR (or any person who may contract COVID-19, directly or indirectly, from the CONTRACTOR) whether caused by the negligence, active or passive, of University or otherwise while CONTRACTOR is in, upon, of about the premises or ay facilities or equipment therein of University.

FORCE MAJEURE

Notwithstanding anything to the contrary in this Agreement, neither party shall be liable to the other or be deemed to be in breach of this Agreement for any failure or delay in whole or partial performance under this Agreement when such failure or delay is caused in whole or in part by a "Force Majeure Event," which shall be defined as any event beyond the control of a party, including, but not limited to: labor disputes, strike, riot, vandalism, sabotage, terrorist act, war (whether declared or undeclared), inclement weather, flood (whether naturally occurring or manmade), tidal surge or tsunami, landslide, earthquake, fire (whether naturally occurring or manmade), explosion, power shortage or outage, fuel shortage, embargo, congestion or service failure, epidemic, or government regulation, proclamation, order, or action; and in each case not involving the fault or negligence of a party.

If any Force Majeure Event occurs affecting a party's performance under this Agreement, the affected party will give written notice within five (5) days of the occurrence of the Force Majeure Event to the other party and will use commercially reasonable efforts to minimize the impact of the Force Majeure Event. In the event of a Force Majeure Event resulting in a total or partial performance or service failure by either party, the University, in its sole discretion, may immediately terminate this Agreement. To the extent that services have been rendered and deemed acceptable by university, the service fee and other fees and charges payable by University hereunder shall be paid to the Contractor on a pro-rata basis. For those services which the Contractor is unable to perform under this Agreement as a result of such Force Majeure Event, University shall suspend all related payments until such services are restored.

END OF SECTION

Guidelines for Electronic Submission of Bids and Virtual Bid Openings

In keeping with the physical distancing guidelines associated with COVID-19 Public Health Emergency declared by Governor John Bel Edwards in Proclamation Numbers 41, 33, 32, 30, 27, and 25 JBE 2020, the Purchasing Department at the University of Louisiana at Lafayette is suspending in-person attendance at public bid openings. All tasks associated with sealed bids and corresponding bid openings will be completed electronically to the greatest extent possible.

BID SUBMISSIONS - USPS Mail bid submittal and In-person delivery of bids at the Purchasing Office ARE NO LONGER ACCEPTED.

This information applies to competitive sealed bids. Bidders shall submit proposals by **EMAIL ONLY**:

Electronic submittal: Bidders must submit bids electronically containing the mandatory information detailed in the bid specifications to be considered for the bid award. Without exception, the bid must be received at ULLafayetteBids@louisiana.edu on or before the date and time specified as its deadline. Bidders e-mailing their bids should allow sufficient time to ensure receipt of their proposal by the time specified. The timestamp recorded in the email acknowledgement shall be the official time of the submission.

The electronic submittal must contain the following information in the Subject Line:

File Number Company Name

LA Contractor's License No. (if applicable)

If the file size of the email submission exceeds server requirements, the email submission may be broken into smaller email messages with "Part 1 of __" included at the end of each original Subject Line (e.g. File No. 22200 – ABC Contractors, License No. 12345, Part 1 of 3).

The University assumes no responsibility for assuring accurate/complete e-mail transmission and receipt. The responsibility lies solely with each bidder to ensure their submission is received at the specified email address prior to the deadline. Proposals received after the deadline, corrupted files, and incomplete submissions (e.g. Part 1 and Part 2 of 3 are received, but Part 3 is not) shall not be considered.

Bids advertised on LAPAC will show a solicitation file number formatted like 50011-ULLAF#####. It is only necessary to include the last five (5) digits of that number in the Subject Line.

Bids shall be submitted in .pdf format. Faxed submittals will not be accepted.

Bid Submissions for Public Works/Construction

In addition to the above, the following applies to Title 38 Public Works electronic bid submittals.

The bidder must sign electronically or submit a scanned signature on the Louisiana Uniform Public Works Bid Form.

As stated on the Louisiana Uniform Public Works Bid Form, a corporate resolution or written evidence of the authority of the person signing the bid for the public work as prescribed by LA R.S. 38:2212(B)(5) shall be enclosed, if your business is a corporation.

Bid submittal shall include security equal to 5% of bid. bid security shall be drawn in favor of the University of Louisiana at Lafayette and SHALL be in the form of a Bid Bond (Insurance Company), Bank Money Order*, Certified Check* or Cashier's Check*.

Bid security in the form of a Bank Money Order, Certified Check* or Cashier's Check* shall be accepted as bid security when submitting bids electronically if both the front and back of the bid security is scanned and included with the bid submission. The hard copy of that document must be received no later than three (3) business days after the bid opening at:

University of Louisiana at Lafayette Purchasing Office
PO Box 40197
Lafayette, LA 70504-0197

Louisiana Contractor's License Number shall be in the subject line of the bid for ALL bids greater than or equal to \$50,000.00. Bids for Plumbing/Electrical/Mechanical Work greater than or equal to \$10,000.00 shall disclose the Louisiana Contractor's License Number in the Subject Line.

Asbestos Abatement bids exceeding \$1.00 shall disclose the Louisiana Contractor's License Number in the Subject Line.

BID OPENINGS

Bid openings will continue to be open to the public, conducted virtually using Zoom. To ensure an accurate list of attendees, parties interested in viewing the opening must register for the meeting.

The link to register for each bid opening shall be provided with the Invitation to Bid. The link will be live at that time and will provide live audio access to the bid opening.

The Bid Opening Zoom meeting shall begin at the top of the hour listed in the specifications as the Bid Opening time. The actual opening of bids shall begin at five (5) past the hour to allow all attendees to log in and sign in properly. The public bid opening for this solicitation will take place on Tuesday, October 10, 2023 at 3:00PM on Zoom, which is available for viewing by registering at https://ullafayette.zoom.us/meeting/register/tJEqdemqpzkiGtEpbS1A5EtSRpuHn_yEjkFJ.

Meeting ID: [957 2029 2905](#) Password: [24204](#)

Requests for bid tabulations and solicitation inquiries should be directed to purchasing@louisiana.edu as listed in the solicitation/ITB.

END OF SECTION

VENDOR CHECK LIST

REQUIRED FORMS/ITEMS UPON BID SUBMISSION

- _____ Louisiana Uniform Public Works Bid Form
- _____ Bid Security Equal to 5% of Bid
- _____ Louisiana Contractor's License Number (If Applicable) in Subject Line of email
- _____ If company bidding is a corporation, Corporate Resolution or written evidence of authority of person signing the bid for the public work (See ***annotation on Louisiana Public Work Bid Form.*)

REQUIRED FORMS AFTER BID OPENING/UPON BID AWARD

- _____ Attestation Affidavit (ALL BIDDERS, WITHIN 10 DAYS OF BID OPENING)
- _____ Non-Collusion Affidavit (LOW BIDDER, WITHIN 10 DAYS OF REQUEST)
- _____ Disclosure of Ownership Affidavit (LOW BIDDER, WITHIN 10 DAYS OF REQUEST)
- _____ Performance and Payment Bond (LOW BIDDER, WITHIN 10 DAYS OF REQUEST)
- _____ Certificate of Insurance (*Insurance requirements revised February 2019*)
- _____ Certificate of Recordation of Contract and Bonds
- _____ Clear Lien Certificate

CONTACT INFORMATION

ELECTRONIC BID SUBMISSIONS (ONLY) *Do not email questions about the bid to this email address.*

ULLafayetteBids@louisiana.edu

Be sure to include the solicitation number in the subject line.

Do not send your submission to any other University email address.

QUESTIONS/CONCERNS ABOUT SPECIFICATIONS

purchasing@louisiana.edu mary.borel@louisiana.edu

Do not email bid submissions to either of these addresses.

To contact Purchasing by phone: 337.482.9051.

CAMPUS DELIVERIES

The campus is not fully open for receiving deliveries by courier at this time. Please send samples or other associated documents via US Mail only when a hard copy is requested or deemed necessary. The UL- Lafayette Post Office (located inside the Student Union) will accept packages with proper postage to place in the Purchasing Department's mailbox. The phone number is 337.482.6113.

LOUISIANA UNIFORM PUBLIC WORK BID FORM

TO: University of Louisiana at Lafayette
 Purchasing Office, Martin Hall Room 123
 104 University Circle
 PO Box 40197
 Lafayette, LA 70504

BID FOR: **NIRC BUILDING 10B ELECTRICAL MODIFICATIONS (REBID)**
 LOCATION: NEW IBERIA RESEARCH CENTER
 File No.: 24204

The undersigned bidder hereby declares and represents that she/he: a) has carefully examined and understands the Bidding Documents, b) has not received, relied on, or based his bid on any verbal instructions contrary to the Bidding Documents or any addenda, c) has personally inspected and is familiar with the Project site, and hereby proposes to provide all labor, materials, tools, appliances and facilities as required to perform, in a workmanlike manner, all work and services for the construction and completion of the referenced Project, all in strict accordance with the Bidding Documents prepared by:

University of Louisiana at Lafayette and dated: August 2023
 (Owner to provide name of entity preparing bidding documents.)

Bidder must acknowledge all addenda. The Bidder acknowledges receipt of the following ADDENDA: (Enter the number the Designer has assigned to each of the addenda that the Bidder is acknowledging) _____

TOTAL BASE BID: For all work required by the Bidding Documents (including any and all unit prices designated "Base Bid"* but not alternates) the sum of:

_____ Dollars (\$ _____)

ALTERNATES: For any and all work required by the Bidding Documents for Alternates including any and all unit prices designated as alternates in the unit price description.

Alternate No. 1: : (Owner to provide description of alternate and state whether add or deduct) for the lump sum of:

_____ Dollars (\$ _____)

Alternate No. 2: : (Owner to provide description of alternate and state whether add or deduct) for the lump sum of:

_____ Dollars (\$ _____)

Alternate No. 3: : (Owner to provide description of alternate and state whether add or deduct) for the lump sum of:

_____ Dollars (\$ _____)

NAME OF BIDDER: _____

ADDRESS OF BIDDER: _____

LOUISIANA CONTRACTOR'S LICENSE NUMBER: _____

NAME OF AUTHORIZED SIGNATORY OF BIDDER: _____

TITLE OF AUTHORIZED SIGNATORY OF BIDDER: _____

SIGNATURE OF AUTHORIZED SIGNATORY OF BIDDER** : _____

DATE: _____

* The Unit Price Form shall be used if the contract includes unit prices. Otherwise, it is not required and need not be included with the form. The number of unit prices that may be included is not limited and additional sheets may be included if needed.

** A CORPORATE RESOLUTION OR WRITTEN EVIDENCE of the authority of the person signing the bid for the public work as prescribed by LA R.S. 38:2212(B)(5). BID SECURITY in the form of a bid bond, certified check or cashier's check as prescribed by LA RS 38:2218(A) attached to and made a part of this bid.

ATTESTATIONS AFFIDAVIT – PAGE 1 OF 2

NIRC BUILDING 10B ELECTRICAL MODIFICATIONS (REBID)**24204**

Name of Project

Project No.

STATE OF LOUISIANAPARISH OF IBERIA**ATTESTATIONS AFFIDAVIT**

Before me, the undersigned notary public, duly commissioned and qualified in and for the parish and state aforesaid, personally came and appeared Affiant, who after being duly sworn, attested as follows:

LA. R.S. 38:2227 PAST CRIMINAL CONVICTIONS OF BIDDERS

- A. No sole proprietor or individual partner, incorporator, director, manager, officer, organizer, or member who has a minimum of a ten percent (10%) ownership in the bidding entity named below has been convicted of, or has entered a plea of guilty or nolo contendere to any of the following state crimes or equivalent federal crimes:

- | | |
|---------------------------------------|-----------------------------------|
| (a) Public bribery (R.S. 14:118) | (c) Extortion (R.S. 14:66) |
| (b) Corrupt influencing (R.S. 14:120) | (d) Money laundering (R.S. 14:23) |

- B. Within the past five years from the Project bid date, no sole proprietor or individual partner, incorporator, director, manager, officer, organizer, or member who has a minimum of a ten percent (10%) ownership in the bidding entity named below has been convicted of, or has entered a plea of guilty or nolo contendere to any of the following state crimes or equivalent federal crimes, during the solicitation or execution of a contract or bid awarded pursuant to the provisions of Chapter 10 of Title 38 of the Louisiana Revised Statutes:

- | | |
|--------------------------------------------------|--------------------------------------------------------------|
| (a) Theft (R.S. 14:67) | (f) Bank fraud (R.S. 14:71.1) |
| (b) Identity Theft (R.S. 14:67.16) | (g) Forgery (R.S. 14:72) |
| (c) Theft of a business record
(R.S.14:67.20) | (h) Contractors; misapplication of
payments (R.S. 14:202) |
| (d) False accounting (R.S. 14:70) | (i) Malfeasance in office (R.S. 14:134) |
| (e) Issuing worthless checks
(R.S. 14:71) | |

LA.R.S.38:2212.10 Verification of Employees

A. At the time of bidding, Appearer is registered and participates in a status verification system to verify that all new hires in the state of Louisiana are legal citizens of the United States or are legal aliens.

B. If awarded the contract, Appearer shall continue, during the term of the contract, to utilize a status verification system to verify the legal status of all new employees in the state of Louisiana.

C. If awarded the contract, Appearer shall require all subcontractors to submit to it a sworn affidavit verifying compliance with Paragraphs (A) and (B) of this Subsection.

ATTESTATIONS AFFIDAVIT – PAGE 2 OF 2

NIRC BUILDING 10B ELECTRICAL MODIFICATIONS (REBID)

24204

Name of Project

Project No.

LA. R.S. 23:1726(B) Certification Regarding Unpaid Workers Compensation Insurance

A.R.S. 23:1726 prohibits any entity against whom an assessment under Part X of Chapter 11 of Title 23 of the Louisiana Revised Statutes of 1950 (Alternative Collection Procedures & Assessments) is in effect, and whose right to appeal that assessment is exhausted, from submitting a bid or proposal for or obtaining any contract pursuant to Chapter 10 of Title 38 of the Louisiana Revised Statutes of 1950 and Chapters 16 and 17 of Title 39 of the Louisiana Revised Statutes of 1950.

B. By signing this bid /proposal, Affiant certifies that no such assessment is in effect against the bidding / proposing entity.

NAME OF BIDDER

NAME OF AUTHORIZED SIGNATORY OF BIDDER

DATE

TITLE OF AUTHORIZED SIGNATORY OF BIDDER

SIGNATURE OF AUTHORIZED
SIGNATORY OF BIDDER/AFFIANT

Sworn to and subscribed before me by Affiant on the ____ day of _____, 20 ____.

Notary Public

NON-COLLUSION AFFIDAVIT

PAGE 1 OF 1 STATE OF LOUISIANA

[X] PARISH OF IBERIA [] COUNTY OF _____

AFFIDAVIT ATTESTING THAT PUBLIC CONTRACT WAS NOT NOR WILL BE SECURED

THROUGH EMPLOYMENT OR PAYMENT OF SOLICITOR

KNOW ALL MEN BY THESE PRESENCE, that a public contract is contemplated between

University of Louisiana at Lafayette and _____

represented by (print or type) _____ att

ests that s/he is empowered and authorized to execute said documents.

FURTHER, (signature) _____, who being duly sworn, does depose and attest that:

- 1) Affiant employed no person, corporation, firm, association, or other organization, either directly or indirectly, to secure the public contract under which he received payment, other than persons regularly employed by the affiant whose services in connection with the construction, alteration or demolition of the public building or Project or in securing the public contract wherein the regular course of their duties for affiant; and
2) That no part of the contract price received by affiant was paid or will be paid to any person, Corporation, firm, association, or other organization for soliciting the contract, other than the payment of their normal compensation to persons regularly employed by the affiant whose services in connection with the construction, alteration or demolition of the public building or Project were in the regular course of their duties for affiant.

BEFORE ME, the representing authority, personally appeared, who being duly sworn, deposes and states that the above is true and correct in all respects recited.

SWORN TO AND SUBSCRIBED before me, this _____ day of _____, 20_____.

Notary Public

**ATTACHMENT A
TO FOLLOW IMMEDIATELY**

April, 2023

New Iberia Research Center
Building 10B – Electrical Modifications

SECTION 260500 - BASIC ELECTRICAL MATERIALS AND METHODS

PART 1 - GENERAL

1.1 RELATED DOCUMENTS

- A. Drawings and general provisions of the Contract, including General and Supplementary Conditions and Division 1 Specification Sections, apply to this Section.

1.2 SUMMARY

- A. This Section includes the following:
1. Raceways.
 2. Building wire and connectors.
 3. Supporting devices for electrical components.
 4. Electrical identification.
 5. Electricity-metering components.
 6. Concrete equipment bases.
 7. Electrical demolition.
 8. Cutting and patching for electrical construction.
 9. Touchup painting.

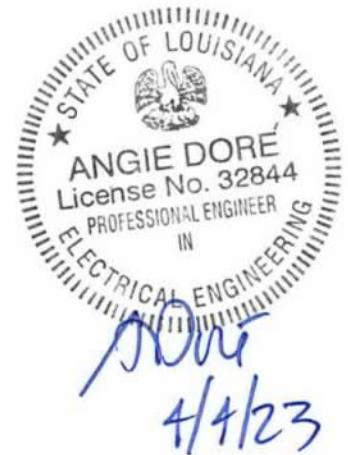

1.3 DEFINITIONS

- A. EMT: Electrical metallic tubing.
- B. FMC: Flexible metal conduit.
- C. IMC: Intermediate metal conduit.
- D. LFMC: Liquidtight flexible metal conduit.
- E. RNC: Rigid nonmetallic conduit.

1.4 QUALITY ASSURANCE

- A. Electrical Components, Devices, and Accessories: Listed and labeled as defined in NFPA 70, Article 100, by a testing agency acceptable to authorities having jurisdiction, and marked for intended use.
- B. Comply with NFPA 70, most recent addition.

1.5 COORDINATION

- A. Coordinate chases, slots, inserts, sleeves, and openings with general construction work and arrange in building structure during progress of construction to facilitate the electrical installations that follow.
 - 1. Set inserts and sleeves in poured-in-place concrete, masonry work, and other structural components as they are constructed.
- B. Sequence, coordinate, and integrate installing electrical materials and equipment for efficient flow of the Work. Coordinate installing large equipment requiring positioning before closing in the building.
- C. Coordinate electrical service connections to components furnished by utility companies.
 - 1. Coordinate installation and connection of exterior underground and overhead utilities and services, including provision for electricity-metering components.
 - 2. Comply with requirements of authorities having jurisdiction and of utility company providing electrical power and other services.
- D. Coordinate location of access panels and doors for electrical items that are concealed by finished surfaces. Access doors and panels are specified in Division 8 Section "Access Doors."
- E. Where electrical identification devices are applied to field-finished surfaces, coordinate installation of identification devices with completion of finished surface.
- F. Where electrical identification markings and devices will be concealed by acoustical ceilings and similar finishes, coordinate installation of these items before ceiling installation.

PART 2 - PRODUCTS

2.1 RACEWAYS

- A. EMT: ANSI C80.3, zinc-coated steel, with compression fittings.
- B. FMC: Zinc-coated steel.
- C. IMC: ANSI C80.6, zinc-coated steel, with threaded fittings.
- D. LFMC: Zinc-coated steel with sunlight-resistant and mineral-oil-resistant plastic jacket.
- E. RNC: NEMA TC 2, Schedule 40 PVC, with NEMA TC3 fittings.
- F. Raceway Fittings: Specifically designed for the raceway type with which used.

2.2 CONDUCTORS

- A. Conductors, No. 10 AWG and Smaller: Solid copper.
- B. Conductors, Larger Than No. 10 AWG: Stranded copper.

- C. Insulation: Thermoplastic, rated at 75 deg C minimum.
- D. Wire Connectors and Splices: Units of size, ampacity rating, material, type, and class suitable for service indicated.

2.3 SUPPORTING DEVICES

- A. Material: Cold-formed steel, with corrosion-resistant coating acceptable to authorities having jurisdiction.
- B. Metal Items for Use Outdoors or in Damp Locations: Hot-dip galvanized steel.
- C. Slotted-Steel Channel Supports: Flange edges turned toward web, and 9/16-inch- diameter slotted holes at a maximum of 2 inches o.c., in webs.
- D. Slotted-Steel Channel Supports: Comply with Division 5 Section "Metal Fabrications" for slotted channel framing.
 - 1. Channel Thickness: Selected to suit structural loading.
 - 2. Fittings and Accessories: Products of the same manufacturer as channel supports.
- E. Nonmetallic Channel and Angle Systems: Structural-grade, factory-formed, glass-fiber-resin channels and angles with 9/16-inch- diameter holes at a maximum of 8 inches o.c., in at least one surface.
 - 1. Fittings and Accessories: Products of the same manufacturer as channels and angles.
 - 2. Fittings and Accessory Materials: Same as channels and angles, except metal items may be stainless steel.
- F. Raceway and Cable Supports: Manufactured clevis hangers, riser clamps, straps, threaded C-clamps with retainers, ceiling trapeze hangers, wall brackets, and spring-steel clamps or click-type hangers.
- G. Pipe Sleeves: ASTM A 53, Type E, Grade A, Schedule 40, galvanized steel, plain ends.
- H. Cable Supports for Vertical Conduit: Factory-fabricated assembly consisting of threaded body and insulating wedging plug for nonarmored electrical cables in riser conduits. Plugs have number and size of conductor gripping holes as required to suit individual risers. Body constructed of malleable-iron casting with hot-dip galvanized finish.
- I. Expansion Anchors: Carbon-steel wedge or sleeve type.
- J. Toggle Bolts: All-steel springhead type.
- K. Powder-Driven Threaded Studs: Heat-treated steel.

2.4 ELECTRICAL IDENTIFICATION

- A. Identification Devices: A single type of identification product for each application category. Use colors prescribed by ANSI A13.1, NFPA 70, and these Specifications.
- B. Raceway and Cable Labels: Comply with ANSI A13.1, Table 3, for minimum size of letters for legend and minimum length of color field for each raceway and cable size.
 - 1. Type: Pretensioned, wraparound plastic sleeves. Flexible, preprinted, color-coded, acrylic band sized to suit the diameter of the item it identifies.
 - 2. Type: Preprinted, flexible, self-adhesive, vinyl. Legend is overlaminated with a clear, weather- and chemical-resistant coating.
 - 3. Color: Black letters on orange background.
 - 4. Legend: Indicates voltage.
- C. Colored Adhesive Marking Tape for Raceways, Wires, and Cables: Self-adhesive vinyl tape, not less than 1 inch wide by 3 mils thick.
- D. Underground Warning Tape: Permanent, bright-colored, continuous-printed, vinyl tape with the following features:
 - 1. Not less than 6 inches wide by 4 mils thick.
 - 2. Compounded for permanent direct-burial service.
 - 3. Embedded continuous metallic strip or core.
 - 4. Printed legend that indicates type of underground line.
- E. Tape Markers for Wire: Vinyl or vinyl-cloth, self-adhesive, wraparound type with preprinted numbers and letters.
- F. Color-Coding Cable Ties: Type 6/6 nylon, self-locking type. Colors to suit coding scheme.
- G. Engraved-Plastic Labels, Signs, and Instruction Plates: Engraving stock, melamine plastic laminate punched or drilled for mechanical fasteners 1/16-inch minimum thickness for signs up to 20 sq. in. and 1/8-inch minimum thickness for larger sizes. Engraved legend in black letters on white background.
- H. Interior Warning and Caution Signs: Comply with 29 CFR, Chapter XVII, Part 1910.145. Preprinted, aluminum, baked-enamel-finish signs, punched or drilled for mechanical fasteners, with colors, legend, and size appropriate to the application.
- I. Exterior Warning and Caution Signs: Comply with 29 CFR, Chapter XVII, Part 1910.145. Weather-resistant, nonfading, preprinted, cellulose-acetate butyrate signs with 0.0396-inch, galvanized-steel backing, with colors, legend, and size appropriate to the application. 1/4-inch grommets in corners for mounting.
- J. Fasteners for Nameplates and Signs: Self-tapping, stainless-steel screws or No. 10/32 stainless-steel machine screws with nuts and flat and lock washers.

2.5 CONCRETE BASES

- A. Concrete Forms and Reinforcement Materials: As specified in Division 3 Section "Cast-in-Place Concrete."

- B. Concrete: 4000-psi, 28-day compressive strength as specified in Division 3 Section "Cast-in-Place Concrete."

2.6 TOUCHUP PAINT

- A. For Equipment: Equipment manufacturer's paint selected to match installed equipment finish.
- B. Galvanized Surfaces: Zinc-rich paint recommended by item manufacturer.

PART 3 – EXECUTION

3.1 ELECTRICAL EQUIPMENT INSTALLATION

- A. Headroom Maintenance: If mounting heights or other location criteria are not indicated, arrange and install components and equipment to provide the maximum possible headroom.
- B. Materials and Components: Install level, plumb, and parallel and perpendicular to other building systems and components, unless otherwise indicated.
- C. Equipment: Install to facilitate service, maintenance, and repair or replacement of components. Connect for ease of disconnecting, with minimum interference with other installations.
- D. Right of Way: Give to raceways and piping systems installed at a required slope.

3.2 RACEWAY APPLICATION

- A. Use the following raceways for outdoor installations:
 - 1. Exposed: IMC or Rigid Steel.
 - 2. Concealed: IMC or Rigid Steel.
 - 3. Underground, Single Run: RNC.
 - 4. Underground, Grouped: RNC.
 - 5. Connection to Vibrating Equipment: LFMC.
 - 6. Boxes and Enclosures: NEMA 250, Type 3R or Type 4.
- B. Use the following raceways for indoor installations:
 - 1. Exposed: EMT.
 - 2. Concealed: EMT.
 - 3. Connection to Vibrating Equipment: FMC; except in wet or damp locations, use LFMC.
 - 4. Damp or Wet Locations: IMC.
 - 5. Boxes and Enclosures: NEMA 250, Type 1, unless otherwise indicated.

3.3 RACEWAY AND CABLE INSTALLATION

- A. Conceal raceways and cables, unless otherwise indicated, within finished walls, ceilings, and floors.

- B. Install raceways and cables at least 6 inches away from parallel runs of flues and steam or hot-water pipes. Locate horizontal raceway runs above water and steam piping.
 - C. Use temporary raceway caps to prevent foreign matter from entering.
 - D. Make conduit bends and offsets so ID is not reduced. Keep legs of bends in the same plane and straight legs of offsets parallel, unless otherwise indicated.
 - E. Use raceway and cable fittings compatible with raceways and cables and suitable for use and location.
 - F. Install raceways below slab foundations and leave at least 6-inch bury depth below vapor barrier. Compact as per specifications in 6" layers using power tamping equipment.
 - 1. Secure raceways to reinforcing rods to prevent sagging or shifting during concrete placement.
 - 2. Space raceways laterally to prevent voids in concrete.
 - 3. Transition from nonmetallic tubing to Schedule 80 nonmetallic conduit, rigid steel conduit, or IMC before rising above floor.
 - 4. Make bends in exposed parallel or banked runs from same centerline to make bends parallel. Use factory elbows only where elbows can be installed parallel; otherwise, provide field bends for exposed parallel raceways.
 - G. Install pull wires in empty raceways. Use No. 14 AWG zinc-coated steel or monofilament plastic line with not less than 200-lb tensile strength. Leave at least 12 inches of slack at each end of the pull wire.
 - H. Install telephone and signal system raceways, 2-inch trade size and smaller, in maximum lengths of 150 feet and with a maximum of two 90-degree bends or equivalent. Separate lengths with pull or junction boxes where necessary to comply with these requirements, in addition to requirements above.
 - I. Connect motors and equipment subject to vibration, noise transmission, or movement with a maximum of 72-inch flexible conduit. Install LFMC in wet or damp locations. Install separate ground conductor across flexible connections.
 - J. Set floor boxes level and trim after installation to fit flush to finished floor surface.
- 3.4 WIRING METHODS FOR POWER, LIGHTING, AND CONTROL CIRCUITS
- A. Feeders: Type THHN/THWN insulated conductors in raceway.
 - B. Underground Feeders and Branch Circuits: Type THWN
 - C. Branch Circuits: Type THHN/THWN insulated conductors in raceway. ¾" minimum conduit when raceways below grade
 - D. Remote-Control Signaling and Power-Limited Circuits: Type THHN/THWN insulated conductors in raceway for Classes 1, 2, and 3, unless otherwise indicated.

3.5 WIRING INSTALLATION

- A. Install splices and taps that are compatible with conductor material and that possess equivalent or better mechanical strength and insulation ratings than unspliced conductors.
- B. Install wiring at outlets with at least 8 inches of slack conductor at each outlet.
- C. Connect outlet and component connections to wiring systems and to ground. Tighten electrical connectors and terminals, according to manufacturer's published torque-tightening values. If manufacturer's torque values are not indicated, use those specified in UL 486A.

3.6 ELECTRICAL SUPPORTING DEVICE APPLICATION

- A. Damp Locations and Outdoors: Hot-dip galvanized materials or nonmetallic, U-channel system components.
- B. Dry Locations: Steel materials.
- C. Selection of Supports: Comply with manufacturer's written instructions.
- D. Strength of Supports: Adequate to carry present and future loads, times a safety factor of at least four; minimum of 200-lb design load.

3.7 SUPPORT INSTALLATION

- A. Install support devices to securely and permanently fasten and support electrical components. Support solely from structural steel framing members.
- B. Install individual and multiple raceway hangers and riser clamps to support raceways. Provide U-bolts, clamps, attachments, and other hardware necessary for hanger assemblies and for securing hanger rods and conduits.
- C. Support parallel runs of horizontal raceways together on trapeze- or bracket-type hangers.
- D. Size supports for multiple raceway installations so capacity can be increased by a 25 percent minimum in the future.
- E. Support individual horizontal raceways with separate, malleable-iron pipe hangers or clamps.
- F. Install 1/4-inch- diameter or larger threaded steel hanger rods, unless otherwise indicated.
- G. Spring-steel fasteners specifically designed for supporting single conduits or tubing may be used instead of malleable-iron hangers for 1-1/2-inch and smaller raceways serving lighting and receptacle branch circuits above suspended ceilings and for fastening raceways to slotted channel and angle supports.

- H. Arrange supports in vertical runs so the weight of raceways and enclosed conductors is carried entirely by raceway supports, with no weight load on raceway terminals.
- I. Simultaneously install vertical conductor supports with conductors.
- J. Separately support cast boxes that are threaded to raceways and used for fixture support. Support sheet-metal boxes directly from the building structure or by bar hangers. If bar hangers are used, attach bar to raceways on opposite sides of the box and support the raceway with an approved fastener not more than 24 inches from the box.
- K. Install metal channel racks for mounting cabinets, panelboards, disconnect switches, control enclosures, pull and junction boxes, transformers, and other devices unless components are mounted directly to structural elements of adequate strength.
- L. Install sleeves for cable and raceway penetrations of concrete slabs and walls unless core-drilled holes are used. Install sleeves for cable and raceway penetrations of masonry and fire-rated gypsum walls and of all other fire-rated floor and wall assemblies. Install sleeves during erection of concrete and masonry walls.
- M. Securely fasten electrical items and their supports to the building structure, unless otherwise indicated. Perform fastening according to the following unless other fastening methods are indicated:
 - 1. Wood: Fasten with wood screws or screw-type nails.
 - 2. Masonry: Toggle bolts on hollow masonry units and expansion bolts on solid masonry units.
 - 3. New Concrete: Concrete inserts with machine screws and bolts.
 - 4. Existing Concrete: Expansion bolts.
 - 5. Instead of expansion bolts, threaded studs driven by a powder charge and provided with lock washers may be used in existing concrete.
 - 6. Steel: Welded threaded studs or spring-tension clamps on steel.
 - a. Field Welding: Comply with AWS D1.1.
 - 7. Welding to steel structure may be used only for threaded studs, not for conduits, pipe straps, or other items.
 - 8. Light Steel: Sheet-metal screws.
 - 9. Fasteners: Select so the load applied to each fastener does not exceed 25 percent of its proof-test load.

3.8 IDENTIFICATION MATERIALS AND DEVICES

- A. Install at locations for most convenient viewing without interference with operation and maintenance of equipment.
- B. Coordinate names, abbreviations, colors, and other designations used for electrical identification with corresponding designations indicated in the Contract Documents or required by codes and standards. Use consistent designations throughout Project.
- C. Self-Adhesive Identification Products: Clean surfaces before applying.
- D. Identify raceways and cables with color banding as follows:

1. Bands: Pretensioned, snap-around, colored plastic sleeves or colored adhesive marking tape. Make each color band 2 inches wide, completely encircling conduit, and place adjacent bands of two-color markings in contact, side by side.
 2. Band Locations: At changes in direction, at penetrations of walls and floors, at 50-foot maximum intervals in straight runs, and at 25-foot maximum intervals in congested areas.
- E. Tag and label circuits designated to be extended in the future. Identify source and circuit numbers in each cabinet, pull and junction box, and outlet box. Color-coding may be used for voltage and phase identification.
- F. Install continuous underground plastic markers during trench backfilling, for exterior underground power, control, signal, and communication lines located directly above power and communication lines. Locate 6 to 8 inches below finished grade. If width of multiple lines installed in a common trench or concrete envelope does not exceed 16 inches, overall, use a single line marker.
- G. Color-code 208/120-V system secondary service, feeder, and branch-circuit conductors throughout the secondary electrical system as follows:
1. Phase A: Black.
 2. Phase B: Red.
 3. Phase C: Blue.
 4. Neutral: White.
- H. Install warning, caution, and instruction signs where required to comply with 29 CFR, Chapter XVII, Part 1910.145, and where needed to ensure safe operation and maintenance of electrical systems and of items to which they connect. Install engraved plastic-laminated instruction signs with approved legend where instructions are needed for system or equipment operation. Install metal-backed butyrate signs for outdoor items.
- I. Install engraved-laminated emergency-operating signs with white letters on red background with minimum 3/8-inch- high lettering for emergency instructions on power transfer, load shedding, and other emergency operations.

3.9 FIRESTOPPING

- A. Apply firestopping to cable and raceway penetrations of fire-rated floor and wall assemblies to achieve fire-resistance rating of the assembly. Firestopping materials and installation requirements are specified in Division 7 Section "Firestopping."

3.10 CUTTING AND PATCHING

- A. Cut, channel, chase, and drill floors, walls, partitions, ceilings, and other surfaces required to permit electrical installations. Perform cutting by skilled mechanics of trades involved.
- B. Repair and refinish disturbed finish materials and other surfaces to match adjacent undisturbed surfaces. Install new fireproofing where existing firestopping has been disturbed. Repair and refinish materials and other surfaces by skilled mechanics of trades involved.

3.11 FIELD QUALITY CONTROL

- A. Inspect installed components for damage and faulty work, including the following:
 - 1. Raceways.
 - 2. Building wire and connectors.
 - 3. Supporting devices for electrical components.
 - 4. Electrical identification.
 - 5. Electricity-metering components.
 - 6. Concrete bases.
 - 7. Electrical demolition.
 - 8. Cutting and patching for electrical construction.
 - 9. Touchup painting.

3.12 REFINISHING AND TOUCHUP PAINTING

- A. Refinish and touch up paint. Paint materials and application requirements are specified in Division 9 Section "Painting."
 - 1. Clean damaged and disturbed areas and apply primer, intermediate, and finish coats to suit the degree of damage at each location.
 - 2. Follow paint manufacturer's written instructions for surface preparation and for timing and application of successive coats.
 - 3. Repair damage to galvanized finishes with zinc-rich paint recommended by manufacturer.
 - 4. Repair damage to paint finishes with matching touchup coating recommended by manufacturer.

3.13 CLEANING AND PROTECTION

- A. On completion of installation, including outlets, fittings, and devices, inspect exposed finish. Remove burrs, dirt, paint spots, and construction debris.
- B. Protect equipment and installations and maintain conditions to ensure that coatings, finishes, and cabinets are without damage or deterioration at time of Substantial Completion.

END OF SECTION 260500

SECTION 260100 - ELECTRICAL GENERAL CONDITIONS

PART 1 - GENERAL

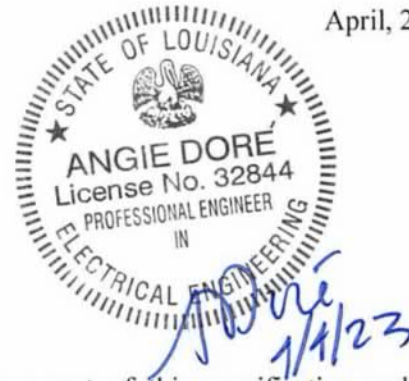

1.1 DESCRIPTION

- A. The General Conditions and all pertinent sections are a part of this specification and the Contractor shall consult them in detail for instructions pertaining to his work. He shall consult all other sections of the specifications to determine if he is required to perform any work relative to that particular section.

1.2 SCOPE OF WORK

- A. The work contemplated under this specification comprises the furnishing of all labor and materials required and necessary for the complete installation of electrical wiring in conduit for lighting control and power from the various panelboards to each ultimate outlet hereinafter specified and/or shown on the accompanying drawings. Said work shall be done in accordance with the latest edition of the National Electrical Code, NFPA codes and all local codes and ordinances. The specifications are intended to describe a complete workable system and bidders shall report any discrepancies or omissions preventing such workability prior to the time their bids are submitted.
- B. The work covered by this specification shall be as shown on the plans and called for herein, and shall be comprised generally of the following:
 - 1. Furnish and install all conduit and wiring raceways, conductors, disconnects, panels, etc.
 - 2. Furnish and install feeders and branch circuits.
 - 3. Furnish and install service to all mechanical devices.
 - 4. Furnish and install light fixtures.
- C. All equipment installed by this contractor shall be installed in strict accordance with instructions of the manufacturer.
- D. He shall install his work to meet existing conditions as found at the building site.
- E. The Electrical contractor is referred to the Architectural and Structural details for information in regards to the Architectural details. His work shall be done in strict accordance with local and state ordinances governing this class of work.

1.3 REJECTED WORK AND MATERIALS

- A. Should contractor introduce any materials different from those called for and described in specifications or shown on plans, it must on notification from the engineers, be immediately removed from building or premises.

1.4 SHOP DRAWINGS

- A. Before proceeding with work and/or within thirty (30) days award of the General Contract for this work, the Electrical Contractor shall furnish to the Architect/Engineer, complete shop and working drawings of such apparatus, equipment, controls, insulation, etc. to be provided in this project. These drawings shall give dimensions, weights, mounting data, performance curves, and other pertinent information. Shop drawings to be submitted as listed below.
 - 1. Panels/Panelboards/Switchboards.
 - 2. Disconnects.
 - 3. Lighting Fixtures.
 - 4. Conduit & Fittings.
 - 5. Electrical devices.
 - 6. Automatic Transfer Switch.
- B. The contractor may be required to submit shop drawings on any other material he supplies in construction of this project. These drawings shall be submitted at time requested by Architect/Engineer.

1.5 ADDITIONS AND CHANGES

- A. The accompanying drawings show approximate location of feeders, branch circuits, light and power circuits, etc. Complete and accurate details in regard to location of outlets, apparatus, etc. from location shown shall be made before roughing-in and without additional cost to the owner.

1.6 STANDARDS OF MATERIALS AND WORKMANSHIP

- A. All materials shall be new and listed by UL as conforming to its standards. Work shall be executed in a workmanlike manner and present a neat finished appearance when completed.

1.7 PRIOR APPROVAL AND DRAWINGS

- A. Whenever manufacturers or trade names are mentioned in these plans or specifications, the words "or approved equivalent" shall be assumed to follow whether or not so stated. Manufacturers or trade names are used to establish a standard of quality only and should not in any way be construed to infer a preference. Equivalent products which meet the Engineer's approval will be accepted, however these products must be submitted to the Engineer a minimum of ten (10) days prior to bid date. Submission shall include manufacturer's name, model number, rating table and construction features. Upon receipt and checking of this submittal, the Architect will issue an addendum listing items which are approved as equivalent to those specified. The Contractor shall base his bid solely on the items specified or included in the "Prior Approval Addendum" as no other items will be acceptable. Prior approval of a particular piece of equipment does not mean automatic final acceptance and will not relieve the Contractor of the responsibility of assuring himself that this equipment is in complete accord

with plans and specifications and will fit into the space provided. Submit shop drawings on all items of equipment for approval as hereinafter specified. The Engineer's approval of shop drawings shall not relieve the Contractor from the responsibility of incorrectly figured dimensions or any other errors that may be contained in these drawings. The omissions from the shop drawings, or specifications, even though approved by the Engineer, shall not relieve this Contractor from furnishing and erecting same. **Prior Approvals submitted electronically will be accepted but the burden of delivery confirmation is by Contractor.**

1.8 GUARANTEE

- A. The Contractor for this work shall be required to keep the work installed by him in repair and perfect working order for one year from date of completion and final acceptance; said guarantee shall be based on defective materials and substandard workmanship. Contractor shall furnish, free of cost to owner, all materials and labor necessary to comply with this guarantee.

1.9 LAWS, PERMITS AND INSPECTIONS

- A. This contractor shall at his own cost obtain all necessary permits, pay all legal fees and charges, and comply with all building and safety laws, ordinances and regulations relating to the building and the public health and safety, including NEC, NFPA, IBC and OSHA.
- B. Pay any and all fees required by local electric utility company to obtain electrical services outlined.

1.10 TESTS

- A. After installation is complete and at such time as the Engineers may direct, Contractor shall conduct an operating test for approval. Equipment shall be demonstrated to operate in accordance with requirements of this specification. The test shall be performed in the presence of Engineers. Contractor shall furnish all instruments and personnel required for the test.

1.11 CUTTING AND PATCHING

- A. Contractor shall do all cutting and patching where necessary at his own expense with approval of the Engineers as to cutting of any structural beams or joists, but all patching shall be done by crafts whose work is involved. After initial surfacing has been done, all further cutting, patching, and painting shall be done at this contractor's expense.

1.12 SAFETY PRECAUTIONS

- A. Contractor shall furnish and place proper guards for prevention of accidents. He shall provide and maintain any other necessary construction required to secure safety of life or property, including maintenance of sufficient lights during all night hours to secure such protection.
- B. Temporary electrical services shall be provided by electrical contractor during construction and

shall be maintained in perfect condition. Frayed, loose or opened connections shall not be used for temporary services. The Electrical Contractor shall use only equipment in first class working conditions for construction services. Contractor shall not use electrical services at existing school for construction.

1.13 SUPERVISION

- A. Contractor shall personally, or through an authorized and competent representative, constantly supervise the work done from beginning to completion and final acceptance. To the best of his ability he shall keep the same foreman and workmen throughout the project duration. During the progress of the work, it shall be subject to inspection by the representatives of the Engineers, and at these times, the contractor shall furnish the required information.

1.14 INSERTS AND OPENINGS

- A. Contractor shall furnish and install all inserts and hangers required to support conduit, cables, wireways, disconnect switches, etc.

1.15 OPENINGS THROUGH WALLS AND FLOORS

- A. Provide all slots, sleeved holes and other openings necessary through walls and floors, and through any other parts of the structure. Where conduits pass through walls which are intended as rated fire walls, leave-outs, penetrations or sleeves shall be sealed so as not to interfere with the rating of the wall.

1.16 BACKFILLING

- A. Contractor shall be responsible to backfill any trenches for electrical runs under the building, paving, or any area of the site by backfilling the bottom of the trench-up to the top of the conduit with sand, then placing compacted fill in 6" layers using power tamping equipment.

1.17 RECORD DRAWINGS

- A. The Contractor shall be provided with a set of prints of the original bidding documents by the Architect. The Contractor shall then have a set of sepia (reproducible plans) made.
- B. If the Contractor elects to vary from the contract documents and secures prior approval from the architect for any phase of the work, he shall record in a neat and readable manner, ALL such variances on the print in red. These changes shall then be transferred to the permanent set (sepia) at the completion of the job. Both the sepia and the original print shall be returned to the Engineer for documentation.
- C. All deviations from sizes, locations and from all other features of the installations shown in the Contract Documents shall be recorded.
- D. In addition, it shall be possible using these drawings to correctly and easily locate, identify and

establish sizes of all piping, directions, and the like, as well as other features of work which will be concealed underground and/or in the finished building. Locations of underground work shall be established by dimensions to columns, lines or walls, locating all turns, etc. and by properly referenced centerline.

- E. For work concealed in the building, sufficient information shall be given so it can be located with reasonable accuracy and ease. In some cases this may be by dimension. In others, it may be sufficient to illustrate the work on the drawings in relation to the spaces in the building near which it was actually installed. Architect's/Engineer's decision in this matter will be final.
- F. The following requirements apply to all "record" drawings:
 - 1. They shall be maintained at the contractor's expense.
 - 2. All such drawings shall be done carefully and neatly and in a form approved by the Engineer.
 - 3. Additional drawings shall be provided as necessary for clarification.
 - 4. They shall be kept up-to-date during the entire course of the work and shall be available upon request for examination by Engineer and when necessary, to establish clearances for other parts of the work.
 - 5. "Record" drawings shall be returned to the Architect upon completion of the work and are subject to approval of the Engineer.
 - 6. The Contractor shall refer to the Architectural section under "RECORD DRAWINGS" for further requirements and procedures.

END OF SECTION 260100

SECTION 260519 - CONDUCTORS AND CABLES



PART 1 - GENERAL

1.1 SUMMARY

- A. This Section includes building wires and cables and associated connectors, splices, and terminations for wiring systems rated 600 V and less.

1.2 SUBMITTALS

- A. Field quality-control test reports.

1.3 QUALITY ASSURANCE

- A. Electrical Components, Devices, and Accessories: Listed and labeled as defined in NFPA 70, Article 100, by a testing agency acceptable to authorities having jurisdiction, and marked for intended use.
- B. Comply with NFPA 70.

PART 2 - PRODUCTS

2.1 MANUFACTURERS

- A. In other Part 2 articles where subparagraph titles below introduce lists, the following requirements apply for product selection:
 - 1. Manufacturers: Subject to compliance with requirements, provide products by the manufacturers specified.

2.2 CONDUCTORS AND CABLES

- A. Manufacturers:
 - 1. American Insulated Wire Corp.; a Leviton Company.
 - 2. General Cable Corporation.
 - 3. Southwire Company.
 - 4. AFC Cables
 - 5. Kaf Tech Cables
 - 6. Burndy Corp.
- B. Refer to Part 3 "Conductor and Insulation Applications" Article for insulation type, cable construction, and ratings.

- C. Conductor Material: Copper; solid conductor for No. 10 AWG and smaller, stranded for No. 8 AWG and larger.
- D. Conductor Insulation Types: Type THHN-THWN, and XHHW complying with NEMA WC 5 or 7.

2.3 CONNECTORS AND SPLICES

- A. Manufacturers:
 - 1. AFC Cable Systems, Inc.
 - 2. AMP Incorporated/Tyco International.
 - 3. Hubbell/Anderson.
 - 4. O-Z/Gedney; EGS Electrical Group LLC.
 - 5. 3M Company; Electrical Products Division.
- B. Description: Factory-fabricated connectors and splices of size, ampacity rating, material, type, and class for application and service indicated.

PART 3 - EXECUTION

3.1 CONDUCTOR AND INSULATION APPLICATIONS

- A. Service Entrance: Type THHN-THWN, single conductors in raceway.
- B. Feeders Concealed in Ceilings, Walls, and Partitions: Type THHN-THWN, single conductors in raceway.
- C. Feeders Concealed in Concrete, below Slabs-on-Grade, and in Crawlspace: Type THHN-THWN, single conductors in raceway.
- D. Exposed Branch Circuits, including in Crawlspace: Type THHN-THWN, single conductors in raceway.
- E. Branch Circuits Concealed in Ceilings, Walls, and Partitions: .
- F. Branch Circuits Concealed in Concrete and below Slabs-on-Grade: Type THHN-THWN, single conductors in raceway.
- G. Cord Drops and Portable Appliance Connections: Type SO, hard service cord.
- H. Fire Alarm Circuits: Type THHN-THWN, in raceway.
- I. Class 1 Control Circuits: Type THHN-THWN, in raceway.
- J. Class 2 Control Circuits: Type THHN-THWN, in raceway.

3.2 INSTALLATION

- A. Conceal cables in finished walls, ceilings, and floors, unless otherwise indicated.
- B. Use manufacturer-approved pulling compound or lubricant where necessary; compound used must not deteriorate conductor or insulation. Do not exceed manufacturer's recommended maximum pulling tensions and sidewall pressure values.
- C. Use pulling means, including fish tape, cable, rope, and basket-weave wire/cable grips that will not damage cables or raceway.
- D. Install exposed cables parallel and perpendicular to surfaces of exposed structural members, and follow surface contours where possible.
- E. Support cables according to Division 26 Section "Basic Electrical Materials and Methods."
- F. Seal around cables penetrating fire-rated elements according to Division 7 Section "Through-Penetration Firestop Systems."
- G. Identify and color-code conductors and cables according to Division 26 Section "Basic Electrical Materials and Methods Electrical Identification."
- H. Make splices and taps that are compatible with conductor material and that possess equivalent or better mechanical strength and insulation ratings than unspliced conductors.
- I. Wiring at Outlets: Install conductor at each outlet, with at least 8 inches of slack.

3.3 FIELD QUALITY CONTROL

- A. Testing: Perform each electrical test and visual and mechanical inspection stated in NETA ATS, Section 7.3.1. Certify compliance with test parameters.
- B. Test Reports: Prepare a written report to record the following:
 - 1. Test procedures used.
 - 2. Test results that comply with requirements.
 - 3. Test results that do not comply with requirements and corrective action taken to achieve compliance with requirements.

END OF SECTION 260519

SECTION 260526 - GROUNDING AND BONDING



PART 1 - GENERAL

1.1 RELATED DOCUMENTS

- A. Drawings and general provisions of the Contract, including General and Supplementary Conditions and Division 1 Specification Sections, apply to this Section.

1.2 SUMMARY

- A. This Section includes grounding of electrical systems and equipment. Grounding requirements specified in this Section may be supplemented by special requirements of systems described in other Sections.

1.3 SUBMITTALS

- A. Product Data: For each type of product indicated.
- B. Product Data: For the following:
 - 1. Ground rods.
- B. Qualification Data: For firms and persons specified in "Quality Assurance" Article.
- C. Field Test Reports: Submit written test reports to include the following:
 - 1. Test procedures used.
 - 2. Test results that comply with requirements.
 - 3. Results of failed tests and corrective action taken to achieve test results that comply with requirements.

1.4 QUALITY ASSURANCE

- A. Testing Agency Qualifications: Testing agency as defined by OSHA in 29 CFR 1910.7 or a member company of the InterNational Electrical Testing Association and that is acceptable to authorities having jurisdiction.
 - 1. Testing Agency's Field Supervisor: Person currently certified by the InterNational Electrical Testing Association to supervise on-site testing specified in Part 3.
- B. Electrical Components, Devices, and Accessories: Listed and labeled as defined in NFPA 70, Article 100, by a testing agency acceptable to authorities having jurisdiction, and marked for intended use.
 - 1. Comply with UL 467.

- C. Comply with NFPA 70; for overhead-line construction and medium-voltage underground construction, comply with IEEE C2.
- D. Comply with NFPA 780 and UL 96 when interconnecting with lightning protection system.

PART 2 - PRODUCTS

2.1 MANUFACTURERS

- A. Manufacturers: Subject to compliance with requirements, provide products by one of the following:
 - 1. Grounding Conductors, Cables, Connectors, and Rods:
 - a. Apache Grounding/Erico Inc.
 - b. Boggs, Inc.
 - c. Chance/Hubbell.
 - d. Copperweld Corp.
 - e. Dossert Corp.
 - f. Erico Inc.; Electrical Products Group.
 - g. Framatome Connectors/Burndy Electrical.
 - h. Galvan Industries, Inc.
 - i. Ideal Industries, Inc.
 - j. ILSCO.
 - k. Kearney/Cooper Power Systems.
 - l. Korns: C. C. Korns Co.; Division of Robroy Industries.
 - m. Lyncole XIT Grounding.
 - n. O-Z/Gedney Co.; a business of the EGS Electrical Group.
 - o. Raco, Inc.; Division of Hubbell.
 - p. Salisbury: W. H. Salisbury & Co.
 - q. Superior Grounding Systems, Inc.
 - r. Thomas & Betts, Electrical.

2.2 GROUNDING CONDUCTORS

- A. For insulated conductors, comply with Division 26 Section "Conductors and Cables."
- B. Material: Copper.
- C. Equipment Grounding Conductors: Insulated with green-colored insulation.
- D. Isolated Ground Conductors: Insulated with green-colored insulation with yellow stripe. On feeders with isolated ground, use colored tape, alternating bands of green and yellow tape to provide a minimum of three bands of green and two bands of yellow.
- D. Grounding Electrode Conductors: Stranded cable.
- E. Underground Conductors: Bare, tinned, stranded, unless otherwise indicated.

- F. Bare Copper Conductors: Comply with the following:
 - 1. Solid Conductors: ASTM B 3.
 - 2. Assembly of Stranded Conductors: ASTM B 8.
 - 3. Tinned Conductors: ASTM B 33.

- G. Copper Bonding Conductors: As follows:
 - 1. Bonding Cable: 28 kcmil, 14 strands of No. 17 AWG copper conductor, 1/4 inch in diameter.
 - 2. Bonding Conductor: No. 4 or No. 6 AWG, stranded copper conductor.
 - 3. Bonding Jumper: Bare copper tape, braided bare copper conductors, terminated with copper ferrules; 1-5/8 inches wide and 1/16 inch thick.
 - 4. Tinned Bonding Jumper: Tinned-copper tape, braided copper conductors, terminated with copper ferrules; 1-5/8 inches wide and 1/16 inch thick.

- H. Grounding Bus: Bare, annealed copper bars of rectangular cross section, with insulators.

2.3 CONNECTOR PRODUCTS

- A. Comply with IEEE 837 and UL 467; listed for use for specific types, sizes, and combinations of conductors and connected items.
- B. Bolted Connectors: Bolted-pressure-type connectors, or compression type.
- C. Welded Connectors: Exothermic-welded type, in kit form, and selected per manufacturer's written instructions.

2.4 GROUNDING ELECTRODES

- A. Ground Rods: Sectional type; **copper-clad** steel.
 - 1. Size: 3/4 by 120 inches in diameter.

PART 3 - EXECUTION

3.1 APPLICATION

- A. Use only copper conductors for both insulated and bare grounding conductors in direct contact with earth, concrete, masonry, crushed stone, and similar materials.
- B. In raceways, use insulated equipment grounding conductors.
- C. Exothermic-Welded Connections: Use for connections to structural steel, ground rods and for underground connections, except those at test wells.

- D. Equipment Grounding Conductor Terminations: Use bolted pressure clamps.
- E. Ground Rod Clamps at Test Wells: Use bolted pressure clamps with at least two bolts.
- F. Grounding Bus: Install in electrical and telephone equipment rooms, in rooms housing service equipment, and elsewhere as indicated.
 - 1. Use insulated spacer; space 1 inch from wall and support from wall 18 inches above finished floor, unless otherwise indicated.
- G. Underground Grounding Conductors: Use copper conductor, No. 2/0 AWG minimum. Bury at least 24 inches below grade

3.2 EQUIPMENT GROUNDING CONDUCTORS

- A. Comply with NFPA 70, Article 250, for types, sizes, and quantities of equipment grounding conductors, unless specific types, larger sizes, or more conductors than required by NFPA 70 are indicated.
- B. Install equipment grounding conductors in all feeders and branch circuits.
- C. Install insulated equipment grounding conductor with circuit conductors for the following items, in addition to those required by NEC:
 - 1. Feeders and branch circuits.
 - 2. Lighting circuits.
 - 3. Receptacle circuits.
 - 4. Single-phase motor and appliance branch circuits.
 - 5. Three-phase motor and appliance branch circuits.
 - 6. Flexible raceway runs.
 - 7. Armored and metal-clad cable runs.
 - 8. Fixture Whips regardless of length.
- D. Computer Outlet Circuits: Install insulated equipment grounding conductor in branch-circuit runs from computer-area power panels or power-distribution units.
- E. Isolated Grounding Receptacle Circuits: Install an insulated equipment grounding conductor connected to the receptacle grounding terminal. Isolate grounding conductor from raceway and from panelboard grounding terminals. Terminate at equipment grounding conductor terminal of the applicable derived system or service, unless otherwise indicated.
- F. Isolated Equipment Enclosure Circuits: For designated equipment supplied by a branch circuit or feeder, isolate equipment enclosure from supply raceway with a nonmetallic raceway fitting listed for the purpose. Install fitting where raceway enters enclosure, and install a separate equipment grounding conductor. Isolate equipment grounding conductor from raceway and from panelboard grounding terminals. Terminate at equipment grounding conductor terminal of the applicable derived system or service, unless otherwise indicated.
- G. Nonmetallic Raceways: Install an equipment grounding conductor in nonmetallic raceways unless they are designated for telephone or data cables.

- H. **Signal and Communication Systems:** For telephone, alarm, voice and data, and other communication systems, provide No. 6 AWG minimum insulated grounding conductor in raceway from grounding electrode system to each service location, terminal cabinet, wiring closet, and central equipment location
 - 1. **Service and Central Equipment Locations and Wiring Closets:** Terminate grounding conductor on a 12 slot copper grounding bus.
 - 2. **Terminal Cabinets:** Terminate grounding conductor on cabinet grounding terminal.
- I. **Metal Poles Supporting Outdoor Lighting Fixtures:** Provide a grounding electrode in addition to installing a separate equipment grounding conductor with supply branch-circuit conductors.

3.3 INSTALLATION

- A. **Ground Rods:**
 - 1. Drive ground rods until tops are 2 inches below finished floor or final grade, unless otherwise indicated. Provide test well at ground rod at main service location flush with concrete.
 - 2. Interconnect ground rods with grounding electrode conductors. Use exothermic welds, except at test wells and as otherwise indicated. Make connections without exposing steel or damaging copper coating.
- B. **Grounding Conductors:** Route along shortest and straightest paths possible, unless otherwise indicated. Avoid obstructing access or placing conductors where they may be subjected to strain, impact, or damage.
- C. **Bonding Straps and Jumpers:** Install so vibration by equipment mounted on vibration isolation hangers and supports is not transmitted to rigidly mounted equipment. Use exothermic-welded connectors for outdoor locations, unless a disconnect-type connection is required; then, use a bolted clamp. Bond straps directly to the basic structure taking care not to penetrate any adjacent parts. Install straps only in locations accessible for maintenance.
- D. **Metal Water Service Pipe:** Provide insulated copper grounding conductors, in conduit, from building's main service equipment, or grounding bus, to main metal water service entrances to building. Connect grounding conductors to main metal water service pipes by grounding clamp connectors. Where a dielectric main water fitting is installed, connect grounding conductor to street side of fitting. Bond metal grounding conductor conduit or sleeve to conductor at each end.
- E. **Water Meter Piping:** Use braided-type bonding jumpers to electrically bypass water meters. Connect to pipe with grounding clamp connectors.
- F. **Bond each aboveground portion of gas piping system upstream from equipment shutoff valve.**
- G. **Install one test well for each service at the ground rod electrically closest to the service entrance. Set top of well flush with finished grade or floor.**

Propose location by contractor for engineer review in counterpoise shop drawings.

3.4 CONNECTIONS

- A. **General:** Make connections so galvanic action or electrolysis possibility is minimized. Select connectors, connection hardware, conductors, and connection methods so metals in direct contact will be galvanically compatible.
 - 1. Use electroplated or hot-tin-coated materials to ensure high conductivity and to make contact points closer to order of galvanic series.
 - 2. Make connections with clean, bare metal at points of contact.
 - 3. Make aluminum-to-steel connections with stainless-steel separators and mechanical clamps.
 - 4. Make aluminum-to-galvanized steel connections with tin-plated copper jumpers and mechanical clamps.
 - 5. Coat and seal connections having dissimilar metals with inert material to prevent future penetration of moisture to contact surfaces.
- B. **Exothermic-Welded Connections:** Comply with manufacturer's written instructions. Welds that are puffed up or that show convex surfaces indicating improper cleaning are not acceptable.
- C. **Equipment Grounding Conductor Terminations:** For No. 8 AWG and larger, use pressure-type grounding lugs. No. 10 AWG and smaller grounding conductors may be terminated with winged pressure-type connectors.
- D. **Noncontact Metal Raceway Terminations:** If metallic raceways terminate at metal housings without mechanical and electrical connection to housing, terminate each conduit with a grounding bushing. Connect grounding bushings with a bare grounding conductor to grounding bus or terminal in housing. Bond electrically noncontinuous conduits at entrances and exits with grounding bushings and bare grounding conductors, unless otherwise indicated.
- E. **Connections at Test Wells:** Use compression-type connectors on conductors and make bolted-and clamped-type connections between conductors and ground rods.
- F. **Tighten screws and bolts for grounding and bonding connectors and terminals** according to manufacturer's published torque-tightening values. If manufacturer's torque values are not indicated, use those specified in UL 486A.
- G. **Compression-Type Connections:** Use hydraulic compression tools to provide correct circumferential pressure for compression connectors. Use tools and dies recommended by connector manufacturer. Provide embossing die code or other standard method to make a visible indication that a connector has been adequately compressed on grounding conductor.
- H. **Moisture Protection:** If insulated grounding conductors are connected to ground rods or grounding buses, insulate entire area of connection and seal against moisture penetration of insulation and cable.

3.5 FIELD QUALITY CONTROL

- A. **Testing:** Perform the following field quality-control testing:

1. After installing grounding system but before permanent electrical circuitry has been energized, test for compliance with requirements.
2. Test completed grounding system at each location where a maximum ground-resistance level is specified, at service disconnect enclosure grounding terminal, and at ground test wells. Measure ground resistance not less than two full days after the last trace of precipitation, and without the soil being moistened by any means other than natural drainage or seepage and without chemical treatment or other artificial means of reducing natural ground resistance. Perform tests, by the fall-of-potential method according to IEEE 81.
3. Provide drawings locating each ground rod and ground rod assembly and other grounding electrodes, identify each by letter in alphabetical order, and key to the record of tests and observations. Include the number of rods driven and their depth at each location and include observations of weather and other phenomena that may affect test results. Describe measures taken to improve test results.
 - a. Equipment Rated 500 kVA and Less: 10 ohms.
 - b. Equipment Rated 500 to 1000 kVA: 5 ohms.
 - c. Equipment Rated More Than 1000 kVA: 3 ohms.
 - d. Substations and Pad-Mounted Switching Equipment: 5 ohms.
 - e. Manhole Grounds: 10 ohms.
4. Excessive Ground Resistance: If resistance to ground exceeds specified values, notify Architect promptly and include recommendations to reduce ground resistance.

3.6 GRADING AND PLANTING

- A. Restore surface features, including vegetation, at areas disturbed by Work of this Section. Reestablish original grades, unless otherwise indicated. If sod has been removed, replace it as soon as possible after backfilling is completed. Restore areas disturbed by trenching, storing of dirt, cable laying, and other activities to their original condition. Include application of topsoil, fertilizer, lime, seed, sod, sprig, and mulch. Comply with Division 2 Section "Landscaping." Maintain restored surfaces. Restore disturbed paving as indicated.

END OF SECTION 260526

SECTION 260533 - RACEWAYS AND BOXES



PART 1 - GENERAL

1.1 RELATED DOCUMENTS

- A. Drawings and general provisions of the Contract, including General and Supplementary Conditions and Division 1 Specification Sections, apply to this Section.

1.2 SUMMARY

- A. This Section includes raceways, fittings, boxes, enclosures, and cabinets for electrical wiring.
- B. Related Sections include the following:
 - 1. Division 26 Section "Basic Electrical Materials and Methods" for supports, anchors, and identification products.
 - 2. Division 26 Section "Wiring Devices" for devices installed in boxes and for floor-box service fittings.

1.3 DEFINITIONS

- A. EMT: Electrical metallic tubing.
- B. ENT: Electrical nonmetallic tubing.
- C. FMC: Flexible metal conduit.
- D. IMC: Intermediate metal conduit.
- E. LFMC: Liquidtight flexible metal conduit.
- F. LFNC: Liquidtight flexible nonmetallic conduit.
- G. RNC: Rigid nonmetallic conduit.

1.4 SUBMITTALS

- A. Product Data: For surface raceways, wireways and fittings, floor boxes, hinged-cover enclosures, and cabinets.
- B. Shop Drawings: Show fabrication and installation details of components for raceways, fittings, boxes, enclosures, and cabinets.
- C. Coordination Drawings: Reflected ceiling plans drawn to scale and coordinating penetrations and ceiling-mounted items. Show the following:

1. Ceiling suspension assembly members.
2. Method of attaching hangers to building structure.
3. Size and location of initial access modules for acoustical tile.
4. Ceiling-mounted items including lighting fixtures, diffusers, grilles, speakers, sprinklers, access panels, and special moldings.

1.5 QUALITY ASSURANCE

- A. Electrical Components, Devices, and Accessories: Listed and labeled as defined in NFPA 70, Article 100, by a testing agency acceptable to authorities having jurisdiction, and marked for intended use.
- B. Comply with NFPA 70.

1.6 COORDINATION

- A. Coordinate layout and installation of raceways, boxes, enclosures, cabinets, and suspension system with other construction that penetrates ceilings or is supported by them, including light fixtures, HVAC equipment, fire-suppression system, and partition assemblies.

PART 2 - PRODUCTS

2.1 MANUFACTURERS

- A. In other Part 2 articles where subparagraph titles below introduce lists, the following requirements apply for product selection:
 1. Manufacturers: Subject to compliance with requirements, provide products by the manufacturers specified.

2.2 METAL CONDUIT AND TUBING

- A. Manufacturers:
 1. Grinnell Co./Tyco International; Allied Tube and Conduit Div.
 2. LTV Steel Tubular Products Company.
 3. O-Z Gedney; Unit of General Signal.
 4. Wheatland Tube Co.
- B. Rigid Steel Conduit: ANSI C80.1.
- C. Aluminum Rigid Conduit: ANSI C80.5.
- D. IMC: ANSI C80.6.

- E. Plastic-Coated Steel Conduit and Fittings: NEMA RN 1.
- F. Plastic-Coated IMC and Fittings: NEMA RN 1.
- G. EMT and Fittings: ANSI C80.3.
 - 1. Fittings: Compression type.
- H. FMC: Zinc-coated steel.
- I. LFMC: Flexible steel conduit with PVC jacket.
- J. Fittings: NEMA FB 1; compatible with conduit and tubing materials.

2.3 NONMETALLIC CONDUIT AND TUBING

A. Manufacturers:

- 1. American International.
- 2. Anamet Electrical, Inc.; Anaconda Metal Hose.
- 3. Arco Corp.
- 4. Cantex Inc.
- 5. Certainteed Corp.; Pipe & Plastics Group.
- 6. Condux International.
- 7. ElecSYS, Inc.
- 8. Lamson & Sessions; Carlon Electrical Products.
- 9. Manhattan/CDT/Cole-Flex.
- 10. RACO; Division of Hubbell, Inc.
- 11. Thomas & Betts Corporation.

- B. ENT: NEMA TC 13.
- C. RNC: NEMA TC 2, Schedule 40 and Schedule 80 PVC.
- D. ENT and RNC Fittings: NEMA TC 3; match to conduit or tubing type and material.
- E. LFNC: UL 1660.

2.4 METAL WIREWAYS

A. Manufacturers:

- 1. Hoffman.
- 2. Square D.
- 3. Wiegman

- B. Material and Construction: Sheet metal sized and shaped as indicated, NEMA 3R.

- C. Fittings and Accessories: Include couplings, offsets, elbows, expansion joints, adapters, hold-down straps, end caps, and other fittings to match and mate with wireways as required for complete system.
- D. Select features, unless otherwise indicated, as required to complete wiring system and to comply with NFPA 70.
- E. Wireway Covers: Screw-cover type.
- F. Finish: Manufacturer's standard enamel finish.

2.5 SURFACE RACEWAYS

- A. Surface Metal Raceways: Galvanized steel with snap-on covers. Finish with manufacturer's standard prime coating.
- B. Manufacturers:
 - 1. Airey-Thompson Sentinel Lighting; Wiremold Company (The).
 - 2. Thomas & Betts Corporation.
 - 3. Walker Systems, Inc.; Wiremold Company (The).
 - 4. Wiremold Company (The); Electrical Sales Division.
- C. Types, sizes, and channels as indicated and required for each application, with fittings that match and mate with raceways.

2.6 BOXES, ENCLOSURES, AND CABINETS

- A. Manufacturers:
 - 1. Cooper Crouse-Hinds; Div. of Cooper Industries, Inc.
 - 2. Emerson/General Signal; Appleton Electric Company.
 - 3. Erickson Electrical Equipment Co.
 - 4. Hoffman.
 - 5. Hubbell, Inc.; Killark Electric Manufacturing Co.
 - 6. O-Z/Gedney; Unit of General Signal.
 - 7. RACO; Division of Hubbell, Inc.
 - 8. Robroy Industries, Inc.; Enclosure Division.
 - 9. Scott Fetzer Co.; Adalet-PLM Division.
 - 10. Spring City Electrical Manufacturing Co.
 - 11. Thomas & Betts Corporation.
 - 12. Walker Systems, Inc.; Wiremold Company (The).
 - 13. Woodhead, Daniel Company; Woodhead Industries, Inc. Subsidiary.
- B. Sheet Metal Outlet and Device Boxes: NEMA OS 1.
- C. Cast-Metal Outlet and Device Boxes: NEMA FB 1, Type FD, with gasketed cover.

- D. Floor Boxes: Cast metal, fully adjustable, rectangular. On grade listed.
- E. Small Sheet Metal Pull and Junction Boxes: NEMA OS 1.
- F. Cast-Metal Pull and Junction Boxes: NEMA FB 1, cast aluminum with gasketed cover.
- G. Hinged-Cover Enclosures: EMA 250, Type 1, with continuous hinge cover and flush latch.
 - 1. Metal Enclosures: Steel, finished inside and out with manufacturer's standard enamel.
- H. Cabinets: NEMA 250, Type 1, galvanized steel box with removable interior panel and removable front, finished inside and out with manufacturer's standard enamel. Hinged door in front cover with flush latch and concealed hinge. Key latch to match panelboards. Include metal barriers to separate wiring of different systems and voltage and include accessory feet where required for freestanding equipment.

2.7 FACTORY FINISHES

- A. Finish: For raceway, enclosure, or cabinet components, provide manufacturer's standard prime-coat finish ready for field painting.

PART 3 - EXECUTION

3.1 RACEWAY APPLICATION

- A. Outdoors:
 - 1. Exposed: Rigid steel or IMC.
 - 2. Concealed: Rigid steel or IMC.
 - 3. Underground, Single Run: RNC.
 - 4. Underground, Grouped: RNC.
 - 5. Connection to Vibrating Equipment (Including Transformers and Hydraulic, Pneumatic, Electric Solenoid, or Motor-Driven Equipment): LFMC.
 - 6. Boxes and Enclosures: NEMA 250, Type 3R.
- B. Indoors:
 - 1. Exposed: EMT.
 - 2. Concealed: EMT.
 - 3. Connection to Vibrating Equipment (Including Transformers and Hydraulic, Pneumatic, Electric Solenoid, or Motor-Driven Equipment): FMC; except use LFMC in damp or wet locations.
 - 4. Damp or Wet Locations: Rigid steel conduit.
 - 5. Boxes and Enclosures: NEMA 250, Type 1, except as follows:
 - a. Damp or Wet Locations: NEMA 250, Type 4, stainless steel.
- C. Minimum Raceway Size: 1/2-inch trade size above grade, 3/4" C min below grade

- D. Raceway Fittings: Compatible with raceways and suitable for use and location.
 - 1. Intermediate Steel Conduit: Use threaded rigid steel conduit fittings, unless otherwise indicated.
- E. Do not install aluminum conduits embedded in or in contact with concrete unless properly protected where routed through or in concrete.

3.2 INSTALLATION

- A. Keep raceways at least 6 inches away from parallel runs of flues and steam or hot-water pipes. Install horizontal raceway runs above water and steam piping.
- B. Complete raceway installation before starting conductor installation.
- C. Support raceways as specified in Division 26 Section "Basic Electrical Materials and Methods."
- D. Install temporary closures to prevent foreign matter from entering raceways.
- E. Protect stub-ups from damage where conduits rise through floor slabs. Arrange so curved portions of bends are not visible above the finished slab.
- F. Make bends and offsets so ID is not reduced. Keep legs of bends in the same plane and keep straight legs of offsets parallel, unless otherwise indicated.
- G. Conceal conduit and EMT within finished walls, ceilings, and floors, unless otherwise indicated.
 - 1. Install concealed raceways with a minimum of bends in the shortest practical distance, considering type of building construction and obstructions, unless otherwise indicated.
- H. Raceways Below Slabs: Do not install raceways embedded in slabs.
 - 1. Secure raceways to reinforcing rods to prevent sagging or shifting, using stainless steel straps.
 - 2. Space raceways laterally to prevent voids in concrete.
 - 3. Run conduit larger than 1-inch trade size parallel or at right angles to main reinforcement. Where at right angles to reinforcement, place conduit close to slab support.
 - 4. Change from nonmetallic tubing to rigid steel conduit, or IMC before rising above the floor.
- I. Install exposed raceways parallel or at right angles to nearby surfaces or structural members and follow surface contours as much as possible.
 - 1. Run parallel or banked raceways together on common supports.
 - 2. Make parallel bends in parallel or banked runs. Use factory elbows only where elbows can be installed parallel; otherwise, provide field bends for parallel raceways.
- J. Join raceways with fittings designed and approved for that purpose and make joints tight.

1. Use insulating bushings to protect conductors.
- K. Terminations:
1. Where raceways are terminated with locknuts and bushings, align raceways to enter squarely and install locknuts with dished part against box. Use two locknuts, one inside and one outside box.
 2. Where raceways are terminated with threaded hubs, screw raceways or fittings tightly into hub so end bears against wire protection shoulder. Where chase nipples are used, align raceways so coupling is square to box; tighten chase nipple so no threads are exposed.
- L. Install pull wires in empty raceways. Use polypropylene or monofilament plastic line with not less than 200-lb tensile strength. Leave at least 12 inches of slack at each end of pull wire.
- M. Telephone and Signal System Raceways, 2-Inch Trade Size and Smaller: In addition to above requirements, install raceways in maximum lengths of 150 feet and with a maximum of two 90-degree bends or equivalent. Separate lengths with pull or junction boxes where necessary to comply with these requirements.
- N. Install raceway sealing fittings at suitable, approved, and accessible locations and fill them with UL-listed sealing compound. For concealed raceways, install each fitting in a flush steel box with a blank cover plate having a finish similar to that of adjacent plates or surfaces. Install raceway sealing fittings at the following points:
1. Where conduits pass from warm to cold locations, such as boundaries of refrigerated spaces.
 2. Where otherwise required by NFPA 70.
- O. Stub-up Connections: Extend conduits through concrete floor for connection to freestanding equipment. Install with an adjustable top or coupling threaded inside for plugs set flush with finished floor. Extend conductors to equipment with rigid steel conduit; FMC may be used 6 inches above the floor. Install screwdriver-operated, threaded plugs flush with floor for future equipment connections.
- P. Flexible Connections: Use maximum of 72 inches of flexible conduit for recessed and semirecessed lighting fixtures, install jbox above each fixture to transition from conduit to flex; for equipment subject to vibration, noise transmission, or movement; and for all motors. Use LFMC in damp or wet locations. Install separate ground conductor across flexible connections at all instances.
- Q. Surface Raceways: Install a separate, green, ground conductor in raceways from junction box supplying raceways to receptacle or fixture ground terminals.
- R. Set floor boxes level and flush with finished floor surface.
- S. Install hinged-cover enclosures and cabinets plumb. Support at each corner.

3.3 PROTECTION

- A. Provide final protection and maintain conditions that ensure coatings, finishes, and cabinets are without damage or deterioration at time of Substantial Completion.
 - 1. Repair damage to galvanized finishes with zinc-rich paint recommended by manufacturer.
 - 2. Repair damage to PVC or paint finishes with matching touchup coating recommended by manufacturer.

3.4 CLEANING

- A. After completing installation of exposed, factory-finished raceways and boxes, inspect exposed finishes and repair damaged finishes.

END OF SECTION 260533

SECTION 260553 - ELECTRICAL IDENTIFICATION



PART 1 - GENERAL

1.1 RELATED DOCUMENTS

- A. Drawings and general provisions of the Contract, including General and Supplementary Conditions and Division 1 Specification Sections, apply to this Section.

1.2 SUMMARY

- A. This Section includes electrical identification materials and devices required to comply with ANSI C2, NFPA 70, OSHA standards, and authorities having jurisdiction.

1.3 SUBMITTALS

- A. Product Data: For each electrical identification product indicated.
- B. Schedule of Nomenclature: An index of electrical equipment and system components used in identification signs and labels.
- C. Samples: For each type of label and sign to illustrate color, lettering style, and graphic features of identification products.

1.4 QUALITY ASSURANCE

- A. Comply with ANSI C2.
- B. Comply with NFPA 70.
- C. Comply with ANSI A13.1 and NFPA 70 for color-coding.

PART 2 - PRODUCTS

2.1 RACEWAY AND CABLE LABELS

- A. Comply with ANSI A13.1, Table 3, for minimum size of letters for legend and for minimum length of color field for each raceway and cable size.
 - 1. Color: Black letters on orange field.
 - 2. Legend: Indicates voltage and service.
- B. Adhesive Labels: Preprinted, flexible, self-adhesive vinyl with legend overlaminated with a clear, weather- and chemical-resistant coating.

- C. Underground-Line Warning Tape: Permanent, bright-colored, continuous-printed, vinyl tape.
 - 1. Not less than 6 inches wide by 4 mils thick.
 - 2. Compounded for permanent direct-burial service.
 - 3. Embedded continuous metallic strip or core.
 - 4. Printed legend indicating type of underground line.
- D. Tape Markers: Vinyl or vinyl-cloth, self-adhesive, wraparound type with preprinted numbers and letters.
- E. Aluminum, Wraparound Marker Bands: Bands cut from 0.014-inch- thick aluminum sheet, with stamped or embossed legend, and fitted with slots or ears for permanently securing around wire or cable jacket or around groups of conductors.
- F. Plasticized Card-Stock Tags: Vinyl cloth with preprinted and field-printed legends. Orange background, unless otherwise indicated, with eyelet for fastener.

2.2 NAMEPLATES AND SIGNS

- A. Safety Signs: Comply with 29 CFR, Chapter XVII, Part 1910.145.
- B. Engraved Plastic Nameplates and Signs: Engraving stock, melamine plastic laminate, minimum 1/16 inch thick for signs up to 20 sq. in. and 1/8 inch thick for larger sizes.
 - 1. Engraved legend with black letters on white face.
 - 2. Punched or drilled for mechanical fasteners.
- C. Exterior, Metal-Backed, Butyrate Signs: Weather-resistant, nonfading, preprinted, cellulose-acetate butyrate signs with 0.0396-inch galvanized-steel backing; and with colors, legend, and size required for the application. 1/4-inch grommets in corners for mounting.
- D. Fasteners for Nameplates and Signs: Self-tapping, stainless-steel screws or No. 10/32, stainless-steel machine screws with nuts and flat and lock washers.

2.3 MISCELLANEOUS IDENTIFICATION PRODUCTS

- A. Cable Ties: Fungus-inert, self-extinguishing, one-piece, self-locking, Type 6/6 nylon cable ties.
 - 1. Minimum Width: 3/16 inch.
 - 2. Tensile Strength: 50 lb minimum.
 - 3. Temperature Range: Minus 40 to plus 185 deg F.
 - 4. Color: According to color-coding.
- B. Paint: Formulated for the type of surface and intended use.
 - 1. Primer for Galvanized Metal: Single-component acrylic vehicle formulated for galvanized surfaces.

2. Primer for Concrete Masonry Units: Heavy-duty-resin block filler.
3. Primer for Concrete: Clear, alkali-resistant, binder-type sealer.
4. Enamel: Silicone-alkyd or alkyd urethane as recommended by primer manufacturer.

PART 3 - EXECUTION

3.1 INSTALLATION

- A. Identification Materials and Devices: Install at locations for most convenient viewing without interference with operation and maintenance of equipment.
- B. Lettering, Colors, and Graphics: Coordinate names, abbreviations, colors, and other designations with corresponding designations in the Contract Documents or with those required by codes and standards. Use consistent designations throughout Project.
- C. Sequence of Work: If identification is applied to surfaces that require finish, install identification after completing finish work.
- D. Install painted identification according to manufacturer's written instructions and as follows:
 1. Clean surfaces of dust, loose material, and oily films before painting.
 2. Prime surfaces using type of primer specified for surface.
 3. Apply one intermediate and one finish coat of enamel.
- E. Color Banding Raceways and Exposed Cables: Band exposed and accessible raceways of the systems listed below:
 1. Bands: Pretensioned, wraparound plastic sleeves; colored adhesive tape; or a combination of both. Make each color band 2 inches wide, completely encircling conduit, and place adjacent bands of two-color markings in contact, side by side.
 2. Band Locations: At changes in direction, at penetrations of walls and floors, at 50-foot maximum intervals in straight runs, and at 25-foot maximum intervals in congested areas.
- F. Caution Labels for Indoor Boxes and Enclosures for Power and Lighting: Install pressure-sensitive, self-adhesive labels identifying system voltage with black letters on orange background. Install on exterior of door or cover.
- G. Circuit Identification Labels on Boxes: Install labels externally.
 1. Exposed Boxes: Pressure-sensitive, self-adhesive plastic label on cover.
 2. Concealed Boxes: Plasticized card-stock tags.
 3. Labeling Legend: Permanent, waterproof listing of panel and circuit number or equivalent including voltage.
 4. Paint Fire Alarm junction box covers red
- H. Paths of Underground Electrical Lines: During trench backfilling, for exterior underground power, control, signal, and communication lines, install continuous underground plastic line marker located directly above line at 6 to 8 inches below finished grade. Where width of multiple lines installed in a common trench or concrete envelope does not exceed 16 inches

- overall, use a single line marker. Install line marker for underground wiring, both direct-buried cables and cables in raceway.
- I. Color-Coding of Secondary Phase Conductors: Use the following colors for service, feeder and branch-circuit phase conductors:
1. 208/120-V and 240/120-V Conductors:
 - a. Phase A: Black.
 - b. Phase B: Red.
 - c. Phase C: Blue.
 - d. Neutral: White.
 2. Factory apply color the entire length of conductors, except the following field-applied, color-coding methods may be used instead of factory-coded wire for sizes larger than No. 10 AWG:
 - a. Colored, pressure-sensitive plastic tape in half-lapped turns for a distance of 6 inches from terminal points and in boxes where splices or taps are made. Apply last two turns of tape with no tension to prevent possible unwinding. Use 1-inch-wide tape in colors specified. Adjust tape bands to avoid obscuring cable identification markings.
 - b. Colored cable ties applied in groups of three ties of specified color to each wire at each terminal or splice point starting 3 inches from the terminal and spaced 3 inches apart. Apply with a special tool or pliers, tighten to a snug fit, and cut off excess length.
- J. Power-Circuit Identification: Metal tags or aluminum, wraparound marker bands for cables, feeders, and power circuits in vaults, pull and junction boxes, manholes, and switchboard rooms.
1. Legend: 1/4-inch- steel letter and number stamping or embossing with legend corresponding to indicated circuit designations.
 2. Tag Fasteners: Nylon cable ties.
 3. Band Fasteners: Integral ears.
- K. Apply identification to conductors as follows:
1. Conductors to Be Extended in the Future: Indicate source and circuit numbers.
 2. Multiple Power or Lighting Circuits in the Same Enclosure: Identify each conductor with source, voltage, circuit number, and phase. Use color-coding to identify circuits' voltage and phase.
 3. Multiple Control and Communication Circuits in the Same Enclosure: Identify each conductor by its system and circuit designation. Use a consistent system of tags, color-coding, or cable marking tape.
- L. Apply warning, caution, and instruction signs as follows:
1. Warnings, Cautions, and Instructions: Install to ensure safe operation and maintenance of electrical systems and of items to which they connect. Install engraved plastic-laminated instruction signs with approved legend where instructions are needed

- for system or equipment operation. Install metal-backed butyrate signs for outdoor items.
2. **Emergency Operation:** Install engraved laminated signs with white legend on red background with minimum 3/8-inch- high lettering for emergency instructions on power transfer, load shedding, and other emergency operations.
- M. **Equipment Identification Labels:** Engraved plastic laminate. Install on each unit of equipment, including central or master unit of each system. This includes power, lighting, communication, signal, and alarm systems, unless units are specified with their own self-explanatory identification. Unless otherwise indicated, provide a single line of text with 1/2-inch- high lettering on 1-1/2-inch- high label; where two lines of text are required, use labels 2 inches high. Use white lettering on black field. Apply labels for each unit of the following categories of equipment using mechanical fasteners:
1. Panelboards, electrical cabinets, and enclosures.
 2. Access doors and panels for concealed electrical items.
 3. Electrical switchgear and switchboards.
 4. Disconnect switches.
 5. Enclosed circuit breakers.
 6. Power transfer equipment.
 7. Contactors.
 8. Dimmers.
 9. Control devices.
 10. Transformers.

END OF SECTION 260553

SECTION 260923 - LIGHTING CONTROL DEVICES



PART 1 - GENERAL

1.1 RELATED DOCUMENTS

- A. Drawings and general provisions of the Contract, including General and Supplementary Conditions and Division 1 Specification Sections, apply to this Section.

1.2 SUMMARY

- A. This Section includes the following lighting control devices:
 - 1. Time switches.
 - 2. Outdoor and indoor photoelectric switches.
 - 3. Switch-box occupancy sensors.
 - 4. Indoor occupancy sensors.
 - 5. Outdoor motion sensors.
 - 6. Multipole contactors.
- B. Related Sections include the following:
 - 1. Division 26 Section "Wiring Devices" for wall-box dimmers and manual light switches.

1.3 DEFINITIONS

- A. LED: Light-emitting diode.
- B. PIR: Passive infrared.

1.4 SUBMITTALS

- A. Product Data: For each type of product indicated.
- B. Shop Drawings: Show installation details for occupancy and light-level sensors.
 - 1. Lighting plan showing location, orientation, and coverage area of each sensor.
 - 2. Interconnection diagrams showing field-installed wiring.
- C. Field quality-control test reports.
- D. Operation and Maintenance Data: For each type of product to include in emergency, operation, and maintenance manuals.

1.5 QUALITY ASSURANCE

- A. Electrical Components, Devices, and Accessories: Listed and labeled as defined in NFPA 70, Article 100, by a testing agency acceptable to authorities having jurisdiction, and marked for intended use.

1.6 COORDINATION

- A. Coordinate layout and installation of ceiling-mounted devices with other construction that penetrates ceilings or is supported by them, including light fixtures, HVAC equipment, fire-suppression system, and partition assemblies.

PART 2 - PRODUCTS

2.1 MANUFACTURERS

- A. In other Part 2 articles where titles below introduce lists, the following requirements apply to product selection:
 - 1. Manufacturers: Subject to compliance with requirements, provide products by one of the manufacturers specified.

2.2 GENERAL LIGHTING CONTROL DEVICE REQUIREMENTS

- A. Line-Voltage Surge Protection: An integral part of the devices for 120- and 277-V solid-state equipment. For devices without integral line-voltage surge protection, field-mounting surge protection shall comply with IEEE C62.41 and with UL 1449.

2.3 TIME SWITCHES

- A. Manufacturers:
 - 1. Area Lighting Research, Inc.
 - 2. Fisher Pierce.
 - 3. Grasslin Controls Corporation.
 - 4. Intermatic, Inc.
 - 5. Leviton Mfg. Company Inc.
 - 6. Lightolier Controls; a Genlyte Company.
 - 7. Lithonia Lighting.
 - 8. Paragon Electric Co.
 - 9. Square D.
 - 10. TORK.
 - 11. Touchplate Technologies, Inc.
 - 12. Watt Stopper (The).

- B. Digital Time Switches: Electronic, solid-state programmable units with alphanumeric display complying with UL 917.
 - 1. Contact Configuration: As indicated.
 - 2. Contact Rating: As indicated.
 - 3. Program: Single channel, 2 on-off set points on a 24-hour schedule with skip-a-day weekly schedule.
 - 4. Circuitry: Allow connection of a photoelectric relay as substitute for on and off function of a program.
 - 5. Astronomical Time: All channels.
 - 6. Battery Backup: For schedules and time clock.

2.4 OUTDOOR PHOTOELECTRIC SWITCHES

A. Manufacturers:

- 1. Area Lighting Research, Inc.
- 2. Fisher Pierce.
- 3. Grasslin Controls Corporation.
- 4. Intermatic, Inc.
- 5. Lithonia Lighting.
- 6. Novitas, Inc.
- 7. Paragon Electric Co.
- 8. Square D.
- 9. TORK.
- 10. Touchplate Technologies, Inc.
- 11. Watt Stopper (The).

- B. Description: Solid state, with DPST dry contacts rated for 1800-VA tungsten or 1000-VA inductive, to operate connected relay, contactor coils, microprocessor input, and complying with UL 773A.

- 1. Light-Level Monitoring Range: 1.5 to 10 fc, with an adjustment for turn-on and turn-off levels within that range, and a directional lens in front of photocell to prevent fixed light sources from causing turn-off.
- 2. Time Delay: 15-second minimum, to prevent false operation.
- 3. Surge Protection: Metal-oxide varistor type, complying with IEEE C62.41 for Category A1 locations.
- 4. Mounting: Twist lock complying with IEEE C136.10, with base-and-stem mounting or stem-and-swivel mounting accessories as required to direct sensor to the North sky exposure.

2.5 INDOOR PHOTOELECTRIC SWITCHES- where specified

A. Manufacturers:

- 1. Allen-Bradley/Rockwell Automation.
- 2. Area Lighting Research, Inc.
- 3. Cutler-Hammer; Eaton Corporation.
- 4. Fisher Pierce.

5. Grasslin Controls Corporation.
 6. Intermatic, Inc.
 7. Lithonia Lighting.
 8. MicroLite Corporation.
 9. Novitas, Inc.
 10. Paragon Electric Co.
 11. Square D.
 12. TORK.
 13. Touchplate Technologies, Inc.
 14. Watt Stopper (The).
- B. Ceiling-Mounting Photoelectric Switch: Solid-state, light-level sensor unit, with separate relay unit mounted on luminaire, to detect changes in lighting levels that are perceived by the eye. Cadmium sulfide photoresistors are not acceptable.
1. Sensor Output: Contacts rated to operate the associated relay, complying with UL 773A. Sensor shall be powered from the relay unit.
 2. Relay Unit: Dry contacts rated for 20-A ballast load at 120- and 277-V ac, for 13-A tungsten at 120-V ac, and for 1 hp at 120-V ac. Power supply to sensor shall be 24-V dc, 150-mA, Class 2 power source as defined by NFPA 70.
 3. Light-Level Monitoring Range: 10 to 200 fc, with an adjustment for turn-on and turn-off levels within that range.
 4. Time Delay: Adjustable from 5 to 300 seconds to prevent cycling, with deadband adjustment.
 5. Indicator: Two LEDs to indicate the beginning of on and off cycles.

2.6 SWITCH-BOX OCCUPANCY SENSORS

A. Manufacturers:

1. Bryant Electric; a Hubbell Company.
 2. Hubbell Lighting Inc.
 3. Leviton Mfg. Company Inc.
 4. Lightolier Controls; a Genlyte Company.
 5. Lithonia Lighting.
 6. MYTECH Corporation.
 7. Novitas, Inc.
 8. RAB Electric Manufacturing, Inc.
 9. Sensor Switch, Inc.
 10. TORK.
 11. Unenco Electronics; a Hubbell Company.
 12. Watt Stopper (The).
- B. Description: PIR type with integral power-switching contacts rated for 800 W at 120-V ac, suitable for LED drivers, or 1/6-hp motors; and rated for 1000 W at 277-V ac, suitable for LED drivers, or 1/3-hp motors, minimum.

2.7 INDOOR OCCUPANCY SENSORS

A. Manufacturers:

1. Hubbell Lighting Inc.
2. Leviton Mfg. Company Inc.
3. Lithonia Lighting.
4. MYTECH Corporation.
5. Novitas, Inc.
6. RAB Electric Manufacturing, Inc.
7. Sensor Switch, Inc.
8. TORK.
9. Unenco Electronics; a Hubbell Company.
10. Watt Stopper (The).

B. General Description: Wall- or ceiling-mounting, solid-state units with a separate relay unit.

1. Operation: Unless otherwise indicated, turn lights on when covered area is occupied and off when unoccupied; with a time delay for turning lights off, adjustable over a minimum range of 1 to 30 minutes.
2. Sensor Output: Contacts rated to operate the connected relay, complying with UL 773A. Sensor shall be powered from the relay unit.
3. Relay Unit: Dry contacts rated for 20-A load at 120- and 277-V ac, and for 1 hp at 120-V ac. Power supply to sensor shall be 24-V dc, 150-mA, Class 2 power source as defined by NFPA 70.
4. Mounting:
 - a. Sensor: Suitable for mounting in any position on a standard outlet box.
 - b. Relay: Externally mounted through a 1/2-inch knockout in a standard electrical enclosure.
 - c. Time-Delay and Sensitivity Adjustments: Recessed and concealed behind hinged door.
5. Indicator: LED, to show when motion is being detected during testing and normal operation of the sensor.
6. Bypass Switch: Override the on function in case of sensor failure.
7. Automatic Light-Level Sensor: Adjustable from 2 to 200 fc; keeps lighting off when selected lighting level is present.
8. FailSafe: In case of sensor failure, lighting fixtures shall remain on.

C. Dual-Technology Type: Ceiling mounting; detect occupancy by using a combination of PIR and ultrasonic detection methods in area of coverage. Particular technology or combination of technologies that controls on and off functions shall be selectable in the field by operating controls on unit.

1. Sensitivity Adjustment: Separate for each sensing technology.
2. Detector Sensitivity: Detect occurrences of 6-inch minimum movement of any portion of a human body that presents a target of at least 36 sq. in., and detect a person of average size and weight moving at least 12 inches in either a horizontal or a vertical manner at an approximate speed of 12 inches/s.
3. Detection Coverage (Standard Room): Detect occupancy anywhere within a circular area of 1000 sq. ft. when mounted on a 96-inch- high ceiling.

2.8 OUTDOOR MOTION SENSORS (PIR)

A. Manufacturers:

1. Bryant Electric; a Hubbell Company.
2. Hubbell Lighting Inc.
3. Lithonia Lighting.
4. Paragon Electric Co.
5. RAB Electric Manufacturing, Inc.
6. TORK.
7. Watt Stopper (The).

B. General Description: Suitable for operation in ambient temperatures ranging from minus 40 deg F to 130 deg F, UL 773A rated as raintight.

1. Operation: Turn lights on when sensing infrared energy changes between background and moving body in area of coverage; with a time delay for turning lights off, adjustable over a minimum range of 1 to 15 minutes.
2. Sensor Output: Suitable for switching 300 W of tungsten load at 120- or 277-V ac. Lampholders shall comply with UL 1571 for wet locations.
3. Sensor Output: Contacts rated to operate the connected relay, complying with UL 773A. Sensor shall be powered from the relay unit.
4. Relay Unit: Dry contacts rated for 20-A ballast load at 120- and 277-V ac, for 13-A tungsten at 120-V ac, and for 1 hp at 120-V ac. Power supply to sensor shall be 24-V dc, 150-mA, Class 2 power source as defined by NFPA 70.
5. Mounting:
 - a. Sensor: Suitable for mounting in any position on a standard outdoor junction box.
 - b. Relay: Internally mounted in a standard weatherproof electrical enclosure.
 - c. Time-Delay and Sensitivity Adjustments: Recessed and concealed behind hinged door.
6. Indicator: LED, to show when motion is being detected during testing and normal operation of the sensor.
7. Bypass Switch: Override the on function in case of sensor failure.
8. Automatic Light-Level Sensor: Adjustable from 1 to 20 fc; keeps lighting off during daylight hours.

C. Detector Sensitivity: Detect occurrences of 6-inch minimum movement of any portion of a human body that presents a target of at least 36 sq. in.

2.9 MULTIPOLE CONTACTORS

A. Manufacturers:

1. Allen-Bradley/Rockwell Automation.
2. ASCO Power Technologies, LP; a division of Emerson Electric Co.
3. Cutler-Hammer; Eaton Corporation.
4. Fisher Pierce.

5. GE Industrial Systems; Total Lighting Control.
 6. Grasslin Controls Corporation.
 7. Hubbell Lighting Inc.
 8. Lithonia Lighting.
 9. MicroLite Corporation.
 10. TORK.
 11. Touchplate Technologies, Inc.
 12. Watt Stopper (The).
- B. Description: Electrically operated and electrically held, complying with NEMA ICS 2 and UL 508.
1. Current Rating for Switching: Listing or rating consistent with type of load served, including tungsten filament, inductive, and high-inrush ballast (ballast with 15 percent or less total harmonic distortion of normal load current).
 2. Control-Coil Voltage: Match control power source.

2.10 CONDUCTORS AND CABLES

- A. Power Wiring to Supply Side of Remote-Control Power Sources: Not smaller than No. 12 AWG, complying with Division 26 Section "Conductors and Cables."

PART 3 - EXECUTION

3.1 SENSOR INSTALLATION

- A. Install and aim sensors in locations to achieve at least 90 percent coverage of areas indicated. Do not exceed coverage limits specified in manufacturer's written instructions.

3.2 WIRING INSTALLATION

- A. Wiring Method: Comply with Division 26 Section "Conductors and Cables." Minimum conduit size shall be ½ inch.
- B. Wiring within Enclosures: Bundle, lace, and train conductors to terminal points. Separate power-limited and nonpower-limited conductors according to conductor manufacturer's written instructions.
- C. Install field-mounting transient voltage suppressors for lighting control devices in Category A locations that do not have integral line-voltage surge protection.
- D. Size conductors according to lighting control device manufacturer's written instructions, unless otherwise indicated.
- E. Splices, Taps, and Terminations: Make connections only on numbered terminal strips in junction, pull, and outlet boxes; terminal cabinets; and equipment enclosures.

- F. Tighten electrical connectors and terminals according to manufacturer's published torque-tightening values. If manufacturer's torque values are not indicated, use those specified in UL 486A and UL 486B.

3.3 IDENTIFICATION

- A. Identify components and power and control wiring according to Division 26 Section "Electrical Identification."
- B. Label time switches and contactors with a unique designation.

3.4 FIELD QUALITY CONTROL

- A. Perform the following field tests and inspections and prepare test reports:
 - 1. After installing time switches and sensors, and after electrical circuitry has been energized, adjust and test for compliance with requirements.
 - 2. Operational Test: Verify actuation of each sensor and adjust time delays.
- B. Remove and replace lighting control devices where test results indicate that they do not comply with specified requirements.
- C. Additional testing and inspecting, at Contractor's expense, will be performed to determine compliance of replaced or additional work with specified requirements.

3.5 ADJUSTING

- A. Occupancy Adjustments: When requested within 12 months of date of Substantial Completion, provide on-site assistance in adjusting sensors to suit actual occupied conditions. Provide up to two visits to site outside normal occupancy hours for this purpose.

END OF SECTION 260923

SECTION 262416 - PANELBOARDS



PART 1 - GENERAL

1.1 RELATED DOCUMENTS

- A. Drawings and general provisions of the Contract, including General and Supplementary Conditions and Division 1 Specification Sections, apply to this Section.

1.2 SUMMARY

- A. This Section includes the following:
 - 1. Distribution panelboards.
 - 2. Lighting and appliance branch-circuit panelboards.

1.3 DEFINITIONS

- A. EMI: Electromagnetic interference.
- B. GFCI: Ground-fault circuit interrupter.
- C. RFI: Radio-frequency interference.
- D. RMS: Root mean square.
- E. SPDT: Single pole, double throw.

1.4 SUBMITTALS

- A. Product Data: For each type of panelboard, overcurrent protective device, accessory, and component indicated. Include dimensions and manufacturers' technical data on features, performance, electrical characteristics, ratings, and finishes.
- B. Shop Drawings: For each panelboard and related equipment.
 - 1. Dimensioned plans, elevations, sections, and details. Show tabulations of installed devices, equipment features, and ratings. Include the following:
 - a. Enclosure types and details for types other than NEMA 250, Type 1.
 - b. Bus configuration, current, and voltage ratings.
 - c. Short-circuit current rating of panelboards and overcurrent protective devices.
 - d. Features, characteristics, ratings, and factory settings of individual overcurrent protective devices and auxiliary components.
 - 2. Wiring Diagrams: Power, signal, and control wiring.

- C. Field quality-control test reports including the following:
 - 1. Test procedures used.
 - 2. Test results that comply with requirements.
 - 3. Results of failed tests and corrective action taken to achieve test results that comply with requirements.
- D. Panelboard Schedules: For installation in panelboards. Submit final versions after load balancing.
- E. Operation and Maintenance Data: For panelboards and components to include in emergency, operation, and maintenance manuals.
 - 1. Manufacturer's written instructions for testing and adjusting overcurrent protective devices.
 - 2. Time-current curves, including selectable ranges for each type of overcurrent protective device.

1.5 QUALITY ASSURANCE

- A. Source Limitations: Obtain panelboards, overcurrent protective devices, components, and accessories through one source from a single manufacturer.
- B. Product Options: Drawings indicate size, profiles, and dimensional requirements of panelboards and are based on the specific system indicated
- C. Electrical Components, Devices, and Accessories: Listed and labeled as defined in NFPA 70, Article 100, by a testing agency acceptable to authorities having jurisdiction, and marked for intended use.
- D. Comply with NEMA PB 1.
- E. Comply with NFPA 70.

1.6 PROJECT CONDITIONS

- A. Environmental Limitations: Rate equipment for continuous operation under the following conditions, unless otherwise indicated:
 - 1. Ambient Temperature: Not exceeding 104 deg F.
 - 2. Altitude: Not exceeding 6600 feet.

1.7 COORDINATION

- A. Coordinate layout and installation of panelboards and components with other construction that penetrates walls or is supported by them, including electrical and other types of equipment, raceways, piping, and encumbrances to workspace clearance requirements.

1.8 EXTRA MATERIALS

- A. Furnish extra materials described below that match products installed and that are packaged with protective covering for storage and identified with labels describing contents.
 - 1. Keys: Six spares for each type of panelboard cabinet lock.

PART 2 - PRODUCTS

2.1 MANUFACTURERS

- A. Manufacturers: Subject to compliance with requirements, provide products by one of the following:
 - 1. Panelboards, Overcurrent Protective Devices, Controllers, Contactors, and Accessories:
 - a. General Electric Co.; Electrical Distribution & Protection Div.
 - b. Square D.
 - c. Eaton.

2.2 MANUFACTURED UNITS

- B. Enclosures: Flush- and surface-mounted cabinets. NEMA PB 1, Type 1.
 - 1. Rated for environmental conditions at installed location.
 - a. Outdoor Locations: NEMA 250, Type 3R.
 - b. Other Wet or Damp Indoor Locations: NEMA 250, Type 4.
 - 2. Front: Secured to box with concealed trim clamps. For surface-mounted fronts, match box dimensions; for flush-mounted fronts, overlap box.
 - 3. Finish: Manufacturer's standard enamel finish over corrosion-resistant treatment or primer coat.
 - 4. Directory Card: With transparent protective cover, mounted in metal frame, inside panelboard door.
- C. Phase and Ground Buses:
 - 1. Material: Hard-drawn copper, 98 percent conductivity.
 - 2. Equipment Ground Bus: Adequate for feeder and branch-circuit equipment ground conductors; bonded to box.
 - 3. Isolated Equipment Ground Bus: Adequate for branch-circuit equipment ground conductors; insulated from box.
- D. Conductor Connectors: Suitable for use with conductor material.
 - 1. Main and Neutral Lugs: Compression type.

2. Ground Lugs and Bus Configured Terminators: Compression type.
- E. Future Devices: Mounting brackets, bus connections, and necessary appurtenances required for future installation of devices.

2.3 PANELBOARD SHORT-CIRCUIT RATING

- A. Fully rated to interrupt symmetrical short-circuit current available at terminals.

2.4 DISTRIBUTION PANELBOARDS

- A. Doors: Secured with vault-type latch with tumbler lock; keyed alike. Omit for fused-switch panelboards.
- B. Main Overcurrent Protective Devices: Circuit breaker.
- C. Branch Overcurrent Protective Devices:
 1. For Circuit-Breaker Frame Sizes 125 A and Smaller: Bolt-on circuit breakers.
 2. For Circuit-Breaker Frame Sizes Larger Than 125 A: Bolt-on circuit breakers; plug-in circuit breakers where individual positive-locking device requires mechanical release for removal.

2.5 LIGHTING AND APPLIANCE BRANCH-CIRCUIT PANELBOARDS

- A. Branch Overcurrent Protective Devices: Bolt-on circuit breakers, replaceable without disturbing adjacent units.
- B. Doors: Concealed hinges; secured with flush latch with tumbler lock; keyed alike.

2.6 OVERCURRENT PROTECTIVE DEVICES

- A. Molded-Case Circuit Breaker: UL 489, with interrupting capacity to meet available fault currents.
 1. Thermal-Magnetic Circuit Breakers: Inverse time-current element for low-level overloads, and instantaneous magnetic trip element for short circuits. Adjustable magnetic trip setting for circuit-breaker frame sizes 250 A and larger.
 2. Adjustable Instantaneous-Trip Circuit Breakers: Magnetic trip element with front-mounted, field-adjustable trip setting.
 3. Electronic trip-unit circuit breakers shall have RMS sensing; field-replaceable rating plug; and with the following field-adjustable settings:
 - a. Instantaneous trip.
 - b. Long- and short-time pickup levels.
 - c. Long- and short-time time adjustments.
 - d. Ground-fault pickup level, time delay, and I^2t response.

4. Current-Limiting Circuit Breakers: Frame sizes 400 A and smaller; let-through ratings less than NEMA FU 1, RK-5.
 5. GFCI Circuit Breakers: Single- and two-pole configurations with 5-mA trip sensitivity.
- B. Molded-Case Circuit-Breaker Features and Accessories: Standard frame sizes, trip ratings, and number of poles.
1. Lugs: Mechanical style, suitable for number, size, trip ratings, and conductor materials.
 2. Application Listing: Appropriate for application; Type SWD for switching fluorescent lighting loads; Type HACR for heating, air-conditioning, and refrigerating equipment.
 3. Ground-Fault Protection: Integrally mounted relay and trip unit with adjustable pickup and time-delay settings, push-to-test feature, and ground-fault indicator.
 4. Shunt Trip: 120-V trip coil energized from separate circuit, set to trip at 75 percent of rated voltage.
 5. Multipole units enclosed in a single housing or factory-assembled to operate as a single unit.

2.7 ACCESSORY COMPONENTS AND FEATURES

- A. Furnish accessory set including tools and miscellaneous items required for overcurrent protective device test, inspection, maintenance, and operation.

PART 3 - EXECUTION

3.1 INSTALLATION

- A. Install panelboards and accessories according to NEMA PB 1.1.
- B. Mount top of trim 74 inches above finished floor, unless otherwise indicated.
- C. Mount plumb and rigid without distortion of box. Mount recessed panelboards with fronts uniformly flush with wall finish.
- D. Install overcurrent protective devices and controllers.
1. Set field-adjustable switches and circuit-breaker trip ranges.
- E. Install filler plates in unused spaces.
- F. Stub four 1-inch empty conduits from panelboard into accessible ceiling space or space designated to be ceiling space in the future.
- G. Arrange conductors in gutters and within panelboard into associated circuit groups and bundle and wrap with wire ties after completing load balancing.
- H. **ALL panel cans and covers with-in the same space shall be the same height.**

3.2 IDENTIFICATION

- A. Identify field-installed conductors, interconnecting wiring, and components; provide warning signs as specified in Division 26 Section "Electrical Identification."
- B. Create a directory to indicate installed circuit loads after balancing panelboard loads. Obtain approval before installing. Use a computer or typewriter to create directory; handwritten directories are not acceptable. Provide room being served identification for each circuit.
- C. Panelboard Nameplates: Label each panelboard with engraved metal or laminated-plastic nameplate mounted with corrosion-resistant screws.

3.3 CONNECTIONS

- A. Ground equipment according to Division 26 Section "Grounding and Bonding."
- B. Connect wiring according to Division 26 Section "Conductors and Cables."

3.4 FIELD QUALITY CONTROL

- A. Prepare for acceptance tests as follows:
 - 1. Test insulation resistance for each panelboard bus, component, connecting supply, feeder, and control circuit.
 - 2. Test continuity of each circuit.
- B. Testing Agency: Engage a qualified testing and inspecting agency to perform the following field tests and inspections and prepare test reports:
- C. Perform the following field tests and inspections and prepare test reports:
 - 1. Perform each electrical test and visual and mechanical inspection stated in NETA ATS, Section 7.5 for switches and Section 7.6 for molded-case circuit breakers. Certify compliance with test parameters.
 - 2. Correct malfunctioning units on-site, where possible, and retest to demonstrate compliance; otherwise, replace with new units and retest.
- D. Load Balancing: After Substantial Completion, but not more than 60 days after Final Acceptance, measure load balancing and make circuit changes.
 - 1. Measure as directed during period of normal system loading.
 - 2. Perform load-balancing circuit changes outside normal occupancy/working schedule of the facility and at time directed. Avoid disrupting critical 24-hour services such as fax machines and on-line data processing, computing, transmitting, and receiving equipment.
 - 3. After circuit changes, recheck loads during normal load period. Record all load readings before and after changes and submit test records.
 - 4. Tolerance: Difference exceeding 20 percent between phase loads, within a panelboard, is not acceptable. Rebalance and recheck as necessary to meet this minimum requirement.

- E. Infrared Scanning: After Substantial Completion, but not more than 60 days after Final Acceptance, perform an infrared scanning of each panelboard. Remove panel fronts so joints and connections are accessible to portable scanner.
 - 1. Follow-up Infrared Scanning: Perform an additional follow-up infrared scan of each panelboard 11 months after date of Substantial Completion.
 - 2. Instrument: Use an infrared scanning device designed to measure temperature or to detect significant deviations from normal values. Provide calibration record for device.
 - 3. Record of Infrared Scanning: Prepare a certified report that identifies panelboards checked and describes scanning results. Include notation of deficiencies detected, remedial action taken, and observations after remedial action.

3.5 CLEANING

- A. On completion of installation, inspect interior and exterior of panelboards. Remove paint splatters and other spots. Vacuum dirt and debris; do not use compressed air to assist in cleaning. Repair exposed surfaces to match original finish.

END OF SECTION 262416

SECTION 262726 - WIRING DEVICES



PART 1 - GENERAL

1.1 RELATED DOCUMENTS

- A. Drawings and general provisions of the Contract, including General and Supplementary Conditions and Division 1 Specification Sections, apply to this Section.

1.2 SUMMARY

- A. This Section includes the following:
 1. Single and duplex receptacles, ground-fault circuit interrupters, integral surge suppression units, and isolated-ground receptacles.
 2. Single- and double-pole snap switches and dimmer switches.
 3. Device wall plates.
 4. Pin and sleeve connectors and receptacles.
 5. Floor service outlets, poke-through assemblies, service poles, and multioutlet assemblies.

1.3 DEFINITIONS

- A. EMI: Electromagnetic interference.
- B. GFCI: Ground-fault circuit interrupter.
- C. PVC: Polyvinyl chloride.
- D. RFI: Radio-frequency interference.
- E. TVSS: Transient voltage surge suppressor.
- F. UTP: Unshielded twisted pair.

1.4 SUBMITTALS

- A. Product Data: For each type of product indicated.
- B. Shop Drawings: List of legends and description of materials and process used for premarking wall plates.
- C. Samples: One for each type of device and wall plate specified, in each color specified.
- D. Field quality-control test reports.

1.5 QUALITY ASSURANCE

- A. Source Limitations: Obtain each type of wiring device through one source from a single manufacturer.
- B. Electrical Components, Devices, and Accessories: Listed and labeled as defined in NFPA 70, Article 100, by a testing agency acceptable to authorities having jurisdiction, and marked for intended use.
- C. Comply with NFPA 70.

1.6 COORDINATION

- A. Receptacles for Owner-Furnished Equipment: Match plug configurations.
 - 1. Cord and Plug Sets: Match equipment requirements.

PART 2 - PRODUCTS

2.1 MANUFACTURERS

- A. Manufacturers: Subject to compliance with requirements, provide products by one of the following:
 - 1. Wiring Devices:
 - a. Hubbell Incorporated; Wiring Device-Kellems.
 - b. Leviton Mfg. Company Inc.
 - c. Pass & Seymour/Legrand; Wiring Devices Div.
 - 3. Multioutlet Assemblies:
 - a. Hubbell Incorporated; Wiring Device-Kellems.
 - b. Wiremold Company (The).

2.2 RECEPTACLES

- A. Straight-Blade-Type Receptacles: (Leviton 5362 or approved equal) Comply with NEMA WD 1, NEMA WD 6, DSCC W-C-596G, and UL 498.
- B. Straight-Blade and Locking Receptacles: Heavy-Duty grade.
- C. GFCI Receptacles: Straight blade, non-feed-through type, Heavy-Duty grade, with integral NEMA WD 6, Configuration 5-20R duplex receptacle; complying with UL 498 and UL 943. Design units for installation in a 2-3/4-inch- deep outlet box without an adapter. (Leviton Model # GFNT2 or approved equal)
- D. Isolated-Ground Receptacle: Straight blade, Heavy-Duty grade, duplex receptacle, with equipment grounding contacts connected only to the green grounding screw terminal of the

device and with inherent electrical isolation from mounting strap. (Leviton Model # 5362-IG or approved equal)

1. Devices: Listed and labeled as isolated-ground receptacles.
 2. Isolation Method: Integral to receptacle construction and not dependent on removable parts.
- E. TVSS Receptacles: Straight blade, NEMA WD 6, Configuration 5-20R, with integral TVSS in line to ground, line to neutral, and neutral to ground.
1. TVSS Components: Multiple metal-oxide varistors; with a nominal clamp level rating of 500 volts and minimum single transient pulse energy dissipation of 140 J line to neutral, and 70 J line to ground and neutral to ground.
 2. Active TVSS Indication: Visual only with light visible in face of device to indicate device is "active" or "no longer in service."
 3. Identification: Distinctive marking on face of device to denote TVSS-type unit.
- G. USB Receptacles: See site plan Symbol Schedule.
- H. Tamper Resistant: Leviton TBR20

2.3 CORD AND PLUG SETS

- A. Description: Match voltage and current ratings and number of conductors to requirements of equipment being connected.
1. Cord: Rubber-insulated, stranded-copper conductors, with Type SOW-A jacket; with green-insulated grounding conductor and equipment-rating ampacity plus a minimum of 30 percent.
 2. Plug: Nylon body and integral cable-clamping jaws. Match cord and receptacle type for connection.

2.4 SWITCHES (Leviton Models 1221-2,1222-2,1223-2 and 1224-2 or approved equal)

- A. Single- and Double-Pole Switches: Comply with DSCC W-C-896F and UL 20.
- B. Snap Switches: Heavy-Duty grade, quiet type.
- C. Combination Switch and Receptacle: Both devices in a single gang unit with plaster ears and removable tab connector that permit separate or common feed connection.
1. Switch: 20 A, 120/277-V ac.
 2. Receptacle: NEMA WD 6, Configuration 5-15R.
- D. Dimmer Switches: Modular, full-wave, solid-state units with integral, quiet on/off switches and audible frequency and EMI/RFI filters.
1. Control: Continuously adjustable toggle switch; with single-pole or three-way switching to suit connections.

2. LED Lamp Dimmers: Modular, 277 V, 60 Hz with continuously adjustable rotary knob, toggle switch, or slider; single pole with soft tap or other quiet switch; EMI/RFI filter to eliminate interference; and 5-inch wire connecting leads.
- 2.5 WALL PLATES (Hubbell, Leviton or approved equal)
- A. Single and combination types to match corresponding wiring devices.
 1. Plate-Securing Screws: Metal with head color to match plate finish.
 2. Material for Finished Spaces: Smooth, high-impact thermoplastic.
 3. Material for Unfinished Spaces: Galvanized steel.
 1. Material for Wet Locations: Cast aluminum with spring-loaded lift cover, and listed and labeled for use in "wet locations."
- 2.7 MULTIOUTLET ASSEMBLIES
- A. Components of Assemblies: Products from a single manufacturer designed for use as a complete, matching assembly of raceways and receptacles.
 - B. Raceway Material: Metal, with manufacturer's standard finish.
 - C. Wire: No. 12 AWG.
- 2.8 FINISHES
- A. Color:
 1. Wiring Devices Connected to Normal Power System: **As selected by Architect, unless otherwise indicated or required by NFPA 70.**
 2. TVSS Devices: Blue.
 3. Isolated-Ground Receptacles: As specified above, with orange triangle on face.

PART 3 - EXECUTION

3.1 INSTALLATION

- A. Install devices and assemblies level, plumb, and square with building lines.
- B. Install wall dimmers to achieve indicated rating after derating for ganging according to manufacturer's written instructions.
- C. Install unshared neutral conductors on line and load side of dimmers according to manufacturers' written instructions.
- D. Arrangement of Devices: Unless otherwise indicated, mount flush, with long dimension vertical, and with grounding terminal of receptacles on top. Group adjacent switches under single, multigang wall plates.

- E. Remove wall plates and protect devices and assemblies during painting.
- F. Adjust locations of floor service outlets and service poles to suit arrangement of partitions and furnishings.

3.2 IDENTIFICATION

- A. Comply with Division 26 Section "Electrical Identification."
 - 1. Receptacles: Identify panelboard and circuit number from which served. Use hot, stamped or engraved machine printing with black-filled lettering on face of plate, and durable wire markers or tags inside outlet boxes.

3.3 CONNECTIONS

- A. Ground equipment according to Division 26 Section "Grounding and Bonding."
- B. Connect wiring according to Division 26 Section "Conductors and Cables."
- C. Tighten electrical connectors and terminals according to manufacturer's published torque-tightening values. If manufacturer's torque values are not indicated, use those specified in UL 486A and UL 486B.

3.4 FIELD QUALITY CONTROL

- A. Perform the following field tests and inspections and prepare test reports:
 - 1. After installing wiring devices and after electrical circuitry has been energized, test for proper polarity, ground continuity, and compliance with requirements.
 - 2. Test GFCI operation with both local and remote fault simulations according to manufacturer's written instructions.
- B. Remove malfunctioning units, replace with new units, and retest as specified above.

END OF SECTION 262726

SECTION 262816 - ENCLOSED SWITCHES AND CIRCUIT BREAKERS

PART 1 - GENERAL

1.1 RELATED DOCUMENTS

- A. Drawings and general provisions of the Contract, including General and Supplementary Conditions and other Division 1 Specification Sections, apply to this Section.

1.2 SUMMARY

- A. This Section includes the following individually mounted, enclosed switches and circuit breakers:
 - 1. Fusible switches.
 - 2. Nonfusible switches.
 - 3. Molded-case circuit switches.
 - 4. Molded-case switches.
 - 5. Enclosures.

1.3 DEFINITIONS

- A. GD: General duty.
- B. GFCI: Ground-fault circuit interrupter.
- C. HD: Heavy duty.
- D. RMS: Root mean square.
- E. SPDT: Single pole, double throw.

1.4 SUBMITTALS

- A. Product Data: For each type of enclosed switch, circuit breaker, accessory, and component indicated. Include dimensioned elevations, sections, weights, and manufacturers' technical data on features, performance, electrical characteristics, ratings, and finishes.
 - 1. Enclosure types and details for types other than NEMA 250, Type 1.
 - 2. Current and voltage ratings.
 - 3. Short-circuit current rating.
 - 4. Features, characteristics, ratings, and factory settings of individual overcurrent protective devices and auxiliary components.
- B. Shop Drawings: Diagram power, signal, and control wiring.



- C. Operation and Maintenance Data: For enclosed switches and circuit breakers to include in emergency, operation, and maintenance manuals. In addition to items specified in Division 1 Section include the following:
 - 1. Manufacturer's written instructions for testing and adjusting enclosed switches and circuit breakers.
 - 2. Time-current curves, including selectable ranges for each type of circuit breaker.

1.5 QUALITY ASSURANCE

- A. Electrical Components, Devices, and Accessories: Listed and labeled as defined in NFPA 70, Article 100, by a testing agency acceptable to authorities having jurisdiction, and marked for intended use.
- B. Comply with NFPA 70.
- C. Product Selection for Restricted Space: Drawings indicate maximum dimensions for enclosed switches and circuit breakers, including clearances between enclosures, and adjacent surfaces and other items. Comply with indicated maximum dimensions.

1.6 PROJECT CONDITIONS

- A. Environmental Limitations: Rate equipment for continuous operation under the following conditions, unless otherwise indicated:
 - 1. Ambient Temperature: Not less than minus 22 deg F and not exceeding 104 deg F.
 - 2. Altitude: Not exceeding 6600 feet.

1.7 COORDINATION

- A. Coordinate layout and installation of switches, circuit breakers, and components with other construction, including conduit, piping, equipment, and adjacent surfaces. Maintain required workspace clearances and required clearances for equipment access doors and panels.

1.8 EXTRA MATERIALS

- A. Furnish extra materials described below that match products installed and that are packaged with protective covering for storage and identified with labels describing contents.
 - 1. Spares: For the following:
 - a. Fuses for Fusible Switches: 1% but not less than one of each type.
 - b. Fuses for Fused Power Circuit Devices: 1% but not less than one of each type.

PART 2 - PRODUCTS

2.1 MANUFACTURERS

- A. In other Part 2 articles where titles below introduce lists, the following requirements apply to product selection:
 - 1. Manufacturers: Subject to compliance with requirements, provide products by one of the manufacturers specified.

2.2 FUSIBLE AND NONFUSIBLE SWITCHES

- A. Manufacturers:
 - 1. General Electric Co.; Electrical Distribution & Control Division.
 - 2. Square D/Group Schneider.
 - 3. Eaton
- B. Fusible Switch, 1200 A and Smaller: NEMA KS 1, Type HD, with clips or bolt pads to accommodate specified fuses, lockable handle with capability to accept two padlocks, and interlocked with cover in closed position.
- C. Nonfusible Switch, 1200 A and Smaller: NEMA KS 1, Type HD, lockable handle with capability to accept two padlocks, and interlocked with cover in closed position.
- D. Accessories:
 - 1. Equipment Ground Kit: Internally mounted and labeled for copper and aluminum ground conductors.
 - 2. Neutral Kit: Internally mounted; insulated, capable of being grounded, and bonded; and labeled for copper and aluminum neutral conductors.
 - 3. Auxiliary Contact Kit: Auxiliary set of contacts arranged to open before switch blades open.

2.3 MOLDED-CASE CIRCUIT BREAKERS AND SWITCHES

- A. Manufacturers:
 - 1. General Electric Co.; Electrical Distribution & Control Division.
 - 2. Square D/Group Schneider.
 - 3. Eaton
- B. Molded-Case Circuit Breaker: NEMA AB 1, with interrupting capacity to meet available fault currents.
 - 1. Thermal-Magnetic Circuit Breakers: Inverse time-current element for low-level overloads and instantaneous magnetic trip element for short circuits. Adjustable magnetic trip setting for circuit-breaker frame sizes 250 A and larger.
 - 2. Adjustable Instantaneous-Trip Circuit Breakers: Magnetic trip element with front-mounted, field-adjustable trip setting.

3. Electronic Trip-Unit Circuit Breakers: RMS sensing; field-replaceable rating plug; with the following field-adjustable settings:
 - c. Instantaneous trip.
 - d. Long- and short-time pickup levels.
 - e. Long- and short-time time adjustments.
 - f. Ground-fault pickup level, time delay, and I^2t response.
 4. Current-Limiting Circuit Breakers: Frame sizes 400 A and smaller and let-through ratings less than NEMA FU 1, RK-5.
 5. Integrally Fused Circuit Breakers: Thermal-magnetic trip element with integral limiter-style fuse listed for use with circuit breaker and trip activation on fuse opening or on opening of fuse compartment door.
 6. GFCI Circuit Breakers: Single- and two-pole configurations with 5-mA trip sensitivity.
- C. Molded-Case Circuit-Breaker Features and Accessories:
1. Standard frame sizes, trip ratings, and number of poles.
 2. Lugs: Mechanical style suitable for number, size, trip ratings, and conductor material.
 3. Application Listing: Type SWD for switching fluorescent lighting loads; Type HACR for heating, air-conditioning, and refrigerating equipment.
 4. Ground-Fault Protection: Integrally mounted relay and trip unit with adjustable pickup and time-delay settings, push-to-test feature, and ground-fault indicator.
 5. Shunt Trip: 120-V trip coil energized from separate circuit, set to trip at 55 percent of rated voltage.
 6. Undervoltage Trip: Set to operate at 35 to 75 percent of rated voltage with field-adjustable 0.1- to 0.6-second time delay.
 7. Auxiliary Switch: Two SPDT switches with "a" and "b" contacts; "a" contacts mimic circuit-breaker contacts, "b" contacts operate in reverse of circuit-breaker contacts.
 5. Key Interlock Kit: Externally mounted to prohibit circuit-breaker operation; key shall be removable only when circuit breaker is in off position.
 6. Zone-Selective Interlocking: Integral with electronic trip unit; for interlocking ground-fault protection function.
- D. Molded-Case Switches: Molded-case circuit breaker with fixed, high-set instantaneous trip only, and short-circuit withstand rating equal to equivalent breaker frame size interrupting rating.
- E. Molded-Case Switch Accessories:
1. Lugs: Mechanical style suitable for number, size, trip ratings, and material of conductors.
 2. Application Listing: Type HACR for heating, air-conditioning, and refrigerating equipment.
 3. Shunt Trip: 120-V trip coil energized from separate circuit, set to trip at 55 percent of rated voltage. Provide "dummy" trip unit where required for proper operation.
 4. Undervoltage Trip: Set to operate at 35 to 75 percent of rated voltage with field-adjustable 0.1- to 0.6-second time delay. Provide "dummy" trip unit where required for proper operation.
 5. Auxiliary Switch: Two SPDT switches with "a" and "b" contacts; "a" contacts mimic circuit-breaker contacts, "b" contacts operate in reverse of circuit-breaker contacts.

6. Key Interlock Kit: Externally mounted to prohibit operation; key shall be removable only when switch is in off position.

2.5 ENCLOSURES

- A. NEMA AB 1 and NEMA KS 1 to meet environmental conditions of installed location.
 1. Outdoor Locations: NEMA 250, Type 3R.
 2. Other Wet or Damp Indoor Locations: NEMA 250, Type 4.

PART 3 – EXECUTION

3.1 EXAMINATION

- A. Examine elements and surfaces to receive enclosed switches and circuit breakers for compliance with installation tolerances and other conditions affecting performance.
- B. Proceed with installation only after unsatisfactory conditions have been corrected.

3.2 CONCRETE BASES

- A. Coordinate size and location of concrete bases. Verify structural requirements with structural engineer.
- B. Concrete base is specified in Division 26 Section "Basic Electrical Materials and Methods", and concrete materials and installation requirements are specified in Division 3.

3.3 INSTALLATION

- A. Comply with applicable portions of NECA 1, NEMA PB 1.1, and NEMA PB 2.1 for installation of enclosed switches and circuit breakers.
- B. Mount individual wall-mounting switches and circuit breakers with tops at uniform height, unless otherwise indicated. Anchor floor-mounting switches to concrete base.
- C. Comply with mounting and anchoring requirements specified in Division 26 Section "Seismic Controls for Electrical Work".
- D. Temporary Lifting Provisions: Remove temporary lifting eyes, channels, and brackets and temporary blocking of moving parts from enclosures and components.

3.4 IDENTIFICATION

- A. Identify field-installed conductors, interconnecting wiring, and components; provide warning signs as specified in Division 26 Section "Electrical Identification".

- B. Enclosure Nameplates: Label each enclosure with engraved metal or laminated-plastic nameplate as specified in Division 26 Section "Electrical Identification",

3.5 FIELD QUALITY CONTROL

- A. Manufacturer's Field Service: Engage a factory-authorized service representative to inspect field-assembled components and equipment installation, including connections. Report results in writing.
 - 1. Inspect mechanical and electrical connections.
 - 2. Verify switch and relay type and labeling verification.
 - 3. Verify rating of installed fuses.
- B. Perform the following field tests and inspections and prepare test reports:
 - 1. Perform each electrical test and visual and mechanical inspection stated in NETA ATS, Section 7.5 for switches and Section 7.6 for molded-case circuit breakers. Certify compliance with test parameters.
 - 2. Correct malfunctioning units on-site, where possible, and retest to demonstrate compliance; otherwise, replace with new units and retest.
 - 3. Infrared Scanning:
 - a. Initial Infrared Scanning: After Substantial Completion, but not more than 60 days after Final Acceptance, perform an infrared scan of each enclosed switch and circuit breaker. Open or remove doors or panels so connections are accessible to portable scanner.
 - b. Follow-Up Infrared Scanning: Perform an additional follow-up infrared scan of each unit 11 months after date of Substantial Completion.
 - c. Instruments, Equipment and Reports:
 - 1) Use an infrared scanning device designed to measure temperature or to detect significant deviations from normal values. Provide calibration record for device.
 - 2) Prepare a certified report that identifies enclosed switches and circuit breakers included and describes scanning results. Include notation of deficiencies detected, remedial action taken, and observations after remedial action.

3.6 ADJUSTING

- A. Set field-adjustable switches and circuit-breaker trip ranges.

3.7 CLEANING

- A. On completion of installation, vacuum dirt and debris from interiors; do not use compressed air to assist in cleaning.
- B. Inspect exposed surfaces and repair damaged finishes.

END OF SECTION 262816

SECTION 264313 - TRANSIENT VOLTAGE SUPPRESSION

PART 1 - GENERAL



1.1 RELATED DOCUMENTS

- A. Drawings and general provisions of the Contract, including General and Supplementary Conditions and Division 1 Specification Sections, apply to this Section.

1.2 SUMMARY

- A. This Section includes transient voltage surge suppressors for low-voltage power, control, and communication equipment.
- B. Related Sections include the following:
 - 1. Division 26 Section "Panelboards" for factory-installed transient voltage surge suppressors.

1.3 SUBMITTALS

- A. Product Data: For each type of product indicated. Include rated capacities; shipping, installed, and operating weights; furnished specialties; and accessories.
- B. Maintenance Data: For transient voltage suppression devices to include in maintenance manuals specified in Division 1.
- C. Warranties: Special warranties specified in this Section.

1.4 QUALITY ASSURANCE

- A. Source Limitations: Obtain suppression devices and accessories through one source from a single manufacturer.
- B. Electrical Components, Devices, and Accessories: Listed and labeled as defined in NFPA 70, Article 100, by a testing agency acceptable to authorities having jurisdiction, and marked for intended use.

1.5 PROJECT CONDITIONS

- A. Existing Utilities: Do not interrupt utilities serving facilities occupied by Owner or others unless permitted under the following conditions and then only after arranging to provide temporary utility services according to requirements indicated:
 - 1. Notify Architect not less than two weeks in advance of proposed utility interruptions.
 - 2. Do not proceed with utility interruptions without Architect's written permission.

- B. Service Conditions: Rate surge protective devices for continuous operation under the following conditions, unless otherwise indicated:
 - 1. Maximum Continuous Operating Voltage: Not less than 115 percent of nominal system operating voltage.
 - 2. Operating Temperature: 30 to 120 deg F.
 - 3. Humidity: 0 to 85 percent, noncondensing.
 - 4. Altitude: Less than 20,000 feet above sea level.

1.6 COORDINATION

- A. Coordinate location of field-mounted surge suppressors to allow adequate clearances for maintenance. Integrally mount as direct buss connected to panelboards.

1.7 WARRANTY

- A. General Warranty: Special warranties specified in this Article shall not deprive Owner of other rights Owner may have under other provisions of the Contract Documents and shall be in addition to, and run concurrent with, other warranties made by Contractor under requirements of the Contract Documents.

1.8 EXTRA MATERIALS

- A. Furnish extra materials described below that match products installed and that are packaged with protective covering for storage and identified with labels describing contents.
 - 1. Replaceable Protection Modules: One of each size and type installed.

PART 2 - PRODUCTS

2.1 SERVICE ENTRANCE SUPPRESSORS:

- A. Surge Protective Device Description: Modular design with field-replaceable modules and the following features and accessories:
 - 1. Fabrication using bolted compression lugs for internal wiring.
 - 2. Integral disconnect switch.
 - 3. Redundant suppression circuits.
 - 4. Redundant replaceable modules.
 - 5. Arrangement with wire connections to phase buses, neutral bus, and ground bus.
 - 6. Red and green LED indicator lights for power and protection status.
 - 7. Audible alarm, with silencing switch, to indicate when protection has failed.
 - 8. One set of dry contacts rated at 5 A and 250-V ac, for remote monitoring of protection status. Coordinate with building power monitoring and control system.
 - 9. Surge-event operations counter.

- B. Peak Single-Impulse Surge Current Rating: 400 kA per phase or as per plans
- C. Connection Means: Permanently wired directly to buss with integral disconnect means.
- D. Protection modes clamping voltage for grounded wye circuits with voltages of 480Y/277 and 208Y/120; 3-phase, 4-wire circuits, shall be as follows:
 - 1. Line to Neutral: 800 V for 480Y/277 and 400 V for 208Y/120.
 - 2. Line to Ground: 800 V for 480Y/277 and 400 V for 208Y/120.
 - 3. Neutral to Ground: 800 V for 480Y/277 and 400 V for 208Y/120.

2.2 CONTROL AND DATA TERMINALS

- A. Protectors for copper data and telephone conductors entering the building from the outside shall be as recommended by the manufacturer for the type of line being protected.

2.3 ENCLOSURES

- A. NEMA 250, with type matching the enclosure of panel or device being protected.

PART 3 - EXECUTION

3.1 INSTALLATION OF SURGE PROTECTIVE DEVICES

- A. Install devices at service entrance on load side, with ground lead bonded to service entrance ground.
- B. Install devices for panelboard and auxiliary panels with conductors between suppressor and points of attachment as short and straight as possible. Do not exceed manufacturer's recommended lead length. Do not bond neutral and ground.
 - 1. Connect directly to buss at panelboards.

3.2 CONNECTIONS

- A. Tighten electrical connectors and terminals according to manufacturer's published torque-tightening values

3.3 FIELD QUALITY CONTROL

- A. Testing: Perform the following field quality-control testing:
 - 1. After installing surge protective devices, but before electrical circuitry has been energized, test for compliance with requirements.
 - 2. Complete startup checks according to manufacturer's written instructions.
 - 3. Perform each visual and mechanical inspection and electrical test stated in NETA ATS, Section 7.19. Certify compliance with test parameters.

- B. Repair or replace malfunctioning units. Retest after repairs or replacements are made.
- C. Manufacturer's Field Service: Engage a factory-authorized service representative to inspect field-assembled components and equipment installation, including piping and electrical connections. Report results in writing.
 - 1. Verify that electrical wiring installation complies with manufacturer's installation requirements.

3.4 DEMONSTRATION

- A. Engage a factory-authorized service representative to train Owner's maintenance personnel to adjust, operate, and maintain surge protective devices.
 - 1. Train Owner's maintenance personnel on procedures and schedules for maintaining suppressors.
 - 2. Review data in maintenance manuals. Refer to Specification Section "Contract Closeout".
 - 3. Review data in maintenance manuals. Refer to Specification Section "Operation and Maintenance Data".
 - 4. Schedule training with Owner, through Architect, with at least seven days' advance notice. Include one hour of training for owners team.

END OF SECTION 264313

SECTION 265119 - LED INTERIOR LIGHTING

PART 1 - GENERAL

1.1 SUMMARY

A. Section Includes:

1. Interior solid-state luminaires that use LED technology.
2. Lighting fixture supports.

B. Related Requirements:

1. Section 260923 "Lighting Control Devices" for automatic control of lighting, including time switches, photoelectric relays, occupancy sensors, and multipole lighting relays and contactors.

1.2 DEFINITIONS

- A. CCT: Correlated color temperature.
- B. CRI: Color Rendering Index.
- C. Fixture: See "Luminaire."
- D. IP: International Protection or Ingress Protection Rating.
- E. LED: Light-emitting diode.
- F. Lumen: Measured output of lamp and luminaire, or both.
- G. Luminaire: Complete lighting unit, including lamp, reflector, and housing.

1.3 ACTION SUBMITTALS

A. Product Data: For each type of product, arranged by designation.

B. Shop Drawings: For nonstandard or custom luminaires.

1. Include plans, elevations, sections, and mounting and attachment details.
2. Include details of luminaire assemblies. Indicate dimensions, weights, loads, required clearances, method of field assembly, components, and location and size of each field connection.
3. Include diagrams for power, signal, and control wiring.

C. Product Schedule: For luminaires and lamps. (**See Plans.**)



1.4 INFORMATIONAL SUBMITTALS

- A. Coordination Drawings: Reflected ceiling plan(s) and other details, drawn to scale and coordinated with each other, using input from installers of the items involved:
- B. Seismic Qualification Certificates: For luminaires, accessories, and components, from manufacturer.
- C. Product Certificates: For each type of luminaire.
- D. Sample warranty.

1.5 CLOSEOUT SUBMITTALS

- A. Operation and maintenance data.

1.6 WARRANTY

- A. Warranty: Manufacturer and Installer agree to repair or replace components of luminaires that fail in materials or workmanship within specified warranty period.
- B. Warranty Period for all LED Fixtures: **Five (5) years** from date of Substantial Completion.

1.7 EXTRA MATERIALS

- A. Furnish extra materials described below that match products installed and that are packaged with protective covering for storage and identified with labels describing contents.
 - 1. Drivers: 1 for every 100 of each type and rating installed. Furnish at least one of each type.

PART 2 - PRODUCTS

2.1 LUMINAIRE REQUIREMENTS

- A. Electrical Components, Devices, and Accessories: Listed and labeled as defined in NFPA 70, by a qualified testing agency, and marked for intended location and application.
- B. NRTL Compliance: Luminaires for hazardous locations shall be listed and labeled for indicated class and division of hazard by an NRTL.
- C. FM Global Compliance: Luminaires for hazardous locations shall be listed and labeled for indicated class and division of hazard by FM Global.
- D. Recessed Fixtures: Comply with NEMA LE 4.
- E. CRI of **minimum 80**. CCT at 4000K (**See Fixture Schedule**)

- F. Rated lamp life of **50,000** hours minimum or equal to specified fixtures which is more.
- G. Lamps dimmable from 100 percent to 0 percent of maximum light output.
- H. Internal driver.
- I. Nominal Operating Voltage: **120V**.
 - 1. Lens Thickness: At least 0.125 inch (3.175 mm) minimum unless otherwise indicated.

2.2 MATERIALS

- A. Metal Parts:
 - 1. Free of burrs and sharp corners and edges.
 - 2. Sheet metal components shall be steel unless otherwise indicated.
 - 3. Form and support to prevent warping and sagging
- B. Doors, Frames, and Other Internal Access: Smooth operating, free of light leakage under operating conditions, and designed to permit relamping without use of tools. Designed to prevent doors, frames, lenses, diffusers, and other components from falling accidentally during relamping and when secured in operating position.
- C. Diffusers, and Globes:
 - 1. Acrylic: One hundred percent virgin acrylic plastic, with high resistance to yellowing and other changes due to aging, exposure to heat, and UV radiation.
 - 2. Glass: Annealed crystal glass unless otherwise indicated.
 - 3. Lens Thickness: At least 0.125 inch (3.175 mm) minimum unless otherwise indicated.

2.3 METAL FINISHES

- A. Variations in finishes are unacceptable in the same piece. Variations in finishes of adjoining components are acceptable if they are within the range of approved Samples and if they can be and are assembled or installed to minimize contrast.

2.4 LUMINAIRE SUPPORT COMPONENTS

- A. Comply with requirements in Section 26 “Basic Electrical Materials and Methods” for channel and angle iron supports and nonmetallic channel and angle supports.
- B. Single-Stem Hangers: 1/2-inch (13-mm) steel tubing with swivel ball fittings and ceiling canopy. Finish same as luminaire.
- C. Wires: ASTM A 641/A 641 M, Class 3, soft temper, zinc-coated steel.
- D. Rod Hangers: 3/16-inch (5-mm) minimum diameter, cadmium-plated, threaded steel rod.

- E. Hook Hangers: Integrated assembly matched to luminaire, line voltage, and equipment with threaded attachment, cord, and locking-type plug.

PART 3 - EXECUTION

3.1 INSTALLATION

- A. Comply with NECA 1.
- B. Install luminaires level, plumb, and square with ceilings and walls unless otherwise indicated.
- C. Install lamps in each luminaire.
- D. Supports: Sized and rated for luminaire weight.
- E. Flush-Mounted Luminaire Support: Secured to outlet box.
- F. Suspended Luminaire Support:
 - 1. Pendants and Rods: Where longer than 48 inches (1200 mm), brace to limit swinging.
 - 2. Stem-Mounted, Single-Unit Luminaires: Suspend with four-stem hangers. Support with approved outlet box and accessories that hold stem and provide damping of luminaire oscillations. Support outlet box vertically to building structure using approved devices.
 - 3. Continuous Rows of Luminaires: Use tubing or stem for wiring at one point and **rod** for suspension for each unit length of luminaire chassis, including one at each end.
 - 4. Do not use ceiling grid as support for pendant luminaires. Connect support wires or rods to building structure.
- G. Ceiling-Grid-Mounted Luminaires:
 - 1. Secure to any required outlet box.
 - 2. Secure luminaire using approved fasteners in a minimum of four locations, spaced near corners of luminaire.
- H. Identify system components, wiring, cabling, and terminals. Comply with requirements for identification specified in Section 260553 "Electrical Identification".

3.2 FIELD QUALITY CONTROL

- A. Perform the following tests and inspections:
 - 1. Operational Test: After installing luminaires, switches, and accessories, and after electrical circuitry has been energized, test units to confirm proper operation.
 - 2. Test for Emergency Lighting: Interrupt power supply to demonstrate proper operation. Verify transfer from normal power to battery power and retransfer to normal.
- B. Luminaire will be considered defective if it does not pass operation tests and inspections.
- C. Prepare test and inspection reports.

END OF SECTION 265119

ATTACHMENT B
TO FOLLOW IMMEDIATELY

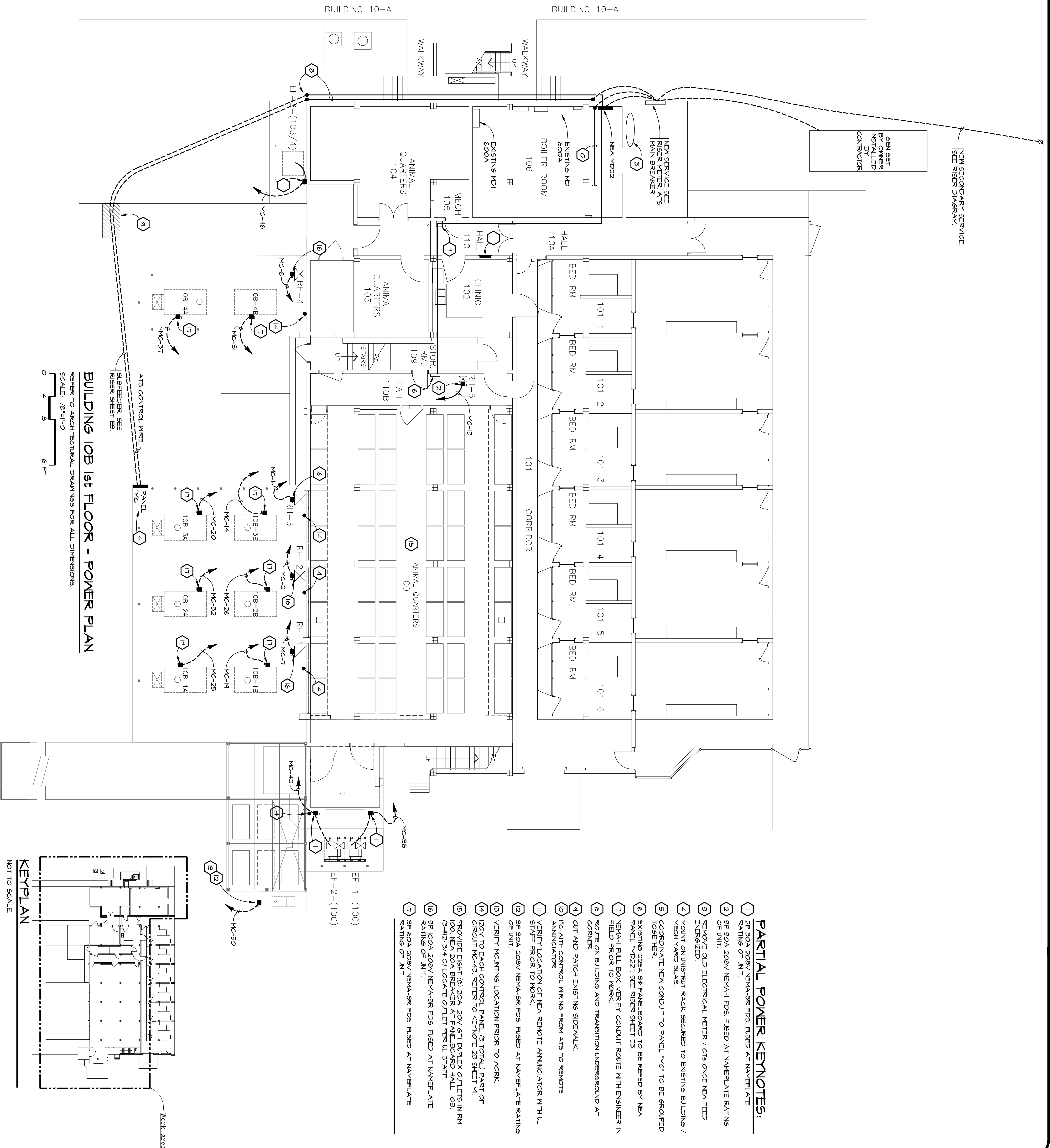

PARTIAL POWER KEYNOTES:

- ① 3P 30A 208V NEMA-3R FDS, FUSED AT NAMEPLATE RATING OF UNIT.
- ② 3P 30A 208V NEMA-1 FDS, FUSED AT NAMEPLATE RATING OF UNIT.
- ③ REMOVE OLD ELECTRICAL METER / CT'S ONCE NEW FEED ENERGIZED.
- ④ MOUNT ON UNSTRUCT RACK SECURED TO EXISTING BUILDING / MECH FLOOR SLAB.
- ⑤ COORDINATE NEW CONDUIT TO PANEL. "MC" TO BE GROUPED TOGETHER.
- ⑥ EXISTING 225A 3P PANELBOARD TO BE REFEED BY NEW PANEL. "WD22". SEE RISER SHEET E3.
- ⑦ NEW-1 PULL BOX. VERIFY CONDUIT ROUTE WITH ENGINEER IN FIELD PRIOR TO WORK.
- ⑧ ROUTE ON BUILDING AND TRANSITION UNDERGROUND AT CORNER.
- ⑨ CUT AND PATCH EXISTING SIDEWALK.
- ⑩ ITC WITH CONTROL WIRING FROM ATS TO REMOTE ANNUNCIATOR.
- ⑪ VERIFY LOCATION OF NEW REMOTE ANNUNCIATOR WITH UL STAFF PRIOR TO WORK.
- ⑫ 3P 30A 208V NEMA-3R FDS, FUSED AT NAMEPLATE RATING OF UNIT.
- ⑬ VERIFY MOUNTING LOCATION PRIOR TO WORK.
- ⑭ 120V TO EACH CONTROL PANEL (5 TOTAL PART OF CIRCUIT MC-43. REFER TO KEYNOTE 23 SHEET M1.
- ⑮ PROVIDE EIGHT (8) 20A 120V GFI DUPLEX OUTLETS IN RM 100. NEW 20A BREAKER AT PANELBOARD HALL 110B. (3-#12 51/4"Ø) LOCATE OUTLET PER UL STAFF.
- ⑯ 3P 100A 208V NEMA-3R FDS, FUSED AT NAMEPLATE RATING OF UNIT.
- ⑰ 3P 60A 208V NEMA-3R FDS, FUSED AT NAMEPLATE RATING OF UNIT.

BUILDING 10B 1st FLOOR - POWER PLAN

REFER TO ARCHITECTURAL DRAWINGS FOR ALL DIMENSIONS.

SCALE: 1/8"=1'-0"
0 4 8 16 FT

KEYPLAN

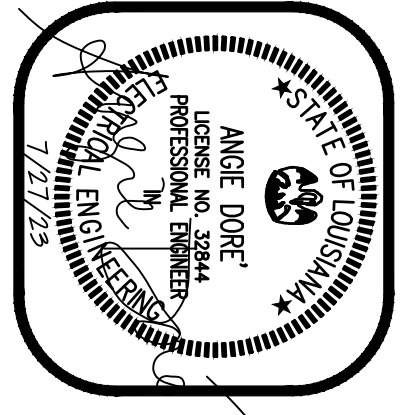
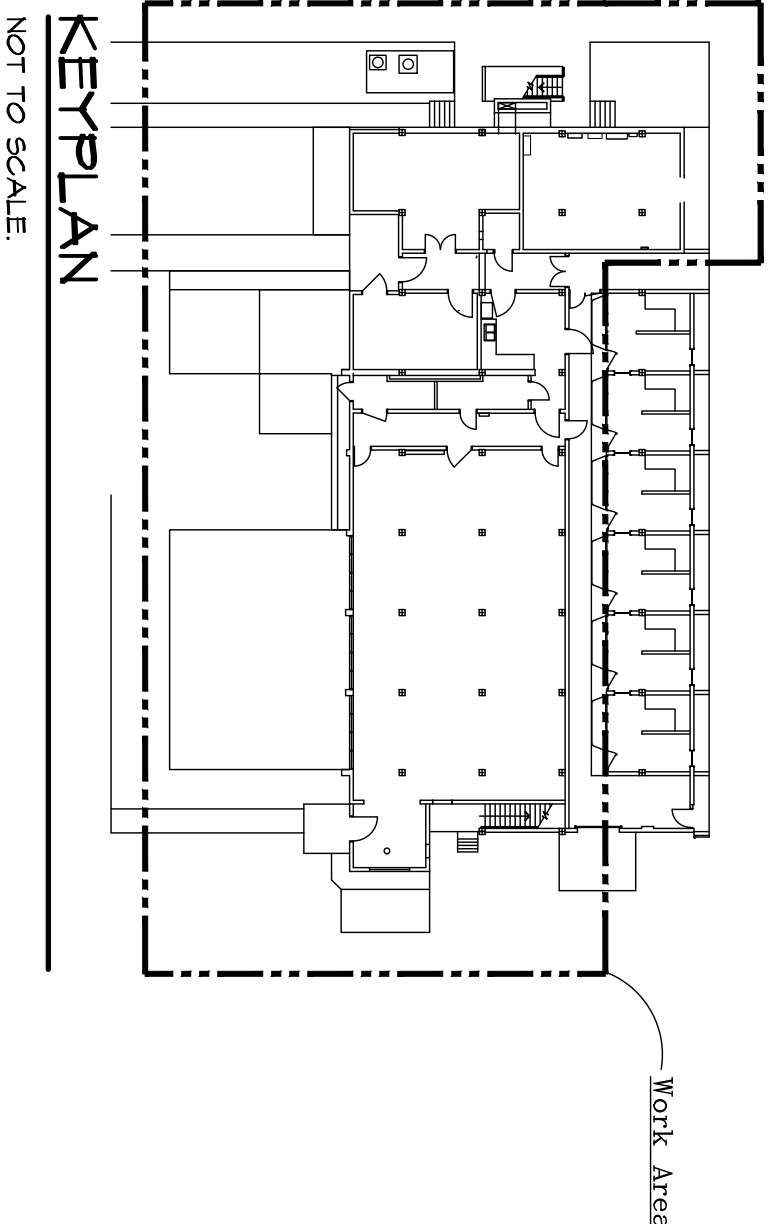

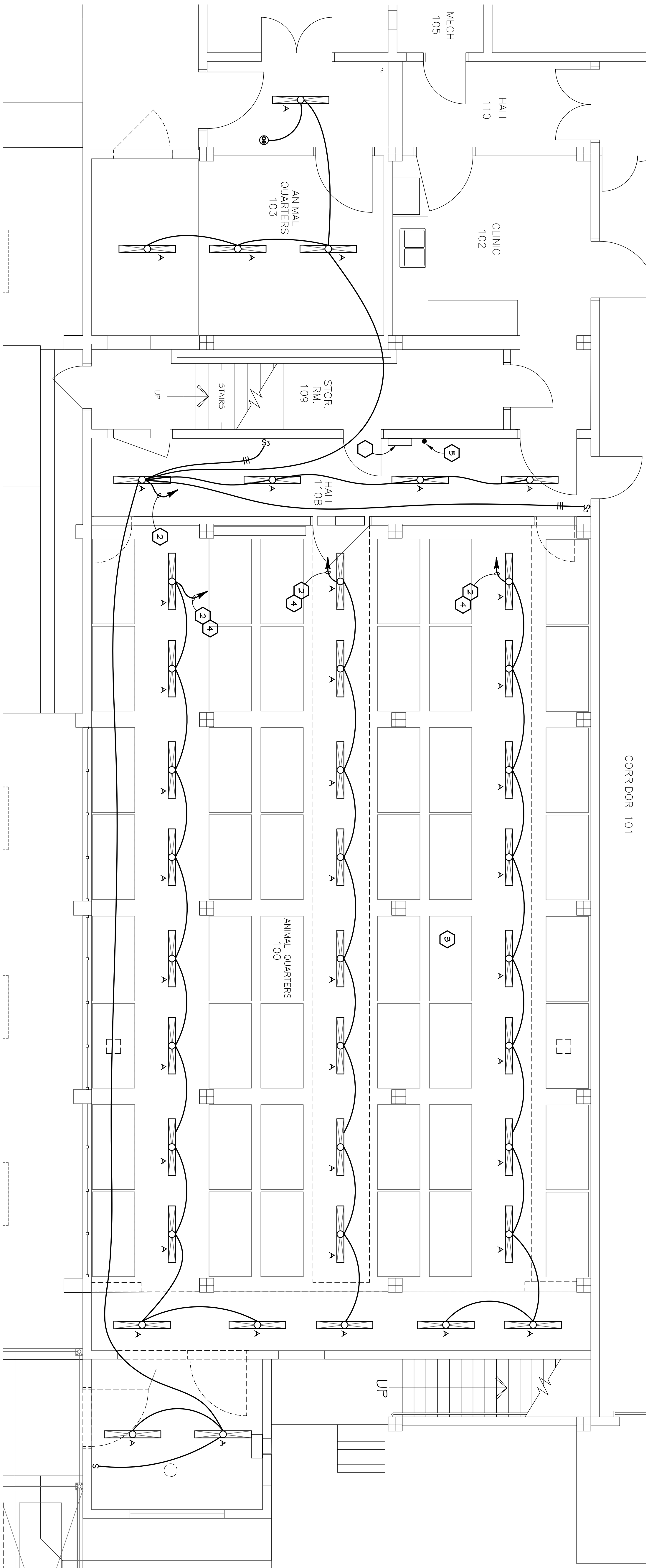

LIGHTING FIXTURE SCHEDULE

FIXTURE TYPE	MANUFACTURER	CATALOG NUMBER	LAMPS	DESCRIPTION	REMARKS
A	LITHONIA	DMX 2 54T9HQ 120 GE80/05 ALF	2- 54W T9HQ	SEALED STRIP	

- NOTES:
 1. ALL FIXTURES ACCESSORIES NEEDED FOR PROPER INSTALLATION SHALL BE PROVIDED AND INSTALLED BY ELECTRICAL CONTRACTOR.
 2. CONTRACTOR TO PROVIDE AND INSTALL ANY AND ALL LOW VOLTAGE CONTROLS REQUIRED FOR DIMMING AND / OR OCCUPANCY SENSORS.

LIGHTING KEYNOTES:

- 1 EXISTING PANELBOARD.
- 2 PROVIDE NM 20A 1P 120V CIRCUIT TO EXISTING PANELBOARD RM 110B (3-#12, 1/2") PROVIDE NEW BREAKER IN SAME CONNECTIONS.
- 3 ALL NEW CONDUIT AND WIRING TO BE EMT WITH COMPRESSION CONNECTIONS.
- 4 CONTROLLED BY LIGHTING CONTACTOR AND NEW INTERMATIC TIMER MODEL T101 OR APPROVED EQUAL. TIMER TO CONTROL CONTACTOR ENERGIZING THREE (3) LIGHT CIRCUITS AT RM 100.
- 5 LOCATE CONTACTOR TIMER ADJACENT PANEL.

VERIFY PLACEMENT OF ALL LIGHTING FIXTURES AND SWITCHES WITH UL STAFF PRIOR TO ROUGH-IN.

BUILDING 10-B 1st FLOOR POWER & LIGHTING PLAN

REFER TO ARCHITECTURAL DRAWINGS FOR ALL DIMENSIONS.

SCALE: 1/4"=1'-0"
 0 2 4 8 FT

KEYPLAN

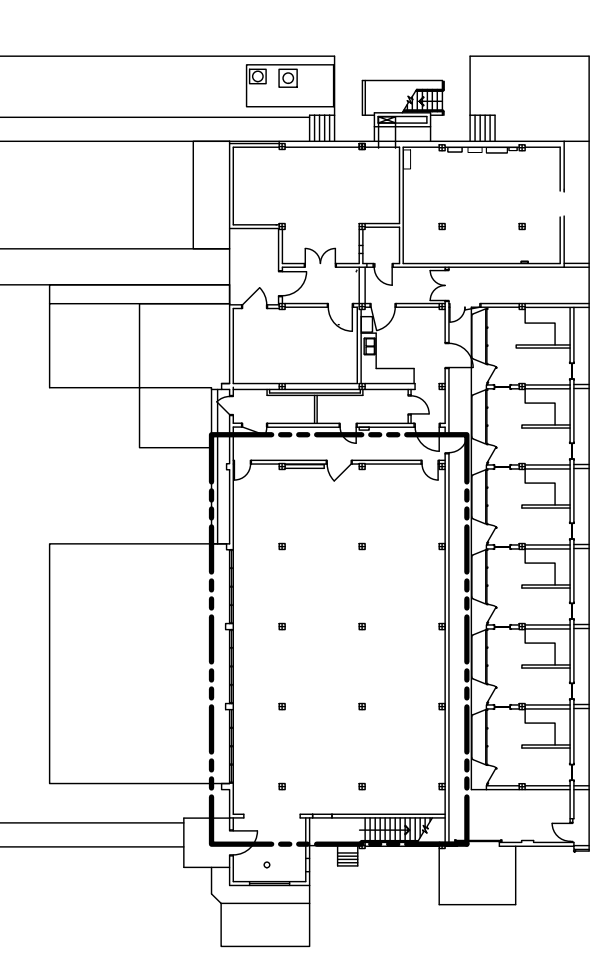

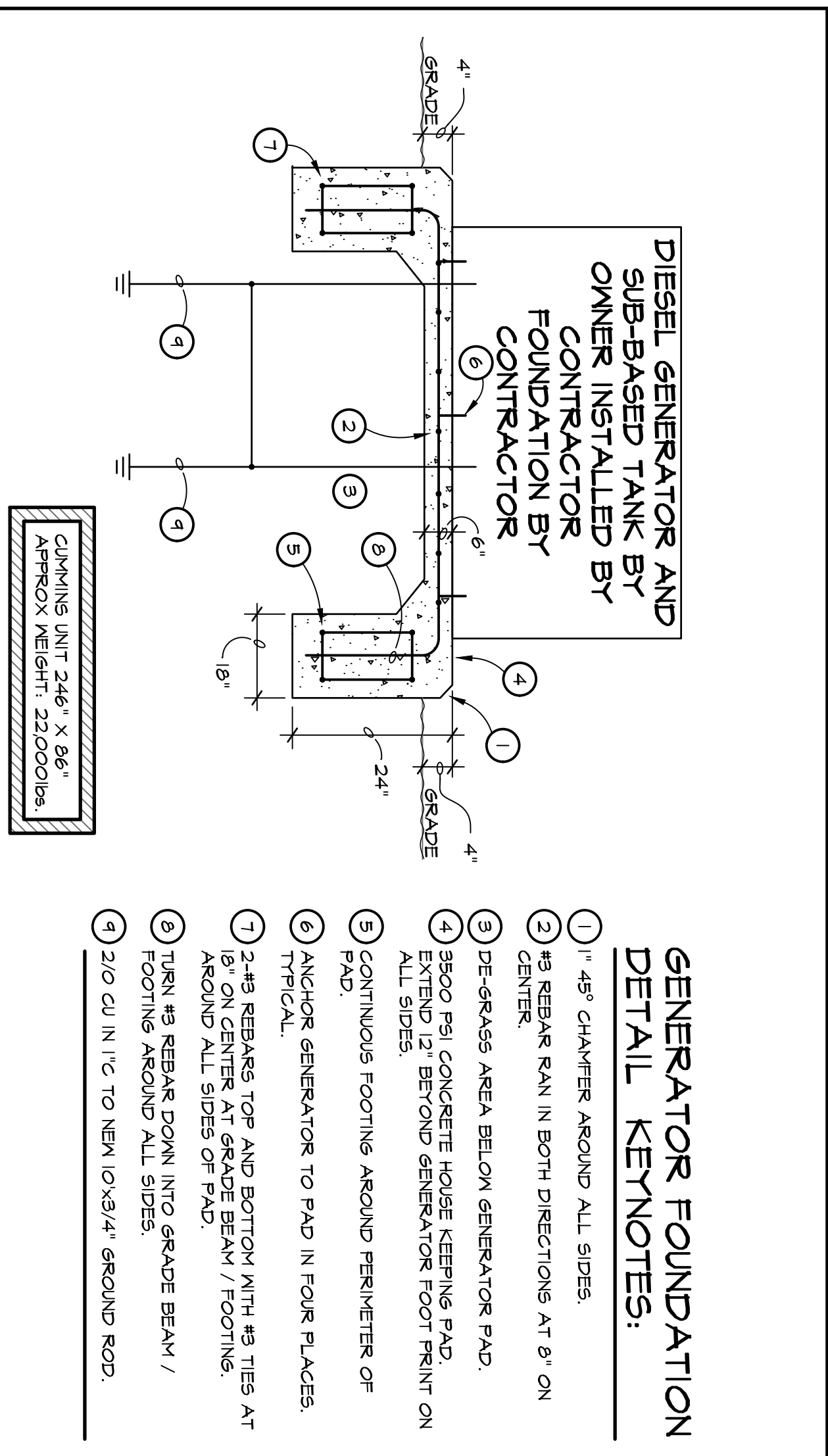

4 GENERATOR FOUNDATION DETAIL NOT TO SCALE

COORDINATE ANY AND ALL REQUIRED POWER OUTAGES WITH UL STAFF WITH MINIMUM SEVEN (7) DAY NOTICE. UL APPROVED REQUIRED FOR ALL OUTAGES.

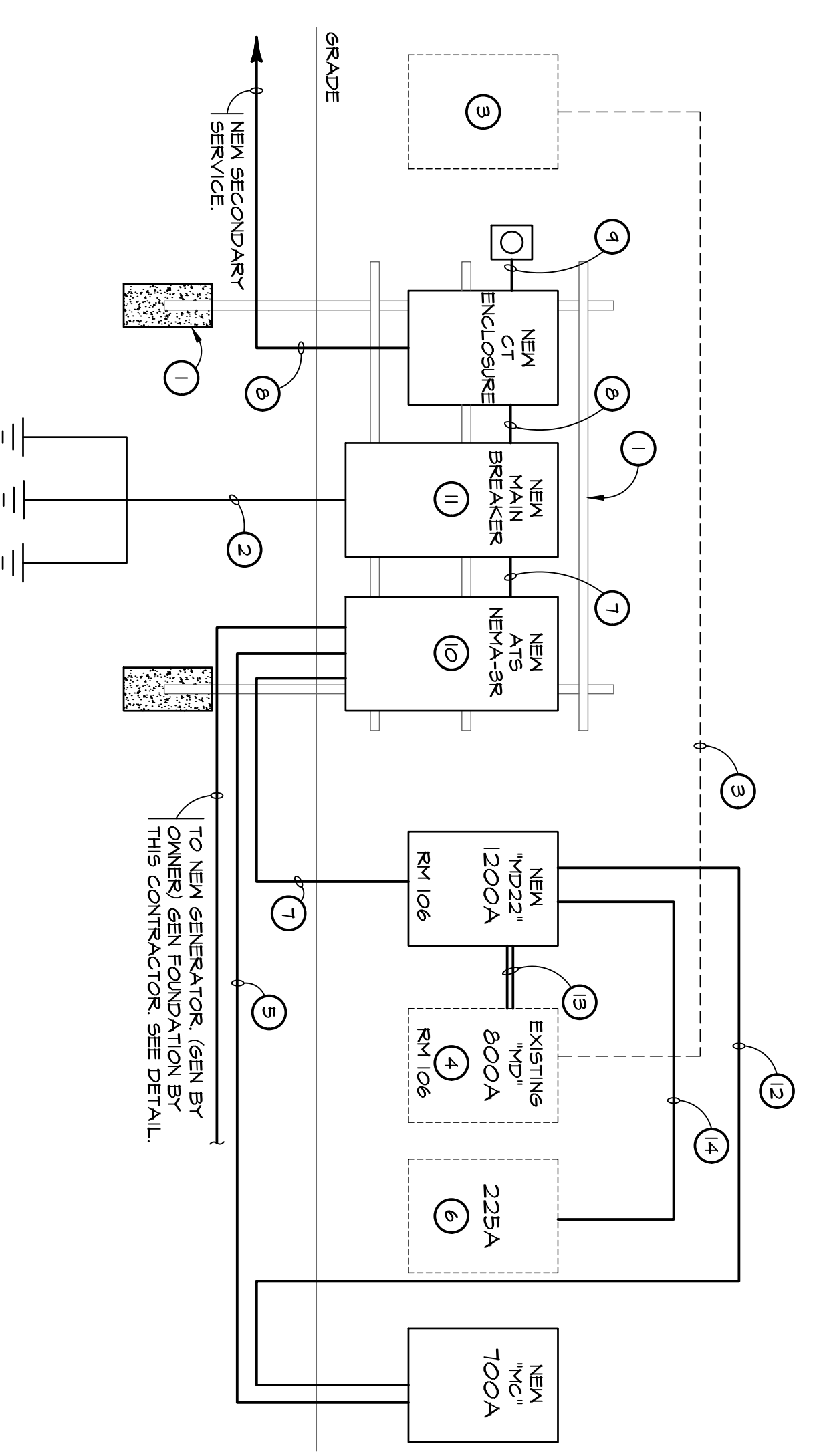

- ELECTRICAL RISER NOTES:**
1. CONTRACTOR SHALL CONTACT UTILITY COMPANY PRIOR TO ANY WORK AND ANY CHANGES FOR SERVICES SHOWN, SAME SHALL BE IN BID.
 2. CONTRACTOR TO USE MYERS HUB CONNECTORS AT ALL EXTERIOR PANELBOARDS (DISCONNECTS, ETC) PENETRATIONS (INCLUDING SIDE PENETRATIONS).
 3. ALL CONDUCTORS SHALL BE COPPER.
 4. ALL WORK SHALL BE IN COMPLIANCE WITH NFPA TO NATIONAL ELECTRICAL CODE 2020 VERSION AND INSTALLATION DONE BY QUALIFIED LICENSED ELECTRICIAN.
 5. CONTRACTOR TO REFER TO DIV 26 SPECIFICATIONS FOR REQUIREMENTS ON TESTING, IR SCANS AND LOAD BALANCING REQUIREMENTS.
 6. CONTRACTOR TO PROVIDE PERMANENT MARKING OF PHASE ROTATION AT MAIN SERVICE INTERIOR PANEL.

ELECTRICAL RISER KEYNOTES:

- 1 NEW 2" GALVANIZED PIPE RACK SET IN 24" CONCRETE FOUNDATIONS.
- 2 2/0 TO THREE (3) 10x3/4" GROUND RODS.
- 3 EXISTING WETTER AND FEED TO EXISTING "ND" TO BE REMOVED ONCE NEW SERVICE ENERGIZED.
- 4 ISOLATE GROUND AND NEUTRAL.
- 5 1" C WITH CONTROL WIRING TO SHUNT TRIP BREAKER UPON TRANSFER TO GENERATOR POWER AT SIGNAL TO SHUNT MAIN BREAKER AT PANEL "1C".
- 6 EXISTING 225A 90 PANELBOARD IN HALL 110B.
- 7 3 SETS OF 4" C WITH 4-600, 1-9/16" IN EACH.
- 8 3 SETS OF 4" C WITH 4-600, 1-9/16" IN EACH.
- 9 3 SETS OF 4" C WITH 4-600, 1-1/10" IN EACH.
- 10 1" C WITH CONTROL WIRING.
- 11 1200 AMP 208V 3P AUTOMATIC TRANSFER SWITCH NEMA-3R (CUMMINS, ASCO OR APPROVED EQUAL).
- 12 2 SETS OF 3" C WITH 4-500, 1-1/16" IN EACH.
- 13 2 SETS OF 4" C WITH 4-600, 1-1/10" IN EACH.
- 14 4-4/0, 1-1/4" 2 1/2" C.

4 ELECTRICAL RISER DIAGRAM NOT TO SCALE

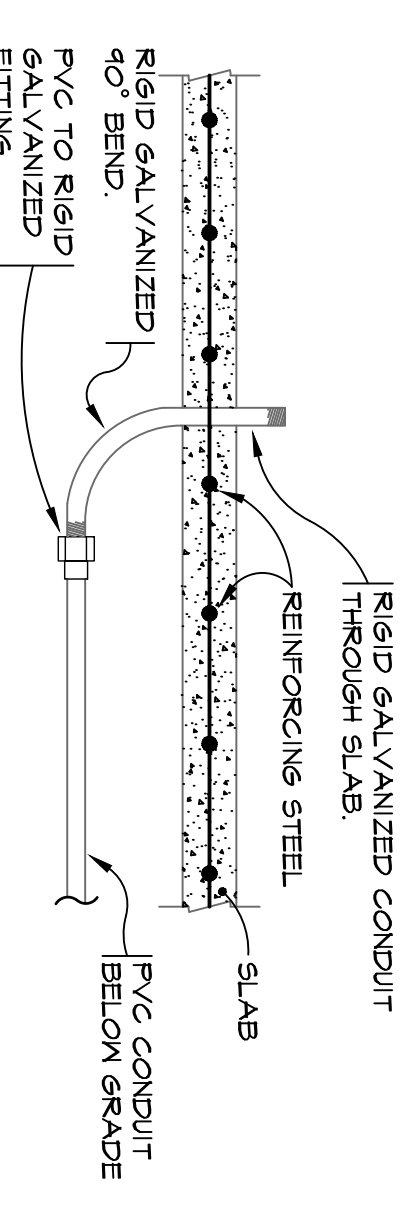

3 TYPICAL CONDUIT THROUGH SLAB NOT TO SCALE

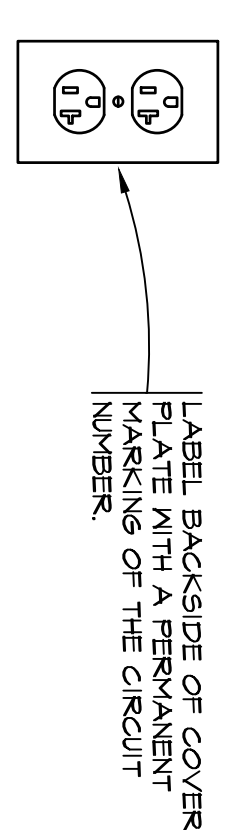

2 RECEPTACLE DETAIL NOT TO SCALE

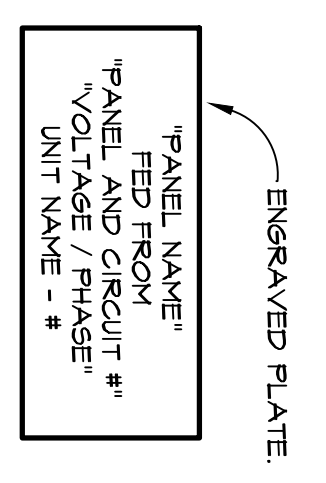

1 EQUIPMENT SIGNAGE (REQUIRED AT ALL DISCONNECTS AND PANELS) NOT TO SCALE

- GENERAL NOTES:** (APPLIES TO ALL SHEETS)
1. ALL CONDUCTORS SHALL BE COPPER.
 2. ALL WIRING SHALL BE IN CONDUIT, UNLESS SPECIFICALLY INDICATED OTHERWISE.
 3. NO MORE THAN THREE PHASE (NOT) CONDUCTORS SHALL BE RUN IN A SINGLE RACEWAY, HOWEVER MORE THAN THREE (3) CURRENT CARRYING CONDUCTORS ARE IN A SINGLE RACEWAY (PHASE PLUS NEUTRALS), THESE CONDUCTORS SHALL BE DERATED IN ACCORDANCE WITH NEC TABLE 310.15 (B) (2) (G).
 4. MAXIMUM LENGTH OF FIXTURE WIRING SHALL BE 6'-0".
 5. MC CABLE IS NOT AN APPROVED WIRING METHOD.
 6. PVC CONDUIT SHALL NOT BE USED ABOVE GRADE TRANSITION FROM PVC TO RIGID 6" BELOW SLAB, PENETRATE SLAB WITH RIGID CONDUIT A MINIMUM OF 5'.
 7. NO CONDUIT SHALL BE RUN IN SLABS.
 8. CONTRACTOR SHALL HANG ALL FIXTURES FROM STRUCTURE WITH MINIMUM OF TWO HANGERS.
 9. CONTRACTOR SHALL VISIT SITE PRIOR TO BID TO EXAMINE EXISTING CONDITIONS, SAME SHALL BE CONSIDERED IN BID. CONTRACTOR SHALL INFORM THIS OFFICE PRIOR TO LAST ADDENDUM IN THE EVENT THAT EXISTING CONDITIONS HINDER WORK CALLED FOR ON DRAWINGS.
 10. CONTRACTOR SHALL CUT AND PATCH OR BORE UNDER ALL EXISTING SIDEWALKS, DRIVEWAYS, ETC. AS NEEDED FOR NEW CONDUIT INSTALLATION.
 11. CONTRACTOR SHALL BE RESPONSIBLE FOR COORDINATING ELECTRICAL BREAKER SIZES WITH ACTUAL MECHANICAL EQUIPMENT FOR MECHANICAL EQUIPMENT ACTUALLY BEING INSTALLED.
 12. ALL EMPTY CONDUITS SHALL INCLUDE PULLSTRING FOR FUTURE.
 13. CONTRACTOR SHALL CONTACT ALL UTILITIES PRIOR TO BID AND BEYOND ANY CHANGES FOR SERVICES OUTLINED. ALL COST SHALL BE INCLUDED IN BID.
 14. PLANS AND SPECIFICATIONS SHALL BE CONSIDERED MINIMUM STANDARDS.
 15. ALL CIRCUITS SHALL CONTAIN AN INSULATED GROUND CONDUCTOR IN ADDITION TO PHASE AND NEUTRAL CONDUCTORS INDICATED ON PLANS AND IN PANEL SCHEDULES.
 16. ALL CONDUIT ON EXTERIOR OF BUILDING SHALL BE RIGID GALVANIZED STEEL.
 17. NON-METALLIC FLEXIBLE CONDUIT IS NOT AN APPROVED WIRING METHOD.
 18. ALL SWITCHES AND RECEPTACLES SHALL BE RATED 20 AMPS MINIMUM.
 19. MINIMUM CONDUIT SIZE SHALL BE 1/2".
 20. MINIMUM WIRE SIZE SHALL BE #12.
 21. ALL ELECTRICAL WORK SHALL BE DONE BY QUALIFIED LICENSED ELECTRICIANS.
 22. DO NOT COMBINE HONERING, MULTIPLE HOTS IN A SINGLE JUNCTION BOX OR DEVICE SHALL BE ON A SMALL TYPICALS DISCONNECTING HANDLE THE OR COMMON TRIP BREAKER.
 23. CIRCUIT DIRECTORY, EVERY CIRCUIT AND CIRCUIT MODIFICATION SHALL BE IDENTIFIED AS TO ITS CLEAR, EVIDENT AND SPECIFIC PURPOSE OF USE. THE IDENTIFICATION SHALL INCLUDE SUFFICIENT DETAIL TO ALLOW EACH CIRCUIT TO BE DISTINGUISHED FROM ALL OTHERS. SPARE POSITIONS SHALL BE DESCRIBED ACCORDINGLY AS PER NEC SECTION 408.4.
 24. CONTRACTOR SHALL REVIEW THE ENTIRE SPECIFICATIONS/ PROJECT FOR ADDITIONAL REQUIREMENTS DETAILED IN OTHER DIVISIONS SECTIONS INCLUDING BUT NOT LIMITED TO FOOD SERVICE, DOOR HANDLING, SEWER TREATMENT AND DIVISION 19).
 25. THE CONTRACTOR SHALL BE RESPONSIBLE FOR DETERMINING THE EXACT LOCATION, DEPTH AND SIZE OF ALL EXISTING UNDERGROUND UTILITIES AND STRUCTURES PRIOR TO EXCAVATION AND SHALL BE RESPONSIBLE FOR MARKING AND IDENTIFYING ALL UTILITIES TO BE COMPLETED BY THE APPROPRIATE LICENSED CONTRACTOR.
 26. CONTRACTOR TO PROVIDE PERMANENT MARKING OF PHASE ROTATION AT MAIN SERVICE INTERIOR PANEL.
 27. CONTRACTOR TO USE METERS, HUB CONNECTORS AT JUNCTION BOXES, TROUGHS, ETC. PENETRATIONS (INCLUDING SIDE PENETRATIONS).

SYMBOL SCHEDULE (APPLIES TO ALL SHEETS)

SYMBOL	DESCRIPTION
⊕	DUPLEX RECEPTACLE NEMA 5-20R, MOUNTED 18" AFF LEVEL IN COLOR UNLESS OTHERWISE NOTED.
▬	PANELBOARD FLUSH MOUNTED UNLESS INDICATED OTHERWISE.
J-BOX	J-BOX
⊙	ELECTRIC MOTOR
⊖	DISCONNECT SWITCH
⊕	LED LIGHT FIXTURE
⊕	MOTOR RATED TOGGLE SWITCH WITH THERMAL PROTECTION
⊕	INDIVIDUAL CIRCUIT RUN DIRECTLY TO PANEL FROM THIS POINT. (DO NOT COMBINE HONORINGS)
⊕	CONDUIT CONCEALED IN WALL OR CEILING.
⊕	CONDUIT RUN BELOW FLOOR OR SLAB.
⊕	COUNTERTOP: MTD, 4" CL ABOVE COUNTER BACKSPLASH, MOUNTED HORIZONTALLY.
⊕	WATERPROOF
⊕	GROUND FAULT CIRCUIT INTERRUPTER WEATHER RESISTANT TYPE DEVICE WHERE LOCATED IN DAMP OR WET LOCATIONS.
⊕	FUSED DISCONNECT SWITCH
⊕	VERIFY ON JOB
⊕	COPPER
⊕	ABOVE FINISHED FLOOR
⊕	NON-FUSED SWITCH
⊕	MOUNTED
⊕	ISOLATED GROUND DEVICE
⊕	TYPICAL
⊕	RIGID GALVANIZED STEEL
⊕	WIREWAY WITH INDIVIDUAL DISCONNECTS.
⊕	MOTORIZED DAMPER (CONNECT TO NEARBY 120V).

NOT ALL SYMBOLS APPLY TO EVERY PROJECT. ALL DIMENSIONS TO MIDDLE OF DEVICE UNLESS INDICATED OTHERWISE ON FLOOR PLAN.

"MC"

VOLTAGE: 120/208V, 3 PHASE, 4 WIRE
 MOUNTING SURFACE
 NEMA: 3R
 USE: YES NO X
 TYPE: PANELBOARD

* ALL BREAKERS HVAC RATED.

MAIN: 200A MB (SHUNT TRIP)
 AIC: XXXXX
 LOAD: 210 KW

DESCRIPTION	WIRE	MIN COND	BRKR AMPS NO.	CCT NO.	BRKR AMPS	WIRE	MIN COND	DESCRIPTION
RH-3	3-#4	1-#0 1/4"	TOA 1	4	TOA	3-#4	1-#0 1/4"	RH-2
RH-1	3-#4	1-#0 1/4"	TOA 7	6	TOA	3-#4	1-#0 1/4"	RH-4
RH-5	3-#0	1-#0 1"	35A 13	12	60A	3-#0	1-#0 1/4"	IOB-2B
			35A 13	18	60A			IOB-2A
IOB-1B	3-#6	1-#0 1/4"	60A 19	20	60A	3-#6	1-#0 1/4"	IOB-5A
IOB-1A	3-#6	1-#0 1/4"	60A 25	24	60A	3-#6	1-#0 1/4"	IOB-2B
IOB-4B	3-#6	1-#0 1/4"	60A 31	32	60A	3-#6	1-#0 1/4"	IOB-2A
IOB-4A	3-#6	1-#0 1/4"	60A 37	38	20A	2-#12	#12 3/4"	EH-1
CONTROLS	2-#12	#12 3/4"	30A 43	44	20A	2-#12	#12 3/4"	EH-2
SPARE	--	--	30A 45	46	20A	2-#12	#12 3/4"	EH-3
SPARE	--	--	60A 49	50	25A	3-#10	#10 3/4"	HOTSY
			60A 49	51				
				54				

"MD22"

VOLTAGE: 120/208V, 3 PHASE, 4 WIRE
 MOUNTING SURFACE
 NEMA: 1
 USE: YES NO X
 TYPE: PANELBOARD

PROVIDE 120KA PHASE INTERLOCK TISS.

MAIN: 1200A MB
 AIC: XXXXX
 LOAD: XXX KW

DESCRIPTION	WIRE	MIN COND	BRKR AMPS NO.	CCT NO.	BRKR AMPS	WIRE	MIN COND	DESCRIPTION
PANEL "MD"	SEE RISER DRAWING	DIAGRAM	300A 1	2	TOA	SEE RISER DRAWING	DIAGRAM	PANEL "MC"
SPD	--	--	100A 7	8	225A	SEE RISER DRAWING	DIAGRAM	PANEL AT HALL IOB
SPACE	--	--	200A 13	14	200A	--	--	SPARE
			200A 13	15				
				17				

DATE: 7/27/23
 REVISED:
 DRAWN BY: DL
 CHECKED BY: AD
 SHEET:
E4
 4 OF 4 SHEETS

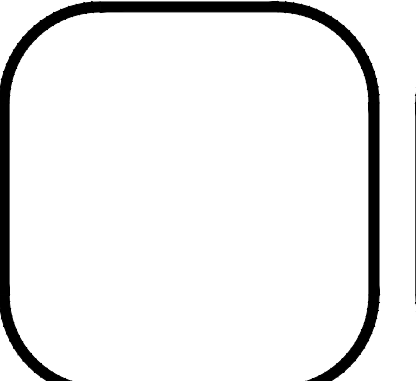

CONSULTING ENGINEERS
 204 WINCHESTER DRIVE, SUITE 2B
 LAFAYETTE, LOUISIANA 70506
 OFFICE: (337) 981-4665
 E-MAIL: TAENGR@THOMASSEEDASSOCIATES.COM

NEW IBERIA RESEARCH CENTER
 BUILDING 10-B - ELECTRICAL MODIFICATIONS

UL PHYSICAL PLANT
 AT THE UNIVERSITY OF LOUISIANA AT LAFAYETTE
 P.O. BOX 43646
 LAFAYETTE, LOUISIANA 70504

