



STATE OF LOUISIANA
DEPARTMENT OF TRANSPORTATION AND DEVELOPMENT
TECHNICAL SPECIFICATIONS FOR

TRUCK, CAB & CHASSIS, 35,000# GVWR W/8 YD. DUMP BODY AND HOIST

SERIES NO. 144-000

REV. 10/4/2023

EQUIPMENT SPECIFICATION 144-000C

GENERAL

This specification sets forth the minimum requirements for a class 8 single unit, single axle truck, 35,000# gvwr with 8 yd. dump body and hoist.

Equipment shall be new, a production model of current manufacture, and must meet all state and Federal safety and emission standards in effect at time of order.

REPRESENTATIVE SPECIFICATIONS

A Freightliner M2-106 cab and chassis and a Warren F-series dump body, with appropriate options and standard features, was used to develop these specifications and establish equivalency evaluation criteria.

Equipment of similar style, type, character, quality, features, and purpose conforming to the following detailed requirements/specifications will be considered. For evaluation purposes, bidder's proposing an exception/equivalent option/feature to those specified herein, may be required to provide manufacturer/product information (catalogue sheets, detailed specifications, pictures, etc.). This information will be evaluated against the minimum requirements of this specification. Proposed submittals that are determined not to be equivalent to the established criteria will be rejected.

LOUISIANA AUTHORIZED DEALER(S)

Proposed item(s) must be from a manufacturer who has at least one (1) authorized dealer within the State of Louisiana where parts and service can be obtained. Authorized dealer(s) must have properly trained technicians plus all other resources necessary to perform warranty and repair services in complete accordance with the manufacturer's requirements. A letter certifying the ability to meet this requirement, inclusive of the company name(s) and address(es) of the Louisiana authorized dealer(s), should be supplied with the bid submittal and may be required prior to award.

DELIVERY & ACCEPTANCE

Vendor shall perform a test run of each unit to verify that all features and capabilities are operating properly at time of delivery. Documentation of testing may be required prior to acceptance by the Department.

Unit(s) must be delivered completely assembled (including all components, accessories, etc.) and ready for operation without any additional preparation including, but not limited to, ensuring all fluid levels are at their full mark, fuel tank(s) is full, all necessary lubrication has been performed, etc. A Louisiana safety inspection shall be performed on each vehicle prior to delivery and a Louisiana safety inspection sticker properly affixed.



Any unit delivered under this specification is subject to rejection if there is evidence of poor workmanship, by either the vendor or the original manufacturer. Noted defects and/or nonconformance findings may be corrected by the vendor. Corrections must be completed and approved by the Equipment Engineer or his representative prior to final acceptance.

Unit(s) shall be delivered "**on the ground**;" DOTD will not unload nor provide any unloading equipment to the vendor/delivery driver in order to offload the unit(s).

NOTE: The Department will have space available for equipment to be unloaded.

EACH UNIT MUST BE SUPPLIED WITH THE FOLLOWING DOCUMENTATION:

1. Notarized Bill of Sale
2. Certificate of Origin (MSO)
3. Dealer's Service Policy
4. Owner's/Operator's Manual(s)
 - a. One (1) Hardcopy
 - b. One (1) Digital Copy
 - i. Acceptable Formats: PDF delivered via USB "Flash Drive", or E-mail
5. Service Manual(s)
 - a. One (1) Hardcopy
 - b. One (1) Digital Copy
 - i. Acceptable Formats: PDF delivered via USB "Flash Drive", or E-mail
6. Build Sheet(s) – as applicable
 - a. One (1) Hardcopy
 - b. Build sheets should be writing in plain language (not company specific codes) and include, at a minimum, all standard & optional features of the delivered unit.

NOTE: Invoices will not be processed for payment until the unit(s) have been inspected by the Equipment Engineer or their representative and deemed in compliance with the specifications.

BID SUBMITTALS

Any additions, deletions, or variations from the specifications should be noted in the "Bidder's Exceptions" page of this specification. Exceptions that are noted to be less than a minimum requirement will not be accepted.

Any additions, deletions or variations from the manufacturer's standard published specifications should be noted on the "Bidder's Exceptions" page of this specification. Unless otherwise noted, any items appearing in the manufacturer's standard published specifications furnished by the Bidder are assumed to be included in the Bidder's submittal.

Bidder should note on their submittal any installation(s) to the equipment that will be performed by the vendor instead of the manufacturer.

Failure to note any specification exceptions, manufacturer specification alterations, and/or vendor installations prior to award may result in rejection of the equipment at the time of delivery.

THE NUMBER OF DELIVERY DAYS AFTER RECEIPT OF ORDER (ARO) MAY BE USED AS A FACTOR IN THE AWARD.

EQUIPMENT SPECIFICATIONS

NOTICE TO BIDDERS

Bidder should review the detailed "Equipment Specification" completely and respond to the compliance question at the end of each section by marking "X", in the space provided, for "Yes" or "No". Mark "Yes" to indicate that the equipment bid meets the section exactly as specified. Mark "No" if there are exceptions to any part of that section. Exceptions/deviations to any part of the specification are to be detailed on the "Bidder's Exceptions" page of this specification.

IN ORDER TO BE CONSIDERED FOR AWARD, BIDDER SHOULD RETURN THIS SPECIFICATION, COMPLETED IN FULL, WITH THEIR BID SUBMITTAL.

Note: All Values listed below are minimums unless noted otherwise.

1. Cab & Chassis

1.1. GVWR: 35,000 lbs.

Comply: ___Yes ___No

1.2. Frame: 1,300,000 RBM (Resisting Bending Moment) - Bidder should list section modulus and yield strength below

Section Modulus: _____ Yield Strength: _____

Comply: ___Yes ___No

1.3. Cab & Axle Positions

1.3.1. Front axle: For the purposes of this solicitation, set-forward-axle (SFA) is considered equal to set-back-axle (SBA); however, SBA is the preferred option

1.3.2. Cab to Axle (CA): 83" clear*

1.3.3. Center of rear axle to end of frame (AF): 56"*

1.3.4. *Values given here are minimums. The space between cab and dump body shall not exceed 10 inches.

Truck vendor and dump body manufacturer/upfitter shall coordinate in selecting a cab to axle dimension that is compatible with the required body length and ensures proper load distribution to the front and rear axles in accordance with manufacturer specifications and industry practice.

Comply: ___Yes ___No

1.4. Front Bumper

1.4.1. Full width all-steel front bumper

1.4.2. Two (2) frame mounted tow hooks, one on each frame rail

Comply: ___Yes ___No

EQUIPMENT SPECIFICATIONS

1.5. Cab

- 1.5.1. Conventional day cab
- 1.5.2. Tinted safety glass
- 1.5.3. Full width exterior cab mounted sun shade with integral clearance lights
- 1.5.4. Cab entry handles, driver & passenger side
- 1.5.5. Outside mirrors, driver & passenger side
 - 1.5.5.1. Power adjustable
 - 1.5.5.2. 90 sq. in. minimum
 - 1.5.5.3. Heated with integrated turn signals
 - 1.5.5.4. Two (2) adjustable spot mirrors, one (1) per outside mirror
- 1.5.6. Two (2) roof mounted air horns & one (1) standard electric horn
- 1.5.7. Air ride: driver and passenger seat, cab suspension
- 1.5.8. Manufacturer's highest level sound insulation package
- 1.5.9. Wing dash, if available
- 1.5.10. Gauge package including the following gauges:
 - 1.5.10.1. Air cleaner restriction
 - 1.5.10.2. Coolant temperature
 - 1.5.10.3. DEF
 - 1.5.10.4. Fuel
 - 1.5.10.5. Oil pressure
 - 1.5.10.6. Primary and secondary air pressure
 - 1.5.10.7. Speedometer
 - 1.5.10.8. Tachometer
 - 1.5.10.9. Voltmeter
 - 1.5.10.10. Gear indicator
 - 1.5.10.11. Odometer
 - 1.5.10.12. Total engine hours
 - 1.5.10.13. Trip hours
 - 1.5.10.14. Trip odometer
 - 1.5.10.15. Rear axle oil temperature
 - 1.5.10.16. Auto transmission oil temperature
 - 1.5.10.17. Engine oil temperature
- 1.5.11. Dual sun visors
- 1.5.12. Two (2) cup holders, integral to dash
- 1.5.13. 3-point seat belt for each seat. All seat belt webbing must be manufacturer's high visibility color (Orange, Red, Green, or Yellow).
- 1.5.14. Climate control, including air conditioning, heater, & defroster
- 1.5.15. Power windows & power door locks
- 1.5.16. Tilting and telescoping steering wheel

Comply: ___ Yes ___ No

1.6. Engine

- 1.6.1. 7.7 L, electronic diesel, turbocharged, liquid cooled, 6-cylinder inline configuration

EQUIPMENT SPECIFICATIONS

- 1.6.2. 300 HP, 860 FT-LBS
- 1.6.3. Engine must include turbo exhaust brake
- 1.6.4. Emission system must include DEF
 - 1.6.4.1. DEF tank to be located on driver's side next to fuel tank
 - 1.6.4.2. DEF tank must have a minimum capacity of 7 gallons
- 1.6.5. Engine must be biodiesel compatible
- 1.6.6. Horizontal exhaust after-treatment (DPF) with vertical tail pipe

Comply: ___ Yes ___ No

1.7. Fuel System

- 1.7.1. Fuel tank shall be metal with drain and a 50-gallon minimum capacity; tank should be located on driver's side
- 1.7.2. Davco fuel processor or equal - mounted to outside of frame
- 1.7.3. Visual element change indication that is integral to and non-removable from unit (to be located on driver's side near fuel tank)
- 1.7.4. Water-in-fuel sensor with indicator in cab
- 1.7.5. Entire fuel system must be biodiesel compatible

Comply: ___ Yes ___ No

1.8. Transmission

- 1.8.1. Automatic, Allison 3500 RDS or equal
- 1.8.2. Must include PTO aperture
- 1.8.3. To be filled with manufacturer approved synthetic lubricants

Comply: ___ Yes ___ No

1.9. Gearing, Speed Governing & Performance

- 1.9.1. Top gear road speed shall be electronically governed at 75 mph maximum
- 1.9.2. Cruise control speed shall be governed at 72 mph maximum
- 1.9.3. Speed shall be governed at 10 mph when the dump bed is in any raised position
- 1.9.4. Transmission and axle ratio shall be selected for performance to be optimized at 65 while permitting truck to operate up to 75 MPH on highway without excessive engine speed. Bidder should list the RPM @ 65 MPH in the space below.

Comply: ___ Yes ___ No

RPM @ 65 MPH _____

1.10. PTO

- 1.10.1. PTO must be air shifted and compatible with specified transmission
- 1.10.2. PTO must be activated by dash mounted factory upfitter switch
 - 1.10.2.1. Indication of PTO engagement should be accomplished by lighted switch or separate dash mounted indicator light

Comply: ___ Yes ___ No

EQUIPMENT SPECIFICATIONS

1.11. Front Axle

- 1.11.1. 12,000 lbs. GAWR @ ground capacity (6,000 lbs. capacity per spring @ ground)
- 1.11.2. Shock absorbers
- 1.11.3. Integral power steering
- 1.11.4. Wet-type, visible cap axle seals, Stemco or equal
- 1.11.5. Axle should be filled with manufacturer approved synthetic lubricants

Comply: ___ Yes ___ No

1.12. Rear Axle

- 1.12.1. Single speed, 23,000 lbs. GAWR @ ground capacity
- 1.12.2. Air-ride suspension
- 1.12.3. Shock absorbers
- 1.12.4. Axle should be filled with manufacturer approved synthetic lubricants

Comply: ___ Yes ___ No

RPM @ 65 MPH _____

1.13. Brakes

- 1.13.1. Full air disc brake system, ABS brake system with traction control
- 1.13.2. 18 CFM air compressor
- 1.13.3. Bendix AD-9 air dryer or equal
- 1.13.4. Bendix Wingman[®] Fusion™ Advanced Driver Assistance System, or approved equal
- 1.13.5. Brake canisters must be rotated to avoid interference with asphalt paver

Comply: ___ Yes ___ No

1.14. Wheels & Tires

- 1.14.1. Hub piloted steel disc, size - 8.25 X 22.5
- 1.14.2. First line, first quality tires, size – 11R22.5
- 1.14.3. Front tires - single highway tread
- 1.14.4. Rear tires - dual on/off road tread
- 1.14.5. Load ratings to be compatible with GVWR
- 1.14.6. Spare tire, jack, & lug wrench are NOT required

Comply: ___ Yes ___ No

1.15. Electrical System & Lights

- 1.15.1. 12-volt system
- 1.15.2. 180-amp brushless alternator
- 1.15.3. Batteries with 2200 CCA combined
- 1.15.4. Aluminum battery box
- 1.15.5. Remote jump start studs, with tethered protective caps, located outside of the battery box
- 1.15.6. Battery disconnect switch, located inside cab, near driver's seat, similar to the below picture.

EQUIPMENT SPECIFICATIONS



- 1.15.7. Four (4) dash mounted, rocker-style, factory installed, body circuit switches (upfitter switches) for simple on/off functions for accessories (PTO, warning lights, etc.; one (1) assigned to activate the PTO; one (1) assigned to operate the flashing warning lights; two (2) blank to be assigned by DOTD personnel.
- 1.15.8. All exterior lighting, except headlights, should be LED
- 1.15.9. Headlights:
 - 1.15.9.1. Automatic daytime running lights
 - 1.15.9.2. Automatic on if windshield wipers are turned on
 - 1.15.9.3. Automatic on with low ambient light levels
 - 1.15.9.4. Warning buzzer/alarm when headlight switch is on and ignition switch is in off position
- 1.15.10. Cruise control
- 1.15.11. Intermittent windshield wipers with washers
- 1.15.12. Self-cancelling directional signals
- 1.15.13. Backup alarm, 97 dba
- 1.15.14. AM/FM/WB radio with auxiliary front input, Bluetooth/hands free function and steering wheel controls
- 1.15.15. Two (2) 12V accessory power outlets with covers, mounted in dash (for cell phone chargers, GPS devices, etc.)

Comply: ___ Yes ___ No

1.16. Paint

- 1.16.1. Cab: Manufacturer's standard, white
- 1.16.2. Chassis: Manufacturer's standard, black

Comply: ___ Yes ___ No

1.17. FMCSA/DOT Mandated Safety Items

- 1.17.1. One (1) UL listed, 5 B:C rated, or higher, fire extinguisher securely mounted in cab
- 1.17.2. One (1) set of three (3) bidirectional reflective triangles conforming to FMVSS No. 125
- 1.17.3. At least one (1) spare fuse for each type/size used in the truck

Comply: ___ Yes ___ No

EQUIPMENT SPECIFICATIONS

Note: The truck vendor and attached equipment manufacturer/vendor must mutually resolve any unexpected truck/attached equipment component conflict with a sound and functional solution as a requirement of this specification.

2. Attached Equipment – Dump Body and Warning Lights

2.1. Dump Body Description

- 2.1.1. Eight (8) cubic yard water level
- 2.1.2. 10' 0" long
- 2.1.3. 7'3" inside width
- 2.1.4. 42" sides
- 2.1.5. 48" ends
- 2.1.6. 24" x full width cab protector
- 2.1.7. Dump body must be equipped with sub-frame

Comply: ___ Yes ___ No

2.2. Construction

- 2.2.1. All steel to be abrasion resistant ASTM AR-450 (min.)
 - 2.2.1.1. Floor: ¼" smooth steel, one-piece
 - 2.2.1.2. Sides: ¼" smooth steel
 - 2.2.1.3. Tailgate: ¼" smooth steel, single panel design with perimeter bracing only; no middle bracing required
 - 2.2.1.4. Front: ¼" smooth steel
 - 2.2.1.5. Longitudinals: 5" structural channel
 - 2.2.1.6. Crossmembers: 4" structural channel on 12" centers
 - 2.2.1.7. Picture below provided as a general representation of the smooth side and tailgate requirements



EQUIPMENT SPECIFICATIONS

- 2.2.1. Top of bottom rail to be sloped to avoid dirt buildup
- 2.2.2. 2" side to floor radius. Welded inserts are acceptable if they are of the same material (thickness, yield strength and chemical composition) as the floor and 100 percent (100%) continuously welded in place.
- 2.2.3. ALL welds, except crossmember to body floor, will be continuous
- 2.2.4. Horizontal, centered, box bracing running from the front corner post of body to the rear corner post is required.
- 2.2.5. The rear corner post to be full depth from the top of the gate to the bottom of the rear cross member, one piece fabricated to a box section of 4" X 8".
- 2.2.6. An 8" wrap around front corner post is required.
- 2.2.7. Rear bolster shall be full width of body and have height of 8" to cover ends of longitudinals.
- 2.2.8. There shall be eight (8) (four (4) per side) sideboard gussets with 2" X 6" steel tubing sideboards.
- 2.2.9. 8" weld-on dump apron, ¼" plate with ¼" side wings

Comply: ___ Yes ___ No

2.3. Tailgate

- 2.3.1. Air operated high lift tailgate
- 2.3.2. Air operated latches
- 2.3.3. Tailgate to have full perimeter box bracing
- 2.3.4. Tailgate hardware shall be mounted on top of rear corner post upper cap plate
- 2.3.5. Upper gate hinges to be 1¼" steel and of boomerang design
- 2.3.6. Upper hinges shall be self-cleaning, and shall rest on top of rear post with gate in closed position
- 2.3.7. Hinge pin and bottom gate pin to be 1¼" in diameter
- 2.3.8. Bottom pins to be reinforced with angle inside tailgate
- 2.3.9. Spreader chain to be ¾"
- 2.3.10. Lower hardware backing plate shall be 2" and fully welded into rear corner post
- 2.3.11. Rear cross shaft to have center support

Comply: ___ Yes ___ No

2.4. Body Installation

- 2.4.1. A rubber or plastic (Nylon or Delrin) sill spacer shall be used between the chassis frame and body subframe. WOOD SPACERS ARE NOT ALLOWED!
- 2.4.2. Body shall be bolted to frame using brackets or fishplates, similar to below. U-BOLTS ARE NOT ALLOWED!
 - 2.4.2.1. Where possible, the upfitter should use existing holes in the chassis frame web.
 - 2.4.2.2. Brackets

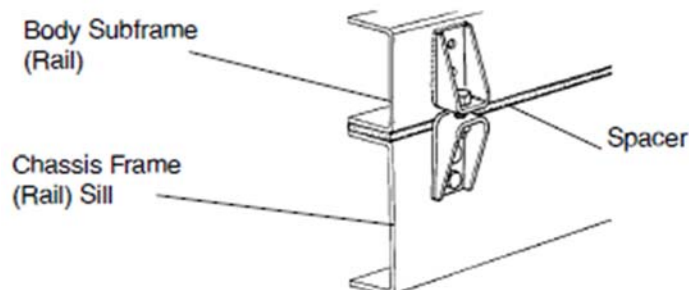

EQUIPMENT SPECIFICATIONS

2.4.2.3. Fishplates – To be bolted to chassis frame and bolted or welded to body subframe

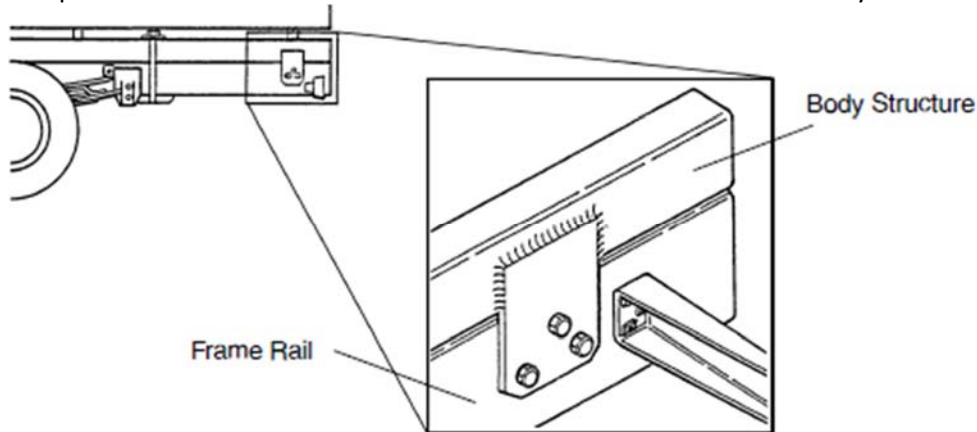

Comply: ___ Yes ___ No

2.5. Hoist

2.5.1. Front-mount, 3-stage telescopic, single ram, 29.4-ton capacity

2.5.2. NTEA Class 70 hoist

2.5.3. Hoist control(s) to be mounted in cab on floor mounted enclosed pedestal, with three (3) positions for dump body section of tandem hydraulic pump, within easy reach of driver

Comply: ___ Yes ___ No

2.6. Hydraulic System

2.6.1. Tandem, gear-type, hydraulic pump, 2,000 PSI rated, mounted directly to PTO

2.6.2. Pump section for dump body to be rated for 24 GPM @ 1500 RPM

2.6.3. Pump section for tailgate spreader to be rated for 18 GPM @ 1500 RPM

2.6.4. Pump shall be air-shifted and have control valve for flow metering and easy operator access.

2.6.5. Tailgate spreader section of hydraulic pump to be equipped with dual full pressure in-cab controls (Gresen Model QDB75AO7B16NA or approved equal)

2.6.6. Pressure relief for both sections set at 1500 PSI

2.6.7. To include dual remote hydraulic outlets located at back end of truck frame, attached to backing plate with bulkhead fittings. The fittings are to be capped (no quick connects required). The fittings are to be installed in a protected location so that future quick connects will not extend past the pintle hitch backing plate.

2.6.8. A hydraulic reservoir of 30-gallon capacity shall be mounted to outside of truck frame, complete with a replaceable cartridge-type return line hydraulic oil filter. Return line must not have any block valves in it, and any other block valve utilized must be a full port ball valve suitable for hydraulic oil service.

Comply: ___ Yes ___ No

EQUIPMENT SPECIFICATIONS

2.7. Trailer Hitch*

2.7.1. A 20-ton forged pintle hook mounted on $\frac{3}{4}$ " (min.) steel backing plate with two (2) $\frac{3}{4}$ " weld-on D-rings for safety chains. The backing plate shall be adequately gusseted and braced for the rated capacity of the pintle hook. In addition, the backside of the $\frac{3}{4}$ " backing plate shall be stiffened by a $\frac{3}{4}$ "x5" bar/plate welded to the backing plate, spanning the full width of the backing plate, centered with the pintle hook. See the included figure(s) below.

2.7.2. Pintle hitch mounting height: 27.5" from ground to center of lunette eye

2.7.3. $\frac{3}{4}$ " welded D-rings

2.7.4. Two (2) trailer electrical connection sockets: 7-pole semi & 7-pole RV style

2.7.5. Gladhands and hydraulic connections recessed and/or mounted away from the pintle hitch so there is no protrusion past pintle hitch backing plate

2.7.6. Recessed grommet mount stop/tail/turn/reverse/clearance lights

*The intent of this specification item and the included figure(s) is to get a single $\frac{3}{4}$ " steel plate coped to fit between the truck frame rails and welded to the frame. This plate shall serve as the mount for the aforementioned pintle hook, d-rings, lights, electrical connections, hydraulic connections & gladhands.

Comply: ___ Yes ___ No

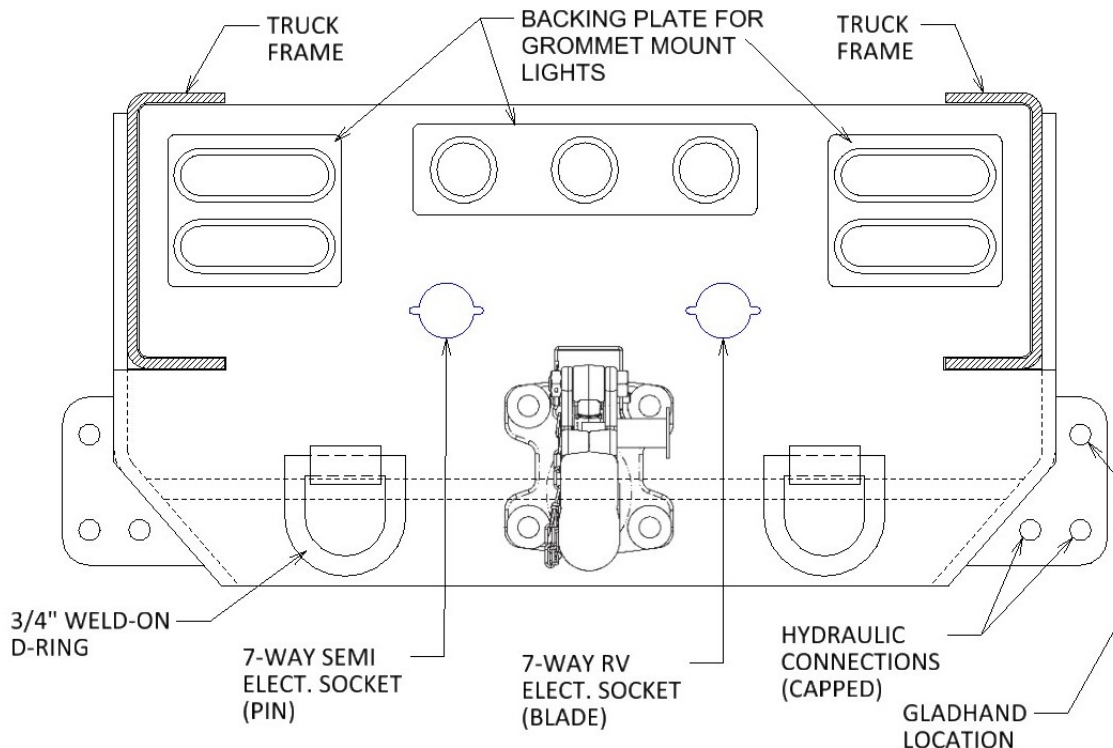

EQUIPMENT SPECIFICATIONS

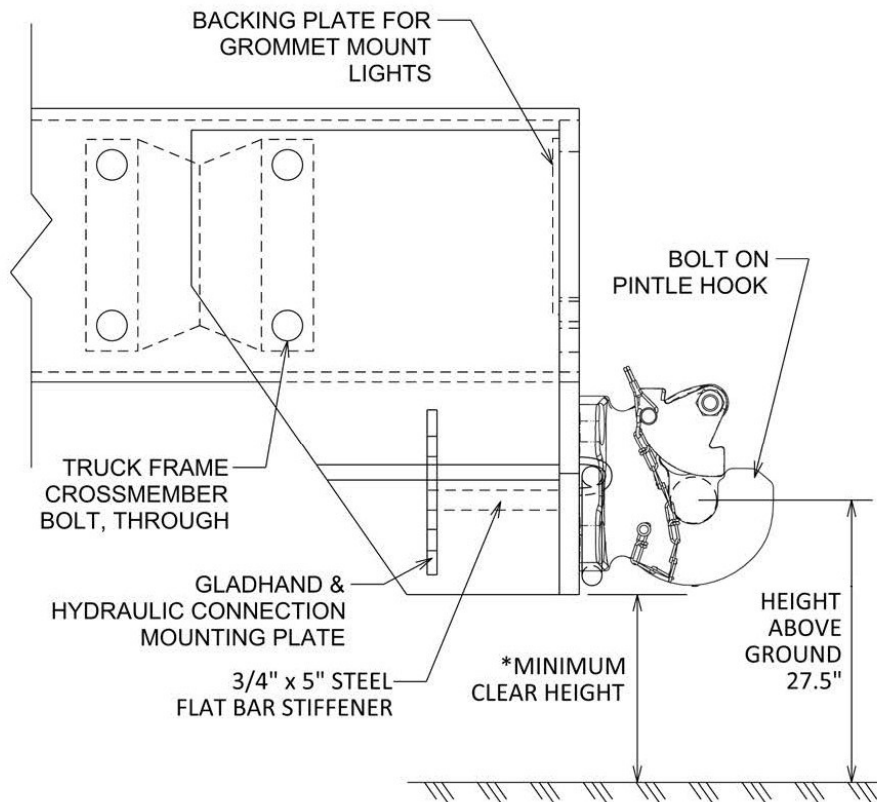

* NO PART OF THE TRAILER HITCH (PINTLE HOOK, MOUNTING PLATE, D-RINGS, HYDRAULIC CONNECTIONS, GLADHANDS, ETC.) SHALL BE LESS THAN 22" ABOVE GROUND LEVEL

2.8. Tarp System

- 2.8.1. Donavon "Bullet" or equal
- 2.8.2. 12-volt, direct drive motor, torsion arm design with in-cab controls
- 2.8.3. All wiring to be inside metal conduit
- 2.8.4. Tarp is to be asphalt lumite material, with the edges folded and sewn, and grommets installed every 24"
- 2.8.5. Tarp must also be resistant to punctures, abrasions and ultraviolet light

Comply: ___ Yes ___ No

2.9. Additional Accessories & Features

- 2.9.1. Two (2) sets of shovel brackets (one set on each side)
- 2.9.2. 3/8" thick rubber mud flaps
- 2.9.3. A 3-rung ladder plus one (1) under body step welded at the front of the dump bed, on each side, similar to the figure below:

EQUIPMENT SPECIFICATIONS



Comply: ___ Yes ___ No

2.10. Electrical & Lighting

2.10.1. Two (2) 6" oval grommet mount stop/turn/tail lights mounted in rear posts, with plug-in connectors

2.10.2. Flashing light to be mounted on the dash to notify the driver that the hoist is raised and the bed is in the up position



2.10.3. Dump body lighting wiring shall be incorporated into one (1) harness with only two (2) leads connecting into truck chassis lighting system

2.10.4. Dump body wiring shall be run inside metal conduit for protection

2.10.5. Truck must be delivered with warning lights & high visibility, reflective conspicuity tape installed in accordance with these specifications and the illustrated layout below

2.10.6. Warning lights shall be installed by an upfitter who is experienced in and regularly engages in the installation of automotive electronics & warning lights. Installer shall use vehicle & lighting manufacturers'

EQUIPMENT SPECIFICATIONS

guidance along with industry best practices and techniques to ensure that lights are installed in a safe and neat manner

- 2.10.7.** All wiring and cables should be logically routed, secured, and protected with convoluted loom where possible. Rubber grommets shall be used where wires and cables penetrate any cab panels, body panels, or chassis structure. All cab and body penetrations shall be adequately sealed to prevent water from entering.
- 2.10.8.** All warning lights must be controlled by a single in-cab, dash-mounted upfitter switch. The switch must be labeled to read "Warning Lights".
- 2.10.9.** Installer must contact the DOTD Equipment Section prior to programming to confirm intended flash pattern(s).
- 2.10.10.** Mid-size Light Bars - Two (2) mid-size (24") light bars that satisfy the following requirements, mounted to the cab protector as shown below
 - 2.10.10.1.** SoundOff Signal nRoads Mid-Size or equal
 - 2.10.10.2.** Length is nominal and +/- 1" is acceptable.
 - 2.10.10.3.** Dual color - 12 diodes per module (equal number of green & amber)
 - 2.10.10.4.** All modules shall be capable of fully displaying both colors.
 - 2.10.10.5.** Flash pattern must be capable of alternating between an asymmetric, low frequency, "wig-wag" pattern and a low-frequency double or quad flash.
 - 2.10.10.6.** UV resistant clear polycarbonate lens
 - 2.10.10.7.** 10-16 VDC
 - 2.10.10.8.** Light bars shall meet all applicable federal/state laws and regulations
 - 2.10.10.9.** Shall be SAE J845 360-degree Class 1 certified
- 2.10.11.** Perimeter Lights - Two (2) perimeter lights that satisfy the following requirements, mounted at grille level
 - 2.10.11.1.** Brooking Industries M16 surface mount perimeter lighthouse or equal satisfying the following requirements
 - 2.10.11.2.** Size: Length: 4.5-5.5 in., Height: 1.0-2.0 in., Depth: 0.3-0.5 in.
 - 2.10.11.3.** 12-24 VDC
 - 2.10.11.4.** UV resistant clear polycarbonate lens, black bezel trim
 - 2.10.11.5.** 16 diodes, dual color, equal number of green & amber (interleaved 8x8)
 - 2.10.11.6.** Lighthouse must be capable of displaying each color across full length
 - 2.10.11.7.** Capable of alternating between an asymmetric, low-frequency, "wig-wag" pattern and a low-frequency double or quad flash
 - 2.10.11.8.** Lighthouse shall meet all applicable federal/state laws and regulations
 - 2.10.11.9.** Shall be SAE J595 Class 1 certified
- 2.10.12.** Oval Warning Lights – Four 6" oval warning lights that satisfy the following requirements, two (2) mounted in cab protector and two (2) mounted in rear posts, as shown below
 - 2.10.12.1.** 6" L x 2¼" W , recessed, grommet, snap-in mount, LED
 - 2.10.12.2.** Polycarbonate lens
 - 2.10.12.3.** Dual color – half amber, half green
 - 2.10.12.4.** Must be capable of double or quad flash pattern
 - 2.10.12.5.** 12-24 VDC, with plug-in connector
 - 2.10.12.6.** Shall be SAE J595 Class 2 certified

Comply: ___ Yes ___ No

EQUIPMENT SPECIFICATIONS



2.11. Body Prep/Paint

- 2.11.1. Remove all weld spatter and slag, round sharp corners, grind sharp edges, buff all surfaces.
- 2.11.2. Prepare all metal surfaces (under structure and body) per paint manufacturer's requirements.
- 2.11.3. Prime all metal surfaces with PPG EPX Series high solids epoxy primer compatible with finish coat or equal
- 2.11.4. Primer to be 3-4 mils DFT
- 2.11.5. Apply finish coat of PPG Concept (DCC) Acrylic Urethane or equal
- 2.11.6. Color to be PPG No. 920247 gray or equal
- 2.11.7. Finish coat to be 4 mils DFT
- 2.11.8. Apply all coatings in strict accordance with manufacturer's recommendations
- 2.11.9. Note: Paint will be tested with a 7-mil magnet when it arrives at DOTD; if the paint is not in compliance, it will be rejected.

EQUIPMENT SPECIFICATIONS

2.11.10. High Visibility Reflective Tape

2.11.10.1. DOT C2 approved high visibility reflective conspicuity tape, 2" wide, with alternating 6" segments of red and white, shall be placed along each side and rear of the dump body as shown above.

Comply: ___Yes ___No

BIDDER'S EXCEPTIONS

Instructions: Bidder should note all exceptions in space provided below. List the detail number from the aforementioned specification in the column to the left and the exception in the column to the right. Responses may be typed or hand-written. Handwritten responses must be legible. If additional space is needed, please print a duplicate copy of this sheet. "Bidder's Exceptions" page(s) should be returned with the bid submittal.

Examples:

1.6	Engine has 325 horsepower
1.18.3	Batteries have 2000 CCA combined.
2.2.8	Crossmembers are 4" channel on 12" centers.

**Spec./Detail
Reference**

Exception

_____	_____
_____	_____
_____	_____
_____	_____
_____	_____
_____	_____
_____	_____
_____	_____
_____	_____
_____	_____
_____	_____
_____	_____
_____	_____
_____	_____
_____	_____
_____	_____
_____	_____
_____	_____
_____	_____
_____	_____
_____	_____
_____	_____