



ST. TAMMANY PARISH

MICHAEL B. COOPER
PARISH PRESIDENT

NOTICE TO BIDDERS

ST. TAMMANY PARISH

Sealed bids will be received by the Department of Procurement, until **2:00 p.m., Thursday, June 27, 2024**, and then opened and read publicly at that time by the Procurement Staff for the following project:

Bid # 24-22-2 – Tchefuncte Habitat Restoration

Each paper bid must be submitted in a sealed envelope. The outside of the envelope shall show the Name and Address of the Bidder, the State Contractor's License Number of the Bidder (if the work is estimated at \$50k or more), the Bid Name and the Bid Number.

The project classification is:

Heavy Construction: Dredging

This bid package is available online at www.bidexpress.com or LaPAC <https://wwwcfprd.doa.louisiana.gov/osp/lapac/pubmain.cfm>. It is the Vendor's responsibility to check Bid Express, or LaPAC frequently for any possible addenda that may be issued. The Parish is not responsible for a Vendor's failure to download any addenda documents required to complete a submission.

A Non-Mandatory pre-bid meeting will be held at the Staff Conference Room, 3rd Floor, located at St. Tammany Parish Government Administrative Complex, 21454 (Building B) Koop Drive, Mandeville, LA 70471 on Tuesday, June 4, 2024 at 10:00 am.

Bids will be received at 21454 Koop Dr., Suite 2F, Mandeville, LA 70471 from each bidder or his agent and given a written receipt, by certified mail with return receipt requested, or electronically at www.bidexpress.com.

Procurement Department

BID PROPOSAL

ST. TAMMANY PARISH
GOVERNMENT



BID PACKAGE FOR

TCHEFUNCTE HABITAT RESTORATION

BID NO.: 24-22-2

MAY 21, 2024

Section 01

Table of Contents

Section 01	Table of Contents
Section 02	Instructions to Bidders
Section 03	Summary of Work
Section 04	LA Uniform Public Work Bid Form Unit Price Form
Section 05	Affidavits, Louisiana (Pursuant to LSA-R.S. 38:2224, 38:2227 and 38:2212.10)
Section 06	Insurance Requirements
Section 07	Project Sign
Section 08	General Conditions
Section 09	Sample Corporate Resolution
Section 10	Sample Certificate of Insurance
Section 11	Sample Contract
Section 12	Technical Specifications
Section 13	Permits
Section 14	Plans
Section 15	Federal Grant Contract Clauses

Section 02

Instructions to Bidders

Bidders are urged to promptly review the requirements of this specification and submit questions for resolution as early as possible during the bid period. Questions or concerns must be submitted in writing to the Procurement Department no later than 2:00 CST seven (7) working days prior to the bid opening date. Otherwise, this will be construed as acceptance by the bidders that the intent of the specifications is clear and that competitive bids may be obtained as specified herein. Protests with regard to the specification documents will not be considered after bids are opened.

1. Bid security is required. Be sure that your bid includes such security as is necessary to meet Parish requirements and is properly signed. The bid must be fully completed. All applicable Louisiana license numbers must be affixed.
2. The Owner is the St. Tammany Parish Government (the "Parish").
3. The terms "he/his" and "it/its" may be used interchangeably.
4. The terms "Owner," the "Parish," and "St. Tammany Parish" may be used interchangeably.
5. The successful Bidder understands the limited contract time in the contract is **180 calendar days**, and shall submit any request for an extension of time in accordance with the General and Supplementary Conditions. Said request will reflect the days requested and the reason for same. No extension request is guaranteed or absolute.
6. Bidder specifically understands that acknowledgment of the General Conditions is required. Bidder specifically understands that signature of receipt of the General Conditions is mandated. **The Bidder's signature on the "Louisiana Uniform Public Work Bid Form" will serve as acknowledgment of the Bidder's receipt and understanding of the General Conditions as well as any Supplementary Conditions.**
7. ***If any additional work is performed by the contractor without written approval by owner, the cost of the work will be borne by the contractor and will not be reimbursed by the Parish.***
8. **Only** the Louisiana Uniform Public Bid Form, the Unit Price Form (if necessary), the bid security, and written evidence of authority of person signing the bid shall be submitted on or before the bid opening time and date provided for in the Bid Documents. Necessary copies of the Louisiana Uniform Public Work Forms and Unit Price Forms (if necessary) will be furnished for Bidding. Bound sets of the Contract Documents are for Bidder's information and should not be used in submitting Bids.
9. All other documents and information required are to be submitted by the low Bidder within ten (10) days after the opening of the bids, and at the same time of day and location as given for the opening of the bids in the Bid Documents.
10. Each Bid must be submitted in a sealed envelope, unless submitted electronically. The outside of the envelope shall show the name and address of the Bidder, the State Contractor's License Number of the Bidder (if work requires contractor's license), and the Project name and the Bid number. In the case of an electronic bid proposal, a contractor may submit an authentic digital signature on the electronic bid proposal accompanied by the contractor's license number, Project name and the Bid number.
11. The price quoted for the Work shall be stated in words and figures on the Bid Form, and in figures only on the Unit Price Form. The price in the Bid shall include all costs necessary for the complete performance of the Work in full conformity with the conditions of the Contract Documents, and shall include all applicable Federal, State, Parish, Municipal or other taxes. The price bid for the items listed on the Unit Price Form will include the cost of all related items not listed, but which are normally required to do the type of Work bid.
12. The Bid shall be signed by the Bidder. The information required on the Louisiana Uniform Public Work Bid Form must be provided. Evidence of agency, corporate, or partnership authority is required and shall be provided in conformance with LSA-R.S. 38:2212(B).

13. Only a Contractor licensed by the State to Heavy Construction Dredging as indicated on the Notice to Bidders can submit a Bid. The Bidder's signature on the Bid Form certifies that he holds an active license under the provisions of Chapter 24 of Louisiana Revised Statutes Title 37. Failure to be properly licensed constitutes authority for the Owner to reject the Bid.
14. Bidders shall not attach any conditions or provisions to the Bid. Any conditions or provisions so attached may, at the sole option of the Owner, cause rejection of the Bid.
15. A Bid Guarantee of five percent (5%) of the amount of the total Bid, including Alternates, must accompany the Proposal and, at the option of the Bidder, may be a cashier's check, certified check or a satisfactory Bid Bond. The Bid Guarantee must be attached to the Louisiana Uniform Public Work Bid Form. No Bid will be considered unless it is so guaranteed. Cashier's check or certified check must be made payable to the order of the Owner. Cash deposits will not be accepted. The Owner reserves the right to cash or deposit the cashier's check or certified check. Such guarantees shall be made payable to the Parish of St. Tammany. In accordance with LSA-R.S. 38:2218(C), if a bid bond is used, it shall be written by a surety or insurance company currently on the U.S. Department of the Treasury Financial Management Service list of approved bonding companies which is published annually in the Federal Register, or by a Louisiana domiciled insurance company with at least an A- rating in the latest printing of the A.M. Best's Key Rating Guide to write individual bonds up to ten percent of policyholders' surplus as shown in the A.M. Best's Key Rating Guide or by an insurance company in good standing licensed to write bid bonds which is either domiciled in Louisiana or owned by Louisiana residents. It is **not** required to be on any AIA form.
16. Bid securities of the three (3) lowest Bidders will be retained by the Owner until the Contract is executed or until final disposition is made of the Bids submitted. Bid securities of all other Bidders will be returned promptly after the canvas of Bids. Bids shall remain binding for forty-five (45) days after the date set for Bid Opening. The Parish shall act within the forty-five (45) days to award the contract to the lowest responsible bidder or reject all bids. However, the Parish and the lowest responsible bidder, by mutual written consent, may agree to extend the deadline for award by one or more extensions of thirty (30) calendar days. In the event the Owner issued the Letter of Award during this period, or any extension thereof, the Bid accepted shall continue to remain binding until the execution of the Contract.
17. A Proposal may be withdrawn at any time prior to the scheduled closing time for receipt of Bids, provided the request is in writing, executed by the Bidder or its duly authorized representative and is filed with the Owner prior to that time. When such a request is received, the Proposal will be returned to the Bidder unopened. A bid withdrawn under the provisions of LSA-R.S. 38:2214(C) cannot be resubmitted.
18. Written communications, over the signature of the Bidder, to modify Proposals will be accepted and the Proposal corrected in accordance therewith if received by the Owner prior to the scheduled closing time for receipt of Bids. Oral, telephonic or telegraphic Modifications will not be considered.
19. No oral interpretation obligating the Owner will be made to any Bidder as to the meaning of the Drawings, Specifications and Contract Documents. Every request for such an interpretation shall be made in writing and addressed and forwarded to the Owner. Inquiries received within seven (7) days prior to the day fixed for opening of the Bids may not be given consideration. Every interpretation made to the Bidder shall be in the form of an addendum to the Specifications. All such Addenda shall become part of the Contract Documents. Failure of the Owner to send or failure of Bidder to receive any such interpretation shall not relieve any Bidder from any obligation under this Bid as submitted without Modification. All Addenda shall be issued in accordance with the Public Bid Law, LSA-R.S. 38:2212(O).
20. The Owner reserves the right to reject any or all Bids for just cause in accordance with the Public Bid Law, LSA-R.S. 38:2214(B). Incomplete, informal, illegible, or unbalanced Bids may be rejected. Reasonable grounds for belief that any one Bidder is concerned directly or indirectly with more than one Bid will cause rejection of all Bids wherein such Bidder is concerned. If required, a Bidder shall furnish satisfactory evidence of its competence and ability to perform the Work stipulated in its Proposal. Incompetence will constitute cause

for rejection. If the Parish determines that the bidder is not responsive or responsible for any reason whatsoever, the bid may be rejected in accordance with State law.

21. Contractor shall be liable without limitation to the Parish for any and all injury, death, damage, loss, destruction, damages, costs, fines, penalties, judgments, forfeitures, assessments, expenses (including attorney fees), obligations, and other liabilities of every name and description, which may occur or in any way arise out of any act or omission of Contractor, its owners, agents, employees, partners or subcontractors.
22. Upon notice of any claim, demand, suit, or cause of action against the Parish, alleged to arise out of or be related to this Contract, Contractor shall investigate, handle, respond to, provide defense for, and defend at its sole expense, even if the claim, demand, suit, or cause of action is groundless, false, or fraudulent. The Parish may, but is not required to, consult with or assist the Contractor, but this assistance shall not affect the Contractor's obligations, duties, and responsibilities under this section. Contractor shall obtain the Parish's written consent before entering into any settlement or dismissal.
23. It is understood and agreed that neither party can foresee the exigencies beyond the control of each party which arise by reason of an Act of God or force majeure; therefore, neither party shall be liable for any delay or failure in performance beyond its control resulting from an Act of God or force majeure. The Parish shall determine whether a delay or failure results from an Act of God or force majeure based on its review of all facts and circumstances. The parties shall use reasonable efforts, including but not limited to, use of continuation of operations plans (COOP), business continuity plans, and disaster recovery plans, to eliminate or minimize the effect of such events upon the performance of their respective duties under this Contract.
24. Contractor shall fully indemnify and hold harmless the Parish, without limitation, for any and all injury, death, damage, loss, destruction, damages, costs, fines, penalties, judgments, forfeitures, assessments, expenses (including attorney fees), obligations, and other liabilities of every name and description, which may occur or in any way arise out of any act or omission of Contractor, its owners, agents, employees, partners or subcontractors. The Contractor shall not indemnify for the portion of any loss or damage arising from the Parish's act or failure to act.
25. Contractor shall fully indemnify and hold harmless the Parish, without limitation, from and against damages, costs, fines, penalties, judgments, forfeitures, assessments, expenses (including attorney fees), obligations, and other liabilities in any action for infringement of any intellectual property right, including but not limited to, trademark, trade-secret, copyright, and patent rights.

When a dispute or claim arises relative to a real or anticipated infringement, the Contractor, at its sole expense, shall submit information and documentation, including formal patent attorney opinions, as required by the Parish.

If the use of the product, material, service, or any component thereof is enjoined for any reason or if the Contractor believes that it may be enjoined, Contractor, while ensuring appropriate migration and implementation, data integrity, and minimal delays of performance, shall at its sole expense and in the following order of precedence: (i) obtain for the Parish the right to continue using such product, material, service, or component thereof; (ii) modify the product, material, service, or component thereof so that it becomes a non-infringing product, material, or service of at least equal quality and performance; (iii) replace the product, material, service, or component thereof so that it becomes a non-infringing product, material, or service of at least equal quality and performance; or, (iv) provide the Parish monetary compensation for all payments made under the Contract related to the infringing product, material, service, or component, plus for all costs incurred to procure and implement a non-infringing product, material, or service of at least equal quality and performance. Until this obligation has been satisfied, the Contractor remains in default.

The Contractor shall not be obligated to indemnify that portion of a claim or dispute based upon the Parish's unauthorized: i) modification or alteration of the product, material or service; ii) use of the product, material or service in combination with other products not furnished by Contractor; or, iii) use of the product, material or service in other than the specified operating conditions and environment.

26. Bidders shall familiarize themselves with and shall comply with all applicable Federal and State Laws, municipal ordinances and the rules and regulations of all authorities having jurisdiction over construction of the Project, which may directly or indirectly affect the Work or its prosecution. These laws and/or ordinances will be deemed to be included in the Contract, as though herein written in full.
27. Each Bidder shall visit the site of the proposed Work and fully acquaint itself with all surface and subsurface conditions as they may exist so that it may fully understand this Contract. Bidder shall also thoroughly examine and be familiar with drawings, Specifications and Contract Documents. The failure or omission of any Bidder to receive or examine any form, instrument, Drawing or document or to visit the site and acquaint itself with existing conditions shall in no way relieve any Bidder from any obligation with respect to its Bid and the responsibility in the premises.
28. The standard contract form enclosed with the Proposal documents is a prototype. It is enclosed with the Contract Documents for the guidance of the Owner and the Contractor. It has important legal consequences in all respects and consultation with an attorney is encouraged. Contractor shall be presumed to have consulted with its own independent legal counsel.
29. When one set of Contract plans show the Work to be performed by two or more prime Contractors, it is the responsibility of each Bidder to become knowledgeable of the Work to be performed by the other where the Work upon which this bid is submitted is shown to come into close proximity or in conflict with the Work of the other. In avoiding conflicts, pressure pipe lines must be installed to avoid conflict with gravity pipe lines and the Bidder of the smaller gravity pipe line in conflict with the larger gravity pipe line must include in his Bid the cost of a conflict box at these locations. The location of and a solution to the conflicts do not have to be specifically noted as such on the plans.
30. Bidder shall execute affidavit(s) attesting compliance with LSA-R.S. 38:2212.10, 38:2224, 38:2227, each as amended, and other affidavits as required by law, prior to execution of the contract.
31. In accordance with Louisiana Law, all Corporations (See LA R.S. 12:26.1) and Limited Liability Companies (See LA R.S. 12:1308.2) must be registered and in good standing with the Louisiana Secretary of State in order to hold a contract.
32. Sealed Bids shall be delivered to St. Tammany Parish Government at the office of **St. Tammany Parish Government, Department of Procurement, 21454 Koop Drive, Suite 2-F, Mandeville, LA 70471**, and a receipt given, until the time and date denoted in Notice to Bidders, at which time and place the Bids shall be publicly opened and read aloud to those present. In accordance with LSA-R.S. 38:2212(H), the designer's final estimated cost of construction shall be read aloud upon opening bids. Sealed Bids may also be mailed by certified mail to **St. Tammany Parish Government, Department of Procurement, 21454 Koop Drive, Suite 2-F, Mandeville, LA 70471**, and must be received before the bid opening. Bids may also be submitted electronically. Information concerning links for electronic bidding is contained in the Notice to Bidders. It is the responsibility of the Bidders to ensure that bids are delivered in a timely fashion. **Late bids, regardless of reason, will not be considered, and will be returned to bidder.**
33. Paper bids shall be placed in a sealed envelope, marked plainly and prominently as indicated in the Notice to Bidders, and these Instructions, and addressed:

**St. Tammany Parish Government
Department of Procurement
21454 Koop Drive, Suite 2-F
Mandeville, LA 70471**
34. See Notice to Bidders for availability of Drawings, Specifications and Contract Documents via electronic methods.
35. The successful Bidder shall be required to post in each direction a public information sign, 4' x 4' in size, at the location of the project containing information required by the Owner. The Owner shall supply this information.

36. The award of the Contract, if it is awarded, will be to the lowest responsible Bidder, in accordance with State Law. No award will be made until the Owner has concluded such investigations as it deems necessary to establish the responsibility and qualifications of the Bidder to do the Work in accordance with the Contract Documents to the satisfaction of the Owner within the time prescribed as established by the Department based upon the amount of work to be performed and the conditions of same. The written contract and bond shall be issued in conformance with LSA-R.S. 38:2216. If the Contract is awarded, the Owner shall give the successful Bidder written notice of the award within forty-five (45) calendar days after the opening of the Bids in conformance with LSA-R.S. 38:2215(A), or any extension as authorized thereunder.
37. At least three days prior to the execution of the Contract, the Contractor shall deliver to the Owner the required Bonds.
38. Failure of the successful Bidder to execute the Contract and deliver the required Bonds within ten (10) days of the Notice of the Award shall be just cause for the Owner to annul the award and declare the Bid and any guarantee thereof forfeited. Award may then be made to the next lowest responsible bidder.
39. In order to ensure the faithful performance of each and every condition, stipulation and requirement of the Contract and to indemnify and hold harmless the Owner from any and all damages, either directly or indirectly arising out of any failure to perform same, the successful Bidder to whom the Contract is awarded shall furnish a Performance and Payment Bond in an amount of at least equal to one hundred percent (100%) of the Contract Price. The Contract shall not be in force or binding upon the Owner until such satisfactory Bond has been provided to and approved by the Parish. The cost of the Bond shall be paid for by the Contractor unless otherwise stipulated in the Special Provisions.
40. No surety Company will be accepted as a bondsman which has no permanent agent or representative in the State upon whom notices referred to in the General Conditions of these Specifications may be served. Service of said notice on said agent or representative in the State shall be equal to service of notice on the President of the Surety Company, or such other officer as may be concerned.
41. In conformance with LSA-R.S. 38:2219(A)(1)(a), (b), and (c):
- Any surety bond written for a public works project shall be written by a surety or insurance company currently on the U.S. Department of the Treasury Financial Management Service list of approved bonding companies which is published annually in the Federal Register, or by a Louisiana domiciled insurance company with at least an A- rating in the latest printing of the A.M. Best's Key Rating Guide, to write individual bonds up to ten percent of policyholders' surplus as shown in the A.M. Best's Key Rating Guide or by an insurance company that is either domiciled in Louisiana or owned by Louisiana residents and is licensed to write surety bonds.
- For any public works project, no surety or insurance company shall write a bond which is in excess of the amount indicated as approved by the U.S. Department of the Treasury Financial Management Service list or by a Louisiana domiciled insurance company with an A- rating by A.M. Best up to a limit of ten percent of policyholders' surplus as shown by A.M. Best; companies authorized by this Paragraph who are not on the treasury list shall not write a bond when the penalty exceeds fifteen percent of its capital and surplus, such capital and surplus being the amount by which the company's assets exceed its liabilities as reflected by the most recent financial statements filed by the company with the Department of Insurance.
- In addition, any surety bond written for a public works project shall be written by a surety or insurance company that is currently licensed to do business in the state of Louisiana. All contractors must comply with any other applicable provisions of LSA-R.S. 38:2219.
42. Should the Contractor's Surety, even though approved and accepted by the Owner, subsequently remove its agency or representative from the State or become insolvent, bankrupt, or otherwise fail, the Contractor shall immediately furnish a new Bond in another company approved by the Owner, at no cost to the Owner. The new Bond shall be executed under the same terms and conditions as the original Bond. The new bond shall be submitted within thirty (30) days of such time as the Owner notifies Contractor or from the time

Contractor learns or has reason to know that the original surety is no longer financially viable or acceptable to the Parish, whichever occurs first. In the event that Contractor fails or refuses to timely secure additional surety, then the Owner may secure such surety and thereafter deduct such cost or expense from any sum due, or to become due to Contractor.

43. The Contractor's bondsman shall obligate itself to all the terms and covenants of these Specifications and of contracts covering the Work executed hereunder. The Owner reserves the right to do Extra Work or make changes by altering, adding to deducting from the Work under the conditions and in the manner herein before described without notice to the Contractor's surety and without in any manner affecting the liability of bondsman or releasing it from any of its obligations hereunder.
44. The Bond shall also secure for the Owner the faithful performance of the Contract in strict accordance with plans, specifications, and other Contract Documents. It shall protect the Owner against all lien laws of the State and shall provide for payment of reasonable attorney's fees for enforcement of Contract and institution or concursus proceedings, if such proceedings become necessary. Likewise, it shall provide for all additional expenses of the Owner occurring through failure of the Contractor to perform.
45. The surety of the Contractor shall be and does hereby declare and acknowledge itself by acceptance to be bound to the Owner as a guarantor, jointly and in solido, with the Contractor, for fulfillment of terms of the Contract.
46. The performance Bond and Labor and Material Bond forming part of this Contract shall be continued by Contractor and its Surety for a period of one (1) year from date of acceptance of the Work/Project by Owner to assure prompt removal and replacement of all defective material, equipment, components thereof, workmanship, etc., and to assure payment of any damage to property of Owner or others as a result of such defective materials, equipment, workmanship, etc.
47. Contractor authorizes Parish to deduct from any payment due herein costs and service fees for recordation of this Contract in full or an excerpt hereof, or any revisions or modifications thereof as required by law. Contractor agrees to execute an excerpt or extract of this agreement for recordation purposes. If Contractor fails to execute such an excerpt, then the Parish shall file and record the entire Contract and all attachments at the expense of Contractor and Parish is hereby authorized to deduct all related costs from any proceeds due to the Contractor.
48. Contractor shall secure and maintain at its expense such insurance that will protect it and the Parish from claims for injuries to persons or damages to property which may arise from or in connection with the performance of Services or Work hereunder by the Contractor, his agents, representatives, employees, and/or subcontractors. The cost of such insurance shall be included in Contractor's bid.
49. The Contractor shall not commence work until it has obtained all insurance as required for the Parish Project. If the Contractor fails to furnish the Parish with the insurance protection required and begins work without first furnishing Parish with a currently dated certificate of insurance, the Parish has the right to obtain the insurance protection required and deduct the cost of insurance from the first payment due the Contractor. Further deductions are permitted from future payments as are needed to protect the interests of the Parish including, but not limited to, renewals of all policies.
50. Payment of Premiums: The insurance companies issuing the policy or policies shall have no recourse against the Parish of St. Tammany for payment of any premiums or for assessments under any form of policy.
51. Deductibles: Any and all deductibles in the described insurance policies shall be assumed by and be at the sole risk of the Contractor.
52. Authorization of Insurance Company(ies) and Rating: All insurance companies must be authorized to do business in the State of Louisiana and shall have an A.M. Best rating of no less than A-, Category VII.
53. Policy coverages and limits must be evidenced by Certificates of Insurance issued by Contractor's carrier to the Parish and shall reflect:

Date of Issue: Certificate must have current date.

Named Insured: The legal name of Contractor under contract with the Parish and its principal place of business shall be shown as the named insured on all Certificates of Liability Insurance.

Name of Certificate Holder: St. Tammany Parish Government, Office of Risk Management, P. O. Box 628, Covington, LA 70434

Project Description: A brief project description, including Project Name, Project Number and/or Contract Number, and Location.

Endorsements and Certificate Reference: All policies must be endorsed to provide, and certificates of insurance must evidence the following:

Waiver of Subrogation: The Contractor's insurers will have no right of recovery or subrogation against the Parish of St. Tammany, it being the intention of the parties that all insurance policy(ies) so affected shall protect both parties and be the primary coverage for any and all losses covered by the below described insurance. *Policy endorsements required for all coverages.*

Additional Insured: The Parish of St. Tammany shall be named as additional named insured with respect to general liability, marine liability, pollution/environmental liability, automobile liability and excess liability coverages. *Policy endorsements required.*

Hold Harmless: Contractor's liability insurers shall evidence their cognizance of the Hold Harmless and Indemnification in favor of St. Tammany Parish Government by referencing same on the face of the Certificate(s) of Insurance.

Cancellation Notice: Producer shall provide thirty (30) days prior written notice to the Parish of policy cancellation or substantive policy change.

54. The types of insurance coverage the Contractor is required to obtain and maintain throughout the duration of the Contract shall be designated by a separate document issued by the Office of Risk Management.
55. It is the intent of these instructions that they are in conformance with State Bid Laws. Should there be any discrepancy or ambiguity in these provisions, the applicable State Bid Law shall apply.
56. The letting of any public contract in connection with funds that are granted or advanced by the United States of America shall be subject to the effect, if any, of related laws of said United States and valid rules and regulations of federal agencies in charge, or governing use and payment of such federal funds.
57. Protests based on alleged solicitation improprieties that are apparent before bid opening, or the time set for receipt of initial proposals must be filed with and received by the Procurement Department BEFORE these times. Any other protest shall be filed no later than ten (10) calendar days after: the opening of the bid; the basis of the protest is known; or the basis of the protest should have been known (whichever is earlier).
58. It is the Parish's policy to provide a method to protest exclusion from a competition or from the award of a contract, or to challenge an alleged solicitation irregularity. It is always better to seek a resolution within the Parish system before resorting to outside agencies and/or litigation to resolve differences. All protests must be made in writing, and shall be concise and logically presented to facilitate review by the Parish. The written protest shall include:

The protester's name, address, and fax and telephone numbers and the solicitation, bid, or contract number;

A detailed statement of its legal and factual grounds, including a description of the resulting prejudice to the protester;

Copies of relevant documents;

All information establishing that the protester is an interested party and that the protest is timely; and

A request for a ruling by the agency; and a statement of the form of relief requested.

The protest shall be addressed to St. Tammany Parish Government Department of Procurement, P.O. Box 628, Covington, LA 70434

The protest review shall be conducted by the Parish Legal Department.

Only protests from interested parties will be allowed. Protests based on alleged solicitation improprieties that are apparent before bid opening, or the time set for receipt of initial proposals, must be filed with and received by the Department of Procurement BEFORE those deadlines.

Any other protest shall be filed no later than ten (10) calendar days after the basis of the protest is known, or should have been known (whichever is earlier).

The Parish will use its best efforts to resolve the protest within thirty (30) days of the date that it is received by the Parish. The written response will be sent to the protestor via mail and fax, if a fax number has been provided by the protestor. The protester can request additional methods of notification.

59. The last day to submit questions and/or verification on comparable products will be no later than 2:00 pm CST, seven (7) working days prior to the opening date of the bid/proposal due date. Further, any questions or inquiries must be submitted via fax to 985-898-5227, or via email to Procurement@stpgov.org. Any questions or inquiries received after the required deadline to submit questions or inquiries will not be answered.
60. St. Tammany Parish Government contracts to be awarded are dependent on the available funding and/or approval by members designated and/or acknowledged by St. Tammany Parish Government. At any time, St. Tammany Parish Government reserves the right to cancel the award of a contract if either or both of these factors is deficient.
61. Any action by the Parish to disqualify any Bidder on the grounds that they are not a responsible Bidder shall be conducted in accordance with LSA-R.S. 38:2212(X).
62. Failure to complete or deliver within the time specified or to provide the services as specified in the bid or response will constitute a default and may cause cancellation of the contract. Where the Parish has determined the contractor to be in default. The Parish reserves the right to purchase any or all products or services covered by the contract on the open market and to charge the contractor with the cost in excess of the contract price. Until such assessed charges have been paid, no subsequent bid or response from the defaulting contractor will be considered.
63. If any part of the provisions contained herein and/or in the Specifications and Contract for the Work shall for any reason be held invalid, illegal or unenforceable in any respect, such invalidity, illegality or unenforceability shall not affect any other provisions of this Agreement or attachment, but it shall be construed as if such invalid, illegal, or unenforceable provision or part of a provision had never been contained herein.

Section 03

Summary of Work

I. Work to Include:

The work of this project includes the construction of a vinyl sheet pile bulkhead with rip-rap protection around the existing peninsula of the Tchefuncte River Lighthouse (base bid), construction of a rock breakwater approximately 400' in length (alternate 1), and the construction of a pier 300' in length (alternate 2).

II. Location of Work:

Tchefuncte River Lighthouse and adjacent waterway.

T-8-S, R-10-E, St Tammany Parish, Louisisana.

30°22'46.63" N, 90°10'08.90" W

III. Documents: Bid Documents dated MAY 21, 2024, and entitled:

Tchefuncte Habitat Restoration

BID No. 24-22-2

IV. OTHER REQUIREMENTS (as applicable)

When not otherwise specified herein, all work and materials shall conform to the requirements of the Louisiana Department of Transportation and Development hereafter called LDOTD (2016 Edition of Louisiana Standard Specifications for Roads and Bridges).

Comply with the following permits included as part of the bid documents.

Table 3.1

Liquidated Damages	
Original Contract Amount	Daily Charge
Dollars	Dollars
0 - 250,000	500
250,000 – 1 Million	1,000
> 1 Million – 5 Million	1,500
> 5 Million – 10 Million	2,000
> 10 Million	3,000

- Parish reserves the right to increase the Daily charge rate due to additional provisions required in order to complete the project as described in the specifications

Section 04

LOUISIANA UNIFORM PUBLIC WORK BID FORM

TO: St. Tammany Parish Government
21454 Koop Dr., Suite 2F
Mandeville, La 70471

(Owner to provide name and address of owner)

BID FOR: TCHEFUNCTE HABITAT RESTORATION
PROJECT NO. DV20000135

BID No.24-22-2
(Owner to provide name of project and other identifying information.)

The undersigned bidder hereby declares and represents that she/he; a) has carefully examined and understands the Bidding Documents, b) has not received, relied on, or based his bid on any verbal instructions contrary to the Bidding Documents or any addenda, c) has personally inspected and is familiar with the project site, and hereby proposes to provide all labor, materials, tools, appliances and facilities as required to perform, in a workmanlike manner, all work and services for the construction and completion of the referenced project, all in strict accordance with the Bidding Documents prepared by: Digital Engineering and Imaging, Inc. and dated: May 2024.

(Owner to provide name of entity preparing bidding documents.)

Bidders must acknowledge all addenda. The Bidder acknowledges receipt of the following ADDENDA: (Enter the number the Designer has assigned to each of the addenda that the Bidder is acknowledging)

TOTAL BASE BID: For all work required by the Bidding Documents (including any and all unit prices designated "Base Bid" * but not alternates) the sum of:

Dollars (\$)

ALTERNATES: For any and all work required by the Bidding Documents for Alternates including any and all unit prices designated as alternates in the unit price description.

Alternate No. 1 : BREAKWATER: for the lump sum of:

Dollars (\$)

Alternate No. 2 : PIER: for the lump sum of:

Dollars (\$)

Alternate No. 3 (Owner to provide description of alternate and state whether add or deduct) for the lump sum of:

N/A Not Applicable Dollars (\$ Not Applicable)

NAME OF BIDDER:

ADDRESS OF BIDDER:

LOUISIANA CONTRACTOR'S LICENSE NUMBER:

NAME OF AUTHORIZED SIGNATORY OF BIDDER:

TITLE OF AUTHORIZED SIGNATORY OF BIDDER:

SIGNATURE OF AUTHORIZED SIGNATORY OF BIDDER **:

DATE:

THE FOLLOWING ITEMS ARE TO BE INCLUDED WITH THE SUBMISSION OF THIS LOUISIANA UNIFORM PUBLIC WORK BID FORM:

* The Unit Price Form shall be used if the contract includes unit prices. Otherwise it is not required and need not be included with the form. The number of unit prices that may be included is not limited and additional sheets may be included if needed.

** A CORPORATE RESOLUTION OR WRITTEN EVIDENCE of the authority of the person signing the bid for the public work as prescribed by LA R.S. 38:2212(B)(5).

BID SECURITY in the form of a bid bond, certified check or cashier's check as prescribed by LA R.S. 38:2218(A) attached to and made a part of this bid.

LOUISIANA UNIFORM PUBLIC WORK BID FORM UNIT PRICE FORM

TO:

St. Tammany Parish Government
 21454 Koop Drive, Suite 2F
 Mandeville, LA. 70471
(OWNER TO PROVIDE NAME AND ADDRESS OF OWNER)

BID FOR:

Tchefuncte Habitat Restoration
 Project No. DV20000135
 BID No. 24-22-2
(OWNER TO PROVIDE PROJECT NAME & OTHER IDENTIFYING INFO)

UNIT PRICES: This form shall be used for any & all work required by the Bidding Documents & described as unit prices. Amounts shall be stated in figures & only in figures.

Description:	<input checked="" type="checkbox"/> BASE BID OR <input type="checkbox"/> ALT # MOBILIZATION & DEMOBILIZATION			
REF NO.:	QUANTITY	UNIT OF MEASURE	UNIT PRICE	UNIT PRICE EXTENSION (Quantity times unit price)
1	1	LUMP SUM		
Description:	<input checked="" type="checkbox"/> BASE BID OR <input type="checkbox"/> ALT # VINYL SHEETPILE			
REF NO.:	QUANTITY	UNIT OF MEASURE	UNIT PRICE	UNIT PRICE EXTENSION (Quantity times unit price)
2	6000	SQUARE FEET		
Description:	<input checked="" type="checkbox"/> BASE BID OR <input type="checkbox"/> ALT # GEOTEXTILE			
REF NO.:	QUANTITY	UNIT OF MEASURE	UNIT PRICE	UNIT PRICE EXTENSION (Quantity times unit price)
3	600	SQUARE YARD		
Description:	<input checked="" type="checkbox"/> BASE BID OR <input type="checkbox"/> ALT # GEOGRID			
REF NO.:	QUANTITY	UNIT OF MEASURE	UNIT PRICE	UNIT PRICE EXTENSION (Quantity times unit price)
4	600	SQUARE YARD		

Wording for "description" is to be provided by the Owner. All Quantities Estimated. The Contractor will be paid based upon actual quantities as verified by the Owner.

UNIT PRICES: This form shall be used for any & all work required by the Bidding Documents & described as unit prices. Amounts shall be stated in figures & only in figures.

Description: <input checked="" type="checkbox"/> BASE BID OR <input type="checkbox"/> ALT # DREDGING, FILL, AND GRADING				
REF NO.:	QUANTITY	UNIT OF MEASURE	UNIT PRICE	UNIT PRICE EXTENSION (Quantity times unit price)
5	1	LUMP SUM		
Description: <input checked="" type="checkbox"/> BASE BID OR <input type="checkbox"/> ALT # RIP-RAP R200				
REF NO.:	QUANTITY	UNIT OF MEASURE	UNIT PRICE	UNIT PRICE EXTENSION (Quantity times unit price)
6	500	TON		
Description: <input checked="" type="checkbox"/> BASE BID OR <input type="checkbox"/> ALT # PILE REMOVAL				
REF NO.:	QUANTITY	UNIT OF MEASURE	UNIT PRICE	UNIT PRICE EXTENSION (Quantity times unit price)
7	50	EACH		
Description: <input type="checkbox"/> BASE BID OR <input checked="" type="checkbox"/> ALT # <u>1</u> MOBILIZATION & DEMOBILIZATION				
REF NO.:	QUANTITY	UNIT OF MEASURE	UNIT PRICE	UNIT PRICE EXTENSION (Quantity times unit price)
8	1	LUMP SUM		
Description: <input type="checkbox"/> BASE BID OR <input checked="" type="checkbox"/> ALT # <u>1</u> GEOTEXTILE				
REF NO.:	QUANTITY	UNIT OF MEASURE	UNIT PRICE	UNIT PRICE EXTENSION (Quantity times unit price)
9	3500	SQUARE YARD		

Wording for "description" is to be provided by the Owner. All Quantities Estimated. The Contractor will be paid based upon actual quantities as verified by the Owner.

UNIT PRICES: This form shall be used for any & all work required by the Bidding Documents & described as unit prices. Amounts shall be stated in figures & only in figures.

Description: <input type="checkbox"/> BASE BID OR <input checked="" type="checkbox"/> ALT # <u>1</u> GEOGRID				
REF NO.:	QUANTITY	UNIT OF MEASURE	UNIT PRICE	UNIT PRICE EXTENSION (Quantity times unit price)
10	3500	SQUARE YARD		
Description: <input type="checkbox"/> BASE BID OR <input checked="" type="checkbox"/> ALT # <u>1</u> #57 STONE (NET SECTION)				
REF NO.:	QUANTITY	UNIT OF MEASURE	UNIT PRICE	UNIT PRICE EXTENSION (Quantity times unit price)
11	1750	TON		
Description: <input type="checkbox"/> BASE BID OR <input checked="" type="checkbox"/> ALT # <u>1</u> RIP-RAP R650				
REF NO.:	QUANTITY	UNIT OF MEASURE	UNIT PRICE	UNIT PRICE EXTENSION (Quantity times unit price)
12	2600	TON		
Description: <input type="checkbox"/> BASE BID OR <input checked="" type="checkbox"/> ALT # <u>1</u> RIP-RAP R1500				
REF NO.:	QUANTITY	UNIT OF MEASURE	UNIT PRICE	UNIT PRICE EXTENSION (Quantity times unit price)
13	2600	TON		
Description: <input type="checkbox"/> BASE BID OR <input checked="" type="checkbox"/> ALT # <u>1</u> MARINE HAZARD MARKERS				
REF NO.:	QUANTITY	UNIT OF MEASURE	UNIT PRICE	UNIT PRICE EXTENSION (Quantity times unit price)
14	3	EACH		

Wording for "description" is to be provided by the Owner. All Quantities Estimated. The Contractor will be paid based upon actual quantities as verified by the Owner.

UNIT PRICES: This form shall be used for any & all work required by the Bidding Documents & described as unit prices. Amounts shall be stated in figures & only in figures.

Description: <input type="checkbox"/> BASE BID OR <input checked="" type="checkbox"/> ALT # <u>2</u> MOBILIZATION & DEMOBILIZATION				
REF NO.:	QUANTITY	UNIT OF MEASURE	UNIT PRICE	UNIT PRICE EXTENSION (Quantity times unit price)
15	1	LUMP SUM		
Description: <input type="checkbox"/> BASE BID OR <input checked="" type="checkbox"/> ALT # <u>2</u> WOODEN PIER WITH COMPOSITE DECK				
REF NO.:	QUANTITY	UNIT OF MEASURE	UNIT PRICE	UNIT PRICE EXTENSION (Quantity times unit price)
16	310	LINEAR FEET		
Description: <input type="checkbox"/> BASE BID OR <input checked="" type="checkbox"/> ALT # <u>2</u> PIER LANDING STAIRS WITH CONCRETE PAD				
REF NO.:	QUANTITY	UNIT OF MEASURE	UNIT PRICE	UNIT PRICE EXTENSION (Quantity times unit price)
17	1	LUMP SUM		
Description: <input type="checkbox"/> BASE BID OR <input checked="" type="checkbox"/> ALT # <u>2</u> WOODEN PILE				
REF NO.:	QUANTITY	UNIT OF MEASURE	UNIT PRICE	UNIT PRICE EXTENSION (Quantity times unit price)
18	51	EACH		

Wording for "description" is to be provided by the Owner. All Quantities Estimated. The Contractor will be paid based upon actual quantities as verified by the Owner.

Section 05

**AFFIDAVIT PURSUANT TO LSA-R.S. 38:2224 and 38:2227
FOR BIDDERS FOR PUBLIC WORKS CONTRACTS**

STATE OF _____

PARISH/COUNTY OF _____

BEFORE ME, the undersigned authority, in and for the above stated State and Parish (or County), personally came and appeared:

Print Name

who, after first being duly sworn, did depose and state:

1. That affiant is appearing on behalf of _____, who is seeking a public contract with St. Tammany Parish Government.

2. That affiant employed no person, corporation, firm, association, or other organization, either directly or indirectly, to secure the public contract under which he received payment, other than persons regularly employed by the affiant whose services in connection with the construction, alteration or demolition of the public building or project or in securing the public contract were in the regular course of their duties for affiant; and

3. That no part of the contract price received by affiant was paid or will be paid to any person, corporation, firm, association, or other organization for soliciting the contract, other than the payment of their normal compensation to persons regularly employed by the affiant whose services in connection with the construction, alteration or demolition of the public building or project were in the regular course of their duties for affiant.

4. If affiant is a sole proprietor, that after July 2, 2010, he/she has not been convicted of, or has not entered a plea of guilty or *nolo contendere* to any of the crimes or equivalent federal crimes listed in LSA-R.S. 38:2227(B).

5. If affiant is executing this affidavit on behalf of a juridical entity such as a partnership, corporation, or LLC, etc., that no individual partner, incorporator, director, manager, officer, organizer, or member, who has a minimum of a ten percent ownership in the bidding entity, has been convicted of, or has entered a plea of guilty or *nolo contendere* to any

of the crimes or equivalent federal crimes listed in LSA-R.S. 38:2227(B).

6. If affiant is a sole proprietor, that neither affiant, nor his/her immediate family is a public servant of St. Tammany Parish Government or the Contract is not under the supervision or jurisdiction of the public servant's agency.

7. If affiant is executing this affidavit on behalf of a juridical entity such as a partnership, corporation, or LLC, etc., that no public servant of St. Tammany Parish Government, or his/her immediate family, either individually or collectively, has more than a 25% ownership interest in the entity seeking the Contract with St. Tammany Parish Government if the Contract will be under the supervision or jurisdiction of the public servant's agency.

Printed Name: _____

Title: _____

Entity name: _____

THUS SWORN TO AND SUBSCRIBED BEFORE ME,
THIS _____, DAY OF _____, 202__.

Notary Public

Print Name: _____

Notary I.D./Bar No.: _____

My commission expires: _____

**AFFIDAVIT PURSUANT TO LSA-R.S. 38:2212.10 CONFIRMING
REGISTRATION AND PARTICIPATION IN A STATUS VERIFICATION
SYSTEM**

STATE OF _____

PARISH/COUNTY OF _____

BEFORE ME, the undersigned authority, in and for the above stated State and Parish (or County), personally came and appeared:

Print Name

who, after first being duly sworn, did depose and state:

1. That affiant is appearing on behalf of _____, a private employer seeking a bid or a contract with St. Tammany Parish Government for the physical performance of services within the State of Louisiana.

2. That affiant is registered and participates in a status verification system to verify that all employees in the state of Louisiana are legal citizens of the United States or are legal aliens; and

3. That affiant shall continue, during the term of the contract, to utilize a status verification system to verify the legal status of all new employees in the state of Louisiana.

4. That affiant shall require all subcontractors to submit to the affiant a sworn affidavit verifying compliance with this law.

Printed Name: _____

Title: _____

Name of Entity: _____

**THUS SWORN TO AND SUBSCRIBED BEFORE ME,
THIS _____, DAY OF _____, 202__.**

Notary Public
Print Name: _____
Notary I.D./Bar No.: _____
My commission expires: _____



SECTION 06

INSURANCE REQUIREMENTS*

Construction Project: Tchefuncte Habitat Restoration_____

Project/Quote/Bid#: 24-22-2_____

*****IMPORTANT – PLEASE READ*****

Prior to submitting your quote or bid, it is recommended that you review these insurance requirements with your insurance broker/agent.

These requirements modify portions of the insurance language found in the General Conditions and/or Supplementary General Conditions; however, there is no intention to remove all sections pertaining to insurance requirements and limits set forth in the General Conditions and/or Supplementary General Conditions, only to amend and specify those items particular for this Project.

- A. The Provider shall secure and maintain at its expense such insurance that will protect it and St. Tammany Parish Government (the "Parish") from claims for bodily injury, death or property damage as well as from claims under the Workers' Compensation Acts that may arise from the performance of services under this agreement. All certificates of insurance shall be furnished to the Parish and provide thirty (30) days prior notice of cancellation to the Parish, in writing, on all of the required coverage.
- B. All policies shall provide for and certificates of insurance shall indicate the following:
1. Waiver of Subrogation: The Provider's insurers will have no right of recovery or subrogation against the Parish of St. Tammany, it being the intention of the parties that all insurance policy(ies) so affected shall protect both parties and be the primary coverage for any and all losses covered by the below described insurance.
 2. Additional Insured: St. Tammany Parish Government shall be named as Additional Insured with respect to general liability, automobile liability and excess liability coverages, as well as marine liability and pollution/environmental liability, when those coverages are required or necessary.
 3. Payment of Premiums: The insurance companies issuing the policy or policies will have no recourse against St. Tammany Parish Government for payment of any premiums or for assessments under any form of policy.
 4. Project Reference: The project(s) and location(s) shall be referenced in the Comment or Description of Operations section of the Certificate of Insurance (Project ##-###, or Bid # if applicable, Type of Work, Location).
- C. Coverage must be issued by insurance companies authorized to do business in the State of Louisiana. Companies must have an A.M. Best rating of no less than A-, Category VII. St. Tammany Parish Risk Management Department may waive this requirement only for Workers Compensation coverage at their discretion.

Provider shall secure and present proof of insurance on forms acceptable to St. Tammany Parish Government, Office of Risk Management no later than the time of submission of the Contract to the Parish. However, should any work performed under this Contract by or on behalf of Provider include exposures that are not covered by those insurance coverages, Provider is not relieved of its obligation to maintain appropriate levels and types of insurance necessary to protect itself, its agents and employees, its subcontractors, St. Tammany Parish Government (Owner), and all other interested third parties, from any and all claims for damage or injury in connection with the services performed or provided throughout the duration of this Project, as well as for any subsequent periods required under this Contract.

The insurance coverages checked (✓) below are those required for this Contract.

1. **Commercial General Liability*** insurance – **Occurrence Form** - with a Combined Single Limit for bodily injury and property damage of at least \$1,000,000 per Occurrence / \$2,000,000 General Aggregate and \$2,000,000 Products-Completed Operations. Contracts over \$1,000,000 may require higher limits. The insurance shall provide for and the certificate(s) of insurance shall indicate the following coverages:
- a) Premises - operations;
 - b) Broad form contractual liability;
 - c) Products and completed operations;
 - d) Personal/Advertising Injury;
 - e) Broad form property damage (for Projects involving work on Parish property);
 - f) Explosion, Collapse and Damage to underground property.
 - g) Additional Insured forms CG 2010 and CG 2037 in most current edition are required.
2. **Business Automobile Liability*** insurance with a Combined Single Limit of \$1,000,000 per Occurrence for bodily injury and property damage, and shall include coverage for the following:
- a) Any auto;
- or**
- b) Owned autos; **and**
 - c) Hired autos; **and**
 - d) Non-owned autos.
3. **Workers' Compensation/Employers Liability insurance*** - Workers' Compensation coverage as required by State law. Employers' liability limits shall be a minimum of \$1,000,000 each accident, \$1,000,000 each disease, \$1,000,000 disease policy aggregate. When water activities are expected to be performed in connection with this project, coverage under the USL&H Act, Jones Act and/or Maritime Employers Liability (MEL) must be included. **Coverage for owners, officers and/or partners in any way engaged in the Project shall be included in the policy.** The names of any excluded individual must be shown in the Description of Operations/Comments section of the Certificate.
4. **Pollution Liability and Environmental Liability*** insurance in the minimum amount of \$1,000,000 per occurrence / \$2,000,000 aggregate including full contractual liability and third party claims for bodily injury and/or property damage, for all such hazardous waste, pollutants and/or environmental exposures that may be affected by this project stemming from pollution/environmental incidents as a result of Contractor's operations.

If coverage is provided on a claims-made basis, the following conditions apply:

- 1) the retroactive date must be prior to or coinciding with the effective date of the Contract, or prior to the commencement of any services provided by the Contractor on behalf of the Parish, whichever is earlier; AND
- 2) continuous coverage must be provided to the Parish with the same retro date for 24 months following acceptance or termination of the Project by the Parish either by
 - a) continued renewal certificates **OR**
 - b) a 24 month Extended Reporting Period

*The Certificate must indicate whether the policy is written on an occurrence or claims-made basis and, if claims-made, the applicable retro date must be stated.

5. **Contractor's Professional Liability/Errors and Omissions*** insurance in the sum of at least \$1,000,000 per claim / \$2,000,000 aggregate is required when work performed by Contractor or on behalf of Contractor includes professional or technical services including, but not limited to, construction administration and/or management, engineering services such as design, surveying, and/or inspection, technical services such as testing and laboratory analysis, and/or environmental assessments. An occurrence basis policy is preferred.

If coverage is provided on a claims-made basis, the following conditions apply:

- 1) the retroactive date must be prior to or coinciding with the effective date of the Contract, or prior to the commencement of any services provided by the Contractor on behalf of the Parish, whichever is earlier; AND
- 2) continuous coverage must be provided to the Parish with the same retro date for 24 months following acceptance or termination of the Project by the Parish either by
 - a) continued renewal certificates **OR**
 - b) a 24 month Extended Reporting Period

*The Certificate must indicate whether the policy is written on an occurrence or claims-made basis and, if claims-made, the applicable retro date must be stated.

6. **Marine Liability/Protection and Indemnity*** insurance is required for any and all vessel and/or marine operations in the minimum limits of \$1,000,000 per occurrence / \$2,000,000 per project general aggregate. The coverage shall include, but is not limited to, the basic coverages found in the Commercial General Liability insurance and coverage for third party liability

***Excess/Umbrella Liability** insurance may be provided to meet the limit requirements for any Liability coverage. For example: if the General Liability requirement is \$3,000,000 per occurrence, but the policy is only \$1,000,000 per occurrence, then the excess policy should be at least \$2,000,000 per occurrence thereby providing a combined per occurrence limit of \$3,000,000.)

7. **Owners Protective Liability (OPL)** shall be furnished by the Contractor and shall provide coverage in the minimum amount of \$1,000,000 CSL each occurrence / \$1,000,000 aggregate. **St. Tammany Parish Government, ATTN: Risk Management Department, P. O. Box 628, Covington, LA 70434 shall be the first named insured on the policy.**

8. **Builder's Risk Insurance** written as an "all-risk" policy providing coverage in an amount at or greater than one hundred percent (100%) of the completed value of the contracted project. Any contract modifications increasing the contract cost will require an increase in the limit of the Builder's Risk policy. Deductibles should not exceed \$5,000 and Contractor shall be responsible for all policy deductibles. This insurance shall cover materials at the site, stored off the site, and in transit. The Builder's Risk Insurance shall include the interests of the Owner, Contractor and Subcontractors and shall terminate only when the Project is accepted in writing. **St. Tammany Parish Government, ATTN: Risk Management Department, P. O. Box 628, Covington, LA 70434 shall be named as a Loss Payee on the policy.**

9. **Installation Floater Insurance**, on an "all-risk" form, shall be furnished by Contractor and carried for the full value of the materials, machinery, equipment and labor for each location. The Contractor shall be responsible for all policy deductibles. The Installation Floater Insurance shall provide coverage for property owned by others and include the interests of the Owner, Contractor and Subcontractors and shall terminate only when the Project is accepted in writing. **St. Tammany Parish Government, ATTN: Risk Management Department, P. O. Box 628, Covington, LA 70434 shall be named as a Loss Payee on the policy.**

- D. All policies of insurance shall meet the requirements of the Parish prior to the commencing of any work. The Parish has the right, but not the duty, to approve all insurance coverages prior to commencement of work. If any of the required policies are or become unsatisfactory to the Parish as to form or substance; or if a company issuing any policy is or becomes unsatisfactory to the Parish, the Provider shall promptly obtain a new policy, timely submit same to the Parish for approval, and submit a certificate thereof as provided above. The Parish agrees not to unreasonably withhold approval of any insurance carrier selected by Provider. In the event that Parish cannot agree or otherwise authorize a carrier, Provider shall have the option of selecting and submitting a new insurance carrier within 30 days of said notice by the Parish. In the event that the second submission is insufficient or is not approved, then the Parish shall have the unilateral opportunity to thereafter select a responsive and responsible insurance carrier all at the cost of Provider and thereafter deduct from Provider's fee the cost of such insurance.
- E. Upon failure of Provider to furnish, deliver and/or maintain such insurance as above provided, this contract, at the election of the Parish, may be declared suspended, discontinued or terminated. Failure of the Provider to maintain insurance shall not relieve the Provider from any liability under the contract, nor shall the insurance requirements be construed to conflict with the obligation of the Provider concerning indemnification.
- F. Provider shall maintain a current copy of all annual insurance policies and agrees to provide a certificate of insurance to the Parish on an annual basis or as may be reasonably requested for the term of the contract or any required Extended Reporting Period. Provider further shall ensure that all insurance policies are maintained in full force and effect throughout the duration of the Project and shall provide the Parish with annual renewal certificates of insurance evidencing continued coverage, without any prompting by the Parish.
- G. It shall be the responsibility of Provider to require that these insurance requirements are met by all contractors and sub-contractors performing work for and on behalf of Provider. Provider shall further ensure the Parish is named as an additional insured on all insurance policies provided by said contractor and/or sub-contractor throughout the duration of the project.
- H. Certificates of Insurance shall be issued as follows:

**St. Tammany Parish Government
Attn: Risk Management
P O Box 628
Covington, LA 70434**

To avoid contract processing delays, be certain the project name/number is included on all correspondence including Certificates of Insurance.

***NOTICE: St. Tammany Parish Government reserves the rights to remove, replace, make additions to and/or modify any and all of the insurance requirements at any time.**

Any inquiry regarding these insurance requirements should be addressed to:

**St. Tammany Parish Government
Office of Risk Management
P O Box 628
Covington, LA 70434
Telephone: 985-898-5226
Email: riskman@stpgov.org**

Section 07

Project Signs

1. General

- a. Work to include providing and installing project sign(s) at the beginning of the project. Some projects may require multiple signs. Should more than one sign be required, it will be reflected in the bidding documents.

2. Materials

- a. The printed project sign(s) shall be 3/8" primed Medium Density Overlay (MDO) **OR** 3-millimeter corrugated plastic secured to exterior plywood (4' x 4').
- b. Contractor shall not use previously provided templates and/or fonts.

3. Execution

- a. The sign(s) shall be printed on a project-by-project basis in black and white, using the template and font provided to the Contractor by the St. Tammany Parish Government Project Manager.
- b. All signage proofed and approved by State Tammany Parish Government before project sign(s) are to be produced by the Contractor.
- c. Exact placement of the project sign(s) must be coordinated with, and approved by, the St. Tammany Parish Government Project Manager prior to sign installation.
- d. The sign(s) is to be installed such that the bottom of the sign is a minimum of 5' above the existing ground elevation.
- e. Sign(s) is to be maintained throughout the period of construction. If sign(s) is damaged or destroyed, repair and/or replacement of sign(s) will be at Contractor's expense.
- f. Contractor is responsible for the removal of all project signs upon issuance of final acceptance by the St. Tammany Parish Government Project Manager at no direct pay.
- g. Cost to be included in "Mobilization".

Blank Template of Parish Project Sign:

PROGRESS



MICHAEL B. COOPER
Parish President

Councilmember Name
Council District X

\$XXX,XXX.XX

Total Dollar \$
amount specified here

Project Name

Description of
Project Work

Name of Street, Bridge,
Subdivision, etc. stated here

Short Description of Project stated here
(if deemed applicable by the Parish)

Example of a Completed Parish Project Sign:

PROGRESS



MICHAEL B. COOPER
Parish President

RYKERT O. TOLEDANO, JR
Council District 5

\$514,444.40

Dove Park
Subdivision Drainage
Drainage Improvements along
Swallow St., Sparrow St.,
Partridge St. and Egret St.

Section 08

General Conditions for St. Tammany Parish Government

This index is for illustrative purposes only and is not intended to be complete nor exhaustive.

All bidders/contractors are presumed to have read and understood the entire document. Some information contained in these conditions may not be applicable to all projects.

GENERAL CONDITIONS INDEX

A.A.S.H.T.O	01.01
A.C.I.	01.02
ADDENDA	01.03, 01.05, 01.12, 02.13, 02.13, 06.02, 06.03
ADVERTISEMENT	01.04, 01.12, 02.21, 02.22, 02.23
AGREEMENT	01.05, 01.11, 01.12, 01.14, 01.15, 01.19, 03.02, 03.03, 03.04, 06.01, 06.02, 10.01, 11.03, 12.01, 14.02, 29.06, 32.01, 32.02, 33.06, 33.07
APPLICATION FOR PAYMENT	01.06, 29.07
A.S.T.M.	01.07
AWARD	03.00, 03.01, 03.04, 03.05
BID	01.08, 01.12, 01.26, 02.02, 02.04, 02.08, 02.09, 02.10, 02.13, 02.14, 02.17, 02.19, 02.21, 03.01, 03.04, 04.02, 14.03, 22.01, 23.01, 28.08
BIDDER	01.04, 01.08, 01.09, 01.26, 01.28, 02.02, 02.04, 02.06, 02.08, 02.09, 02.10, 02.12, 03.13, 02.14, 02.16, 02.17, 02.19, 02.20, 02.21, 02.24, 03.01, 03.04, 03.05, 23.01
BONDS	01.10, 01.12, 02.02, 02.09, 03.00, 03.03, 03.04, 03.05, 03.07, 03.08, 03.10, 03.12, 03.13, 27.06
CHANGE ORDER	01.11, 01.19, 04.01, 09.04, 11.07, 16.02, 16.06, 16.07, 21.06, 21.08, 21.10, 21.11, 29.06, 33.07
CLAIMS	02.15, 04.05, 09.05, 14.01, 16.04, 16.05, 21.16, 24.01
CLOSING ROADS COMMENCE WORK	16.06, 16.07, 16.15 04.04, 07.04, 09.02, 11.02, 14.02, 16.13, 24.02
COMPLETION OF WORK OR PROJECT	01.14, 02.15, 08.03, 09.01, 09.04, 11.00, 11.03, 12.01, 13.01, 13.11, 20.01, 25.01, 28.02, 29.04
CONDITIONS AT JOB SITE	16.17
CONTRACT DOCUMENTS	01.03, 01.03, 01.10, 01.12, 01.13, 01.16, 01.17, 01.18, 01.19, 01.29, 01.22, 01.25, 01.30, 01.33, 02.02, 02.05, 02.13, 02.17, 02.18, 02.23, 03.01, 03.02, 04.01, 04.02, 04.03, 04.04, 04.05, 06.00, 06.01, 06.02, 06.03, 07.02, 07.03, 07.05, 08.01, 10.06, 11.03, 13.01, 13.02, 21.01, 21.09, 21.10, 21.11, 28.01, 28.04, 33.01
CONTRACT PRICE	01.11, 01.13, 03.05, 04.01, 12.01, 14.02, 21.06, 21.10, 21.11, 27.05, 28.01, 28.02, 28.03, 28.08

CONTRACT TIME	01.11, 01.14, 01.22, 10.06, 11.01, 21.06, 29.04
CONTRACTOR - (Defined)	01.15
DAMAGE	02.15, 03.05, 03.12, 04.05, 09.05, 11.09, 13.11, 14.01, 14.02, 16.01, 16.02, 16.03, 16.04, 16.05, 19.01, 19.03, 20.01, 20.08, 23.03, 24.01, 24.07, 24.12, 26.03, 28.05, 28.01, 28.10, 33.07
DEFECTIVE WORK	01.16, 10.03, 21.00, 21.01, 21.07, 21.08, 21.09, 21.10, 28.03
DELAYS	07.02, 11.05, 11.09, 12.01, 16.07, 18.02, 19.01, 28.04
DRAWINGS	01.12, 01.17, 02.13, 02.17, 02.23, 06.01, 06.02, 06.03, 13.15, 22.02, 01.27, 01.33, 03.12, 04.01, 06.02, 09.01, 10.01, 10.02, 11.07, 13.00, 13.01, 13.03, 13.05, 13.11, 13.12, 13.15, 14.02, 14.07, 14.08, 14.09, 16.09, 16.13, 21.01, 21.06, 21.07, 21.14, 24.07, 27.05, 27.07, 28.01, 28.05, 28.10, 29.03, 13.00, 13.11
ENGINEER STATUS (NOT APPLICABLE)	15.00
EXTRA WORK	03.09, 14.00, 14.03, 14.04, 14.05, 14.08, 14.09, 14.10, 14.11, 14.12, 16.01, 22.02
FAILURE OF CONTRACTOR	03.10, 04.05, 06.02, 09.05, 10.01, 10.03, 13.10, 16.03, 20.01, 24.09, 27.02, 28.10
FAILURE OF OWNER	02.13
FAILURE OF SUCCESSFUL BIDDER	02.13, 02.17, 03.04
FIELD ORDER	01.18
FORCE ACCOUNT	14.04, 14.05, 14.11, 14.12
FUNDING	33.09
INDEMNIFY / HOLD HARMLESS	02.15, 03.05, 04.05, 13.11, 16.04, 16.05, 20.02, 24.06, 24.09
INDEMNIFYING INFRINGEMENT CLAUSE	02.15
INJURIES	16.00, 16.01, 16.02, 19.01, 19.03, 20.01, 24.02, 24.07
INSPECTION FEES	13.12
INSPECTIONS, GENERALLY	01.16, 13.05, 16.13, 21.00, 21.03, 21.04, 21.05, 21.06, 21.14, 21.15, 28.04, 29.02, 29.03
INSURANCE	01.05, 14.05, 16.13, 24.00 - 12, 27.07, 28.05
INTENTION OF CONTRACT DOCUMENTS	06.00, 06.01
INTENTION OF GENERAL CONDITIONS	31.00

LABOR	01.33, 03.12, 09.01, 13.00, 13.01, 13.02, 13.08, 13.10, 13.11, 13.12, 14.05, 16.06, 16.07, 21.06, 21.07, 21.15, 27.01, 28.10, 29.03
LAWS	01.10, 01.20, 02.06, 02.13, 02.14, 02.16, 02.20, 03.01, 03.10, 13.12, 16.06, 16.07, 20.02, 21.02, 21.09, 27.01, 29.06, 33.00, 33.01, 33.08
LIQUIDATED DAMAGES	11.03, 12.00, 12.01, 29.04
MATERIALS	01.33, 03.12, 04.01, 06.02, 07.01, 09.01, 10.01, 10.02, 13.00, 13.01, 13.03, 13.04, 13.05, 13.12, 13.13, 13.15, 14.01, 14.11, 20.01, 12.01, 21.07, 21.14, 21.15, 23.03, 27.01, 27.05, 27.07, 28.01, 28.05, 28.07, 28.08, 28.10
MODIFICATIONS	01.12, 01.19, 02.12, 02.13, 06.01, 06.02, 24.07, 32.02
NOTICE OF AWARD	01.20, 03.01, 03.04, 04.01
NOTICE OF DEFAULT	12.01, 33.08
NOTICE TO BIDDER	2.21
NOTICE TO CONTRACTOR	01.12, 01.21, 21.11, 30.01
NOTICE TO OWNER	13.07, 24.06, 27.07
NOTICE TO PROCEED	01.22, 09.02, 11.01, 11.03
OBSTRUCTIONS	16.09, 16.11, 16.15, 23.00, 23.01, 23.02
OCCUPANCY	25.00
ORAL INTERPRETATIONS	02.13
OWNER - (Defined)	01.23
PAYMENT	01.30, 03.10, 03.12, 03.13, 04.12, 09.03, 11.04, 11.09, 14.04, 14.12, 16.02, 16.16, 19.02, 21.07, 21.08, 21.09, 21.10, 21.11, 21.16, 24.02, 24.03, 24.12, 27.01, 27.07, 28.00, 28.01, 28.02, 28.03, 28.04, 28.05, 28.06, 28.08, 28.09, 28.10, 29.00, 29.03, 29.05, 29.07
PERMITS	13.00, 13.12, 16.13, 28.08
PRICE	02.05, 14.02, 14.03, 14.04, 14.05, 22.01
PROGRESS PAYMENT	01.06, 28.06
PROGRESS SCHEDULE	09.03, 09.05, 21.11
PROGRESS OF WORK	09.00, 11.09, 13.07, 16.01, 16.12, 21.11, 21.12, 22.02, 27.02
PROJECT	01.24, 01.29, 01.30, 02.04, 03.07, 06.01, 07.03, 10.02, 11.04, 11.06, 13.08, 13.13, 14.08, 14.11, 16.15, 24.07, 24.11, 28.07, 29.03, 29.07

PROJECT REPRESENTATIVE	01.23, 21.16
PROPERTY	16.00, 16.01, 16.02, 16.03, 16.12, 16.13, 16.17, 18.01, 19.00, 19.01, 19.02, 19.03, 23.03, 24.01, 24.07, 26.03, 28.10, 29.08, 33.05
PROPOSAL	01.26, 02.00, 02.01, 02.03, 02.05, 02.06, 02.07, 02.08, 02.09, 02.10, 02.11, 02.12, 02.14, 02.18, 02.21, 02.22, 11.03, 12.01, 14.01, 14.02, 14.03, 19.02, 23.02, 28.08
PROTESTS	33.10
PUNCH LIST	29.03, 29.04
QUANTITIES OF ESTIMATES	14.00, 14.01, 14.02, 14.04
RAILROADS	16.13, 19.01
RECORD DRAWINGS	08.00, 18.01, 18.02, 18.03
RECORDATION OF DOCUMENTS	03.13, 28.03, 29.05, 29.06
REJECTION OF BIDS	02.03, 02.07, 02.08, 02.10, 02.14, 03.01
RENTAL OF EQUIPMENT	14.07, 14.09
RIGHTS OF WAY	18.00
SAFETY	16.01, 16.07, 16.14, 16.17
SANITARY PROVISIONS	13.01, 17.00
SCHEDULE OF WORK	09.03, 09.04, 9.05, 11.06, 13.09
SEVERABILITY	32.01, 32.02
SHOP DRAWINGS	01.27, 06.03, 07.00, 07.01, 07.02, 07.03, 07.04, 07.05
SITE	02.17, 7.04, 13.05, 13.07, 13.11, 14.06, 16.09, 21.08, 21.09, 21.12, 22.02, 23.01, 24.07
SOLICITATION OF EMPLOYMENT	13.14
SPECIFICATIONS	01.01, 01.02, 01.05, 01.07, 01.12, 01.28, 02.13, 02.17, 02.23, 03.06, 03.09, 03.10, 03.13, 06.01, 06.02, 06.03, 07.04, 07.05, 11.03, 13.05, 13.15, 20.01, 21.12, 22.02, 28.01, 28.04, 32.01
SUBCONTRACTOR	01.27, 01.29, 04.01, 04.02, 04.03, 04.04, 04.05, 16.02, 16.04, 16.05, 20.01, 20.02, 21.07, 24.01, 24.07, 27.01, 28.07
SUBCONTRACTS	04.00, 13.09
SUBSURFACE CONDITIONS	02.17, 22.00, 22.01, 22.02
SUBSTANTIAL COMPLETION	01.30, 11.04, 21.09, 28.04, 29.01, 29.02, 29.03, 29.04, 29.06
SUPERINTENDENT	01.21, 01.31, 13.07, 14.05

SUPERVISION	13.01, 13.06
SURETY	01.05, 01.10, 02.09, 03.05, 03.06, 03.07, 03.08, 03.09, 03.11, 03.12, 04.05, 05.01, 14.03, 27.03, 27.05
SURVEY	13.02, 26.00, 26.01
TAXES	02.05, 13.00, 13.12, 13.13, 14.05, 28.07, 28.08, 28.10
TERMINATION OF CONTRACT	13.10, 24.09, 27.00, 27.01, 27.02, 27.03, 27.04, 27.05, 27.06, 27.07
TESTS, GENERALLY	21.00, 21.02, 21.03, 21.04, 21.05, 21.06
TIME	01.32
TRAFFIC	16.06, 16.07, 16.10, 16.15, 16.16
TRAFFIC HAZARDS	16.16
TREES AND SHRUBS	19.02
VERBAL INSTRUCTIONS	21.16
WAIVERS	24.06, 29.03, 33.08
WARNING DEVICES	16.13, 16.14, 16.15
WARRANTY	21.01, 21.08, 21.09, 33.04, 33.06
WORK	01.31, 20.01
WORK BY OTHERS	10.03, 10.04, 10.05
WORK BY OWNER	10.02, 10.04, 10.05
WORK FOR OTHER, RESTRICTIONS	16.12
WORK ORDER	28.01

01.00 DEFINITIONS OF TERMS

Whenever used in these General Conditions or in other Contract Documents, the following terms shall have the meanings indicated, and these shall be applicable to both the singular and plural thereof.

- 01.01 A.A.S.H.T.O American Association of State Highway and Transportation Officials. When A.A.S.H.T.O. is referred to in these Specifications it takes the meaning of the specification for materials and methods of testing specified by this association and the specification stated is considered to be a part of the Specifications as if written herein in full.
- 01.02 A.C.I American Concrete Institute. When A.C.I. is referred to in these Specifications it takes the meaning of the specification for materials and methods of testing specified by this institute and the specification stated is considered to be a part of the Specifications as if written herein in full.
- 01.03 Addenda Written or graphic instruments issued prior to the opening of bids which clarify, correct, modify or change the bidding or Contract Documents.
- 01.04 Advertisement The written instrument issued by the Owner at the request of the Owner used to notify the prospective bidder of the nature of the Work. It becomes part of the Contract Documents.
- 01.05 Agreement The written agreement or contract between the Owner and the Contractor covering the Work to be performed and the price that the Owner will pay. Other documents, including the Proposal, Addenda, Specifications, plans, surety, insurance, etc., are made a part thereof.
- 01.06 Application for Payment The form furnished by the Owner which is to be used by the Contractor in requesting incremental (progress) payments and which is to include information required by Section 28.01 and an affidavit of the Contractor. The affidavit shall stipulate that progress payments theretofore received from the Owner on account of the Work have been applied by Contractor to discharge in full of all Contractor's obligations reflected in prior applications for payment.
- 01.07 A.S.T.M. American Society of Testing Materials. When A.S.T.M. is referred to in these Specifications it takes the meaning of the specification for materials and methods of testing specified by this society and the specification stated is considered to be a part of the Specifications as if written herein in full.
- 01.08 Bid The offer or Proposal of the Bidder submitted on the prescribed form setting forth all the prices for the Work to be performed.
- 01.09 Bidder Any person, partnership, firm or corporation submitting a Bid for the Work.
- 01.10 Bonds Bid, performance and payment bonds and other instruments of security, furnished by the Contractor and its surety in accordance with the Contract Documents and Louisiana law.
- 01.11 Change Order A written order to the Contractor signed by the Owner authorizing an addition, deletion or revision in the Work, or an adjustment in the Contract Price or the Contract Time after execution of the Agreement.
- 01.12 Contract Documents The Agreement, Addenda, Contractor's Bid and any documentation accompanying or post-bid documentation when attached as an exhibit, the Bonds, these General Conditions, the Advertisement for Bid, Notice to Contractor, all supplementary conditions, the Specifications, the Drawings, together with all Modifications issued after the execution of the Agreement.
- 01.13 Contract Price The total monies payable to the Contractor under the Contract Documents.

- 01.14 Contract Time The number of consecutive calendar days stated in the Agreement for the completion of the Work.
- 01.15 Contractor The person, firm, corporation or provider with whom the Owner has executed the Agreement.
- 01.16 Defective Work When work which is unsatisfactory, faulty or deficient for any reason whatsoever, or does not conform to the Contract Documents, or does not meet the requirements of any inspection, test or approval referred to in the Contract Documents, or has been damaged prior to the Owner's recommendation or acceptance.
- 01.17 Drawings The Drawings and plans which show the character and scope of the Work to be performed and which have been prepared or approved by the Owner and are referred to in the Contract Documents.
- 01.18 Field Order A written order issued by the Owner or his agent which clarifies or interprets the Contract Documents.
- 01.19 Modification (a) A written amendment of the Contract Documents signed by both parties, (b) A Change Order, (c) A written clarification or interpretation issued by the Owner or his agent. Modification may only be issued after execution of the Agreement.
- 01.20 Notice of Award The written notice by Owner to the lowest responsible Bidder stating that upon compliance of the conditions enumerated in the Notice of Award, or enumerated in the Bid documents, the Owner will deliver the Contract Documents for signature. The time for the delivery of the Contract Documents can be extended in conformance with Louisiana Law.
- 01.21 Notice to Contractor Instructions, written or oral given by Owner to Contractor and deemed served if given to the Contractor's superintendent, foreman or mailed to Contractor at his last known place of business.
- 01.22 Notice to Proceed A written notice given by the Owner fixing the date on which the Contract Time will commence, and on which date the Contractor shall start to perform his obligation under the Contract Documents. Upon mutual consent by both parties, the Notice to Proceed may be extended.
- 01.23 Owner St. Tammany Parish Government, acting herein through its duly constituted and authorized representative, including but not limited to the Office of the Parish President or its designee, its Chief Administrative Officer, and/or Legal Counsel. St. Tammany Parish Government (hereinafter, the "Parish") and Owner may be used interchangeably.
- 01.24 Project The entire construction to be performed as provided in the Contract Documents.
- 01.25 Project Representative The authorized representative of the Owner who is assigned to the Project or any parts thereof.
- 01.26 Proposal The Bid submitted by the Bidder to the Owner on the Proposal form setting forth the Work to be done and the price for which the Bidder agrees to perform the Work.
- 01.27 Shop Drawings All drawings, diagrams, illustrations, brochures, schedules and other data which are prepared by the Contractor, Subcontractor, Manufacturer, Supplier or Distributor and which illustrate the equipment, material or some portion of the Work.
- 01.28 Specifications The Instructions to Bidders, these General Conditions, the Special Conditions and the Technical Provisions. All of the documents listed in the "Table of Contents."
- 01.29 Subcontractor An individual, firm or corporation having a direct Contract with the Contractor or with any other Subcontractor for the performance of a part of the Project Work.
- 01.30 Substantial Completion The date as certified by the Owner or its agent when the construction of the Project or a specified part thereof is sufficiently complete in accordance with the Contract Documents so that the Project or specified part can be utilized for the

purposes for which it was intended; or if there is no such certification, the date when final payment is due in accordance with Section 28.

- 01.31 Superintendent Contractor's site representative. The person on the site who is in full and complete charge of the Work.
- 01.32 Time Unless specifically stated otherwise, all time delays shall be calculated in calendar days.
- 01.33 Work Any and all obligations, duties and responsibilities necessary to the successful completion of the Project assigned to or undertaken by the Contractor under the Contract Documents, usually including the furnishing of all labor, materials, equipment and other incidentals.
- 01.34 The terms "he/himself" may be used interchangeably with "it/itself."

02.00 PROPOSAL

- 02.01 All papers bound with or attached to the Proposal Form are a necessary part thereof and must not be detached.
- 02.02 For submitting Bids, the only forms allowed shall be the "Louisiana Uniform Public Work Bid Form", "Louisiana Uniform Public Works Bid Form Unit Price Form" (if necessary), the Bid Bond, and written evidence of authority of person signing the bid. Necessary copies of the Louisiana Uniform Public Work Forms will be furnished for Bidding. Bound sets of the Contract Documents are for Bidder's information and should not be used in submitting Bids.
- 02.03 Proposal forms must be printed in ink or typed, unless submitted electronically. Illegibility or ambiguity therein may constitute justification for rejection of the Bid.
- 02.04 Each Bid must be submitted in a sealed envelope, unless submitted electronically. The outside of the envelope shall show the name and address of the Bidder, the State Contractor's License Number of the Bidder (if work requires contractor's license), and the Project name and number for which the Bid is submitted, along with the Bid number.
- 02.05 The price quoted for the Work shall be stated in words and figures on the Bid Form, and in numbers only on the Unit Price Form. The price in the Proposal shall include all costs necessary for the complete performance of the Work in full conformity with the conditions of the Contract Documents, and shall include all applicable Federal, State, Parish, Municipal or other taxes. The price bid for the items listed on the Unit Price Form will include the cost of all related items not listed, but which are normally required to do the type of Work bid.
- 02.06 The Bid shall be signed by the Bidder. The information required on the Louisiana Uniform Public Work Bid Form must be provided. Evidence of agency, corporate, or partnership authority is required and shall be provided in conformance with LSA-R.S. 38:2212(B).
- 02.07 Only the Contractors licensed by the State to do the type of Work involved can submit a Proposal for the Work. The envelope containing the Proposal shall have the Contractor's license number on it. Failure to be properly licensed constitutes authority by the Owner for rejection of Bid.
- 02.08 Bidders shall not attach any conditions or provisions to the Proposal. Any conditions or provisions so attached may, at the sole option of the Owner, cause rejection of the Bid or Proposal.
- 02.09 A Bid Guarantee of five percent (5%) of the amount of the total Bid, including Alternates, must accompany the Proposal and, at the option of the Bidder, may be a cashier's check, certified check or a satisfactory Bid Bond. The Bid Guarantee must be attached to the Louisiana Uniform Public Work Bid Form. No Bid will be considered unless it is so guaranteed. Cashier's check or certified check must be made payable to the order of the Owner. Cash deposits will not be accepted. The Owner reserves the right to cash or deposit the cashier's check or certified check. Such guarantees shall be made payable to the Parish

of St. Tammany. In accordance with LSA-R.S. 38:2218(C), if a bid bond is used, it shall be written by a surety or insurance company currently on the U.S. Department of the Treasury Financial Management Service list of approved bonding companies which is published annually in the Federal Register, or by a Louisiana domiciled insurance company with at least an A- rating in the latest printing of the A.M. Best's Key Rating Guide to write individual bonds up to ten percent of policyholders' surplus as shown in the A.M. Best's Key Rating Guide, or by an insurance company in good standing licensed to write bid bonds which is either domiciled in Louisiana or owned by Louisiana residents. It is **not** required to be on any AIA form.

- 02.10 Bid securities of the three (3) lowest Bidders will be retained by the Owner until the Contract is executed or until final disposition is made of the Bids submitted. Bid securities of all other Bidders will be returned promptly after the canvas of Bids. Bids shall remain binding for forty-five (45) days after the date set for Bid Opening. The Parish shall act within the forty-five (45) days to award the contract to the lowest responsible bidder or reject all bids as permitted by Public Bid Law. However, the Parish and the lowest responsible bidder, by mutual written consent, may agree to extend the deadline for award by one or more extensions of thirty (30) calendar days. In the event the Owner issued the Letter of Award during this period, or any extension thereof, the Bid accepted shall continue to remain binding until the Execution of the Contract.
- 02.11 A Proposal may be withdrawn at any time prior to the scheduled closing time for receipt of Bids, provided the request is in writing, executed by the Bidder or its duly authorized representative and is filed with the Owner prior to that time. When such a request is received, the Proposal will be returned to the Bidder unopened.
- 02.12 Written communications, over the signature of the Bidder, to modify Proposals will be accepted and the Proposal corrected in accordance therewith if received by the Owner prior to the scheduled closing time for receipt of Bids. Oral, telephonic or telegraphic Modifications will not be considered.
- 02.13 No oral interpretation obligating the Owner will be made to any Bidder as to the meaning of the Drawings, Specifications and Contract Documents. Every request for such an interpretation shall be made in writing and addressed and forwarded to the Owner. No inquiry received within seven (7) days prior to the day fixed for opening of the Bids shall be given consideration. Every interpretation made to the Bidder shall be in the form of an addendum to the Specifications. All such Addenda shall become part of the Contract Documents. Failure of Bidder to receive any such interpretation shall not relieve any Bidder from any obligation under this Bid. All Addenda shall be issued in accordance with the Public Bid Law, LSA-R.S. 38:2212(O)(2)(a) and (b).
- 02.14 The Owner reserves the right to reject any or all Bids for just cause in accordance with the Public Bid Law, LSA-R.S. 38:2214(B). Incomplete, informal or unbalanced Bids may be rejected. Reasonable grounds for belief that any one Bidder is concerned directly or indirectly with more than one Bid will cause rejection of all Bids wherein such Bidder is concerned. If required, a Bidder shall furnish satisfactory evidence of its competence and ability to perform the Work stipulated in its Proposal. Incompetence will constitute cause for rejection. If the Parish determines that the bidder is not responsive or responsible for any reason whatsoever, the bid may be rejected in accordance with State law.
- 02.15 The Contractor shall indemnify and hold harmless the Owner from any and all suits, costs, penalties or claims for infringement by reason of use or installation of any patented design, device, material or process, or any trademark and copyright in connection with the Work agreed to be performed under this Contract, and shall indemnify and hold harmless the Owner for any costs, expenses and damages which it may be obliged to pay by reason of any such infringement at any time during the prosecution or after completion of the Work.
- 02.16 Bidders shall familiarize themselves with and shall comply with all applicable Federal and State Laws, municipal ordinances and the rules and regulations of all authorities having jurisdiction over construction of the Project, which may directly or indirectly affect the Work or its prosecution. These laws and/or ordinances will be deemed to be included in the Contract, as though herein written in full.
- 02.17 Each Bidder shall visit the site of the proposed Work and fully acquaint itself with all surface and subsurface conditions as they may exist so that it may fully understand this

Contract. Bidder shall also thoroughly examine and be familiar with drawings, Specifications and Contract Documents. The failure or omission of any Bidder to receive or examine any form instrument, Drawing or document or to visit the site and acquaint itself with existing conditions, shall in no way relieve any Bidder from any obligation with respect to its Bid and the responsibility in the premises.

- 02.18 The standard contract form enclosed with the Proposal documents is a prototype. It is enclosed with the Contract Documents for the guidance of the Owner and the Contractor. It has important legal consequences in all respects and consultation with an attorney is encouraged. Contractor shall be presumed to have consulted with its own independent legal counsel.
- 02.19 When one set of Contract plans show the Work to be performed by two or more prime Contractors, it is the responsibility of each Bidder to become knowledgeable of the Work to be performed by the other where the Work upon which this bid is submitted is shown to come into close proximity or into conflict with the Work of the other. In avoiding conflicts, pressure pipe lines must be installed to avoid conflict with gravity pipe lines and the Bidder of the smaller gravity pipe line in conflict with the larger gravity pipe line must include in his Bid the cost of a conflict box at these locations. The location of and a solution to the conflicts do not have to be specifically noted as such on the plans.
- 02.20 Bidder shall execute affidavit(s) attesting compliance with LSA-R.S. 38:2212.10, 38:2224, 38:2227, each as amended, and other affidavits as required by law, prior to execution of the contract.
- 02.21 Sealed Proposals (Bid) shall be received by St. Tammany Parish Government at the office of St. Tammany Parish Government, Department of Procurement, 21454 Koop Drive, Suite 2-F, Mandeville, LA 70471, until the time and date denoted in Notice to Bidders, at which time and place the Proposals (Bids), shall be publicly opened and read aloud to those present. In accordance with LSA-R.S. 38-2212(A)(3)(c)(i), the designer's final estimated cost of construction shall be read aloud upon opening bids. Sealed Proposals (Bids) may also be mailed by certified mail to St. Tammany Parish Government, Department of Procurement, 21454 Koop Drive, Suite 2-F, Mandeville, LA 70471, and must be received before the bid opening. Bids may also be submitted electronically. Information concerning links for electronic bidding is contained in the Notice to Bidders.
- 02.22 Proposals (Bids) shall be executed on Forms furnished and placed in a sealed envelope, marked plainly and prominently as indicated in the Notice to Bidders, and these General Conditions, and addressed:

St. Tammany Parish Government
Department of Procurement
21454 Koop Drive, Suite 2-F
Mandeville, LA 70471

- 02.23 See Notice to Bidders for availability of Drawings, Specifications and Contract Documents via electronic methods.
- 02.24 The successful Bidder shall be required to post in each direction a public information sign, 4' x 4' in size, at the location of the project containing information required by the Owner. The Owner shall supply this information.

03.00 AWARD, EXECUTION OF DOCUMENTS, BONDS, ETC.

- 03.01 The award of the Contract, if it is awarded, will be to the lowest responsible Bidder, in accordance with State Law. No award will be made until the Owner has concluded such investigations as it deems necessary to establish the responsibility, qualifications and financial ability and stability of the Bidder to do the Work in accordance with the Contract Documents to the satisfaction of the Owner within the time prescribed as established by the Department based upon the amount of work to be performed and the conditions of same. The written contract and bond shall be issued in conformance with LSA-R.S. 38:2216. The Owner reserves the right to reject the Bid of any Bidder in accordance with the Public Bid Law, LSA-R.S. 38:2214. If the Contract is awarded, the Owner shall give the successful Bidder written notice of the award within forty-five (45) calendar days after

the opening of the Bids in conformance with LSA-R.S. 38:2215(A), or any extension as authorized thereunder.

- 03.02 At least three counterparts of the Agreement and of such other Contract Documents as practicable shall be signed by the Owner and the Contractor. The Owner shall identify those portions of the Contract Documents not so signed and such identification shall be binding on both parties. The Owner and the Contractor shall each receive an executed counterpart of the Contract Documents.
- 03.03 Prior to the execution of the Agreement, the Contractor shall deliver to the Owner the required Bonds.
- 03.04 Failure of the successful Bidder to execute the Agreement and deliver the required Bonds within twenty (20) days of the Notice of the Award shall be just cause for the Owner to annul the award and declare the Bid and any guarantee thereof forfeited.
- 03.05 In order to ensure the faithful performance of each and every condition, stipulation and requirement of the Contract and to indemnify and save harmless the Owner from any and all damages, either directly or indirectly arising out of any failure to perform same, the successful Bidder to whom the Contract is awarded shall furnish a surety Bond in an amount of at least equal to one hundred percent (100%) of the Contract Price. The Contract shall not be in force or binding upon the Owner until such satisfactory Bond has been provided to and approved by the Parish. The cost of the Bond shall be paid for by the Contractor unless otherwise stipulated in the Special Provisions.
- 03.06 No surety Company will be accepted as a bondsman who has no permanent agent or representative in the State upon whom notices referred to in the General Conditions of these Specifications may be served. Services of said notice on said agent or representative in the State shall be equal to service of notice on the President of the Surety Company, or such other officer as may be concerned.
- 03.07 In conformance with LSA-R.S. 38:2219(A)(1)(a), (b), and (c):

Any surety bond written for a public works project shall be written by a surety or insurance company currently on the U.S. Department of the Treasury Financial Management Service list of approved bonding companies which is published annually in the Federal Register, or by a Louisiana domiciled insurance company with at least an A- rating in the latest printing of the A.M. Best's Key Rating Guide, to write individual bonds up to ten percent of policyholders' surplus as shown in the A.M. Best's Key Rating Guide or by an insurance company that is either domiciled in Louisiana or owned by Louisiana residents and is licensed to write surety bonds.

For any public works project, no surety or insurance company shall write a bond which is in excess of the amount indicated as approved by the U.S. Department of the Treasury Financial Management Service list or by a Louisiana domiciled insurance company with an A- rating by A.M. Best up to a limit of ten percent of policyholders' surplus as shown by A.M. Best; companies authorized by this Paragraph who are not on the treasury list shall not write a bond when the penalty exceeds fifteen percent of its capital and surplus, such capital and surplus being the amount by which the company's assets exceed its liabilities as reflected by the most recent financial statements filed by the company with the Department of Insurance.

In addition, any surety bond written for a public works project shall be written by a surety or insurance company that is currently licensed to do business in the state of Louisiana. All contractors must comply with any other applicable provisions of LSA-R.S. 38:2219.

- 03.08 Should the Contractor's Surety, even though approved and accepted by the Owner, subsequently remove its agency or representative from the State or become insolvent, bankrupt, or otherwise fail, the Contractor shall immediately furnish a new Bond in another company approved by the Owner, at no cost to the Owner. The new Bond shall be executed under the same terms and conditions as the original Bond. The new bond shall be submitted within thirty (30) days of such time as the Owner notifies Contractor or from the time Contractor learns or has reason to know that the original surety is no longer financially viable or acceptable to the Parish, whichever occurs first. In the event that Contractor fails

or refuses to timely secure additional surety, then the Owner may secure such surety and thereafter deduct such cost or expense from any sum due or to become due Contractor.

- 03.09 The Contractor's bondsman shall obligate itself to all the terms and covenants of these Specifications and of contracts covering the Work executed hereunder. The Owner reserves the right to do Extra Work or make changes by altering, adding to deducting from the Work under the conditions and in the manner herein before described without notice to the Contractor's surety and without in any manner affecting the liability of bondsman or releasing it from any of its obligations hereunder.
- 03.10 The Bond shall also secure for the Owner the faithful performance of the Contract in strict accordance with plans and Specifications. It shall protect the Owner against all lien laws of the State and shall provide for payment of reasonable attorney fees for enforcement of Contract and institution or concursus proceedings, if such proceedings become necessary. Likewise, it shall provide for all additional expenses of the Owner occurring through failure of the Contractor to perform.
- 03.11 The surety of the Contractor shall be and does hereby declare and acknowledge itself by acceptance to be bound to the Owner as a guarantor, jointly and in solido, with the Contractor, for fulfillment of terms of Section 03.00.
- 03.12 The performance Bond and Labor and Material Bond forming part of this Contract shall be continued by Contractor and its Surety for a period of one (1) year from date of acceptance of this Contract by Owner to assure prompt removal and replacement of all defective material, equipment, components thereof, workmanship, etc., and to assure payment of any damage to property of Owner or others as a result of such defective materials, equipment, workmanship, etc.
- 03.13 Contractor shall pay for the cost of recording the Contract and Bond and the cost of canceling same. Contractor shall also secure and pay for all Clear Lien and Privilege Certificates (together with any updates) which will be required before any final payment is made, and that may be required before any payment, at the request of the Owner, its representative, agent, architect, engineer and the like. All recordation and Clear Lien and Privilege Certificate requirements shall be in accordance with those requirements noted herein before in contract Specifications.

04.00 SUBCONTRACTS

- 04.01 Contractor shall be fully responsible for all acts and omissions of its Subcontractors and of persons and organizations for whose acts any of them may be liable to the same extent that it is responsible for the acts and omissions of persons directly employed by it. Nothing in the Contract Documents shall create any contractual relationship between Owner and any Subcontractor or other person or organization having a direct Contract with Contractor, nor shall it create any obligation on the part of the Owner to pay or to see to the payment of any monies due any Subcontractor.
- 04.02 Nothing in the Contract Documents shall be construed to control the Contractor in dividing the Work among approved Subcontractors or delineating the Work to be performed by any trade.
- 04.03 The Contractor agrees to specifically bind every Subcontractor to all of the applicable terms and conditions of the Contract Documents prior to commencing Work. Every Subcontractor, by undertaking to perform any of the Work, shall thereby automatically be deemed bound by such terms and conditions.
- 04.04 The Contractor shall indemnify and hold harmless the Owner and their agents and employees from and against all claims, damages, losses and expenses including Attorney's fees arising out of or resulting from the Contractor's failure to bind every Subcontractor and Contractor's surety to all of the applicable terms and conditions of the Contract Documents.

05.00 ASSIGNMENT

05.01 Neither party to this Contract shall assign or sublet its interest in this Contract without prior written consent of the other, nor shall the Contractor assign any monies due or to become due to it under this Contract without previous written consent of the Owner, nor without the consent of the surety unless the surety has waived its right to notice of assignment.

06.00 CORRELATION, INTERPRETATION AND INTENT OF CONTRACT DOCUMENTS.

06.01 It is the intent of the Specifications and Drawings to describe a complete Project to be constructed in accordance with the Contract Documents. The Contract Documents comprise the entire Agreement between Owner and Contractor. Alterations, modifications and amendments shall only be in writing between these parties.

06.02 The Contract Documents are intended to be complimentary and to be read *in pari materii*, and what is called for by one is as binding as if called for by all. If Contractor finds a conflict, error or discrepancy in the Contract Documents, it shall call it to the Owner's attention, in writing, at once and before proceeding with the Work affected thereby; however, it shall be liable to Owner for its failure to discover any conflict, error or discrepancy in the Specifications or Drawings. In resolving such conflicts, errors and discrepancies, the documents shall be given precedence in the following order: Agreement, Modifications, Addenda, Special Conditions, General Conditions, Construction Specifications and Drawings. The general notes on the plans shall be considered special provisions. Figure dimensions on Drawings shall govern over scale dimensions and detail Drawings shall govern over general Drawings. Where sewer connections are shown to fall on a lot line between two lots, the Contractor shall determine this location by measurement not by scale. Any Work that may reasonably be inferred from the Specifications or Drawings as being required to produce the intended result shall be supplied whether or not it is specifically called for. Work, materials or equipment described herein which so applied to this Project are covered by a well-known technical meaning or specification shall be deemed to be governed by such recognized standards unless specifically excluded.

06.03 Unless otherwise provided in the Contract Documents, the Owner will furnish to the Contractor (free of charge not to exceed ten (10) copies) Drawings and Specifications for the execution of Work. The Drawings and Specifications are the property of the Owner and are to be returned to it when the purpose for which they are intended have been served. The Contractor shall keep one copy of all Drawings and Specifications, including revisions, Addenda, details, Shop Drawings, etc. on the Work in good order and available to the Owner or the regulatory agency of the governmental body having jurisdiction in the area of the Work.

07.00 SHOP DRAWINGS, BROCHURES AND SAMPLES

07.01 After checking and verifying all field measurements, Contractor shall submit to Owner for approval, five copies (or at Owner's option, one reproducible copy) of all Shop Drawings, which shall have been checked by and stamped with the approval of Contractor and identified as Owner may require. The data shown on the Shop Drawings will be complete with respect to dimensions, design criteria, materials of construction and the like to enable Owner to review the information as required.

07.02 Contractor shall also submit to Owner, for review with such promptness as to cause no delay in Work, all samples as required by the Contract Documents. All samples will have been checked by and stamped with the approval of Contractor identified clearly as to material, manufacturer, any pertinent catalog numbers and the use for which intended. At the time of each submission, Contractor shall in writing call Owner's attention to any deviations that the Shop Drawings or samples may have from the requirements of the Contract Documents.

07.03 Owner will review with reasonable promptness Shop Drawings and samples, but its review shall be only for conformance with the design concept of the Project and for compliance with the information given in the Contract Documents. The review of a separate item as such will not indicate approval of the assembly in which the item functions. Contractor shall make any corrections required by Owner and shall return the required number of

corrected copies of Shop Drawings and resubmit new samples for review. Contractor shall direct specific attention in writing or on resubmitted Shop Drawings to revisions other than the corrections called for by Owner on previous submissions. Contractor's stamp of approval on any Shop Drawing or sample shall constitute a representation to Owner that Contractor has determined and verified all quantities, dimensions, field construction criteria, materials catalog numbers and similar data and thereafter assumes full responsibility for doing so, and that it has reviewed or coordinated each Shop Drawing or sample with the requirements of the Work and the Contract Documents.

07.04 Where a Shop Drawing or sample submission is required by the Specifications, no related Work shall be commenced until the submission has been reviewed by Owner. A copy of each reviewed shop Drawing and each inspected sample shall be kept in good order by Contractor at the site and shall be available to Owner.

07.05 Owner's review of Shop Drawings or samples shall not relieve Contractor from its responsibility for any deviations from the requirements of the Contract Documents unless Contractor has in writing called Owner's attention to such deviation at the time of submission and Owner has given written approval to the specific deviation, nor shall any review by Owner relieve Contractor from responsibility for errors or omissions in the Shop Drawings. The mere submittal of shop drawings which contain deviations from the requirements of plans, specifications and/or previous submittals in itself does not satisfy this requirement.

08.00 RECORD DRAWINGS

08.01 The Contractor shall keep an accurate record in a manner approved by the Owner of all changes in the Contract Documents during construction. In Work concerning underground utilities, the Contractor shall keep an accurate record in a manner approved by the Owner of all valves, fittings, etc. Before the Work is accepted by the Owner, and said acceptance is recorded, the Contractor shall furnish the Owner a copy of this record.

08.02 Contractor shall keep an accurate drawing measured in the field to the nearest 0.1' of the location of all sewer house connections. The location shown shall be the end of the connection at the property line measured along the main line of pipe from a manhole.

08.03 Contractor shall keep an accurate drawing of the storm water drainage collection system. Inverts to the nearest 0.01' and top of castings shall be shown as well as location of all structures to the nearest 0.1'. Upon completion of the Work, the plan will be given to the Owner.

09.00 PROGRESS OF WORK

09.01 Contractor shall conduct the Work in such a professional manner and with sufficient materials, equipment and labor as is considered necessary to ensure its completion within the time limit specified.

09.02 The Owner shall issue a Notice to Proceed to the Contractor within twenty (20) calendar days from the date of execution of the Contract. Upon mutual consent by both parties, the Notice to Proceed may be extended. The Contractor is to commence Work under the Contract within ten (10) calendar days from the date the Notice to Proceed is issued by the Owner.

09.03 The Contractor, immediately after being awarded the Contract, shall prepare and submit for the Owner's approval an estimated progress schedule for the work to be performed, as well as a construction signing layout for all roads within the project area. The Contractor shall not start work or request partial payment until the work schedule has been submitted to the Owner for approval.

09.04 Revisions to the original schedule will be made based on extension of days granted for inclement weather or change orders issued under the contract. No other revision shall be made which affects the original completion or updated completion date, whichever is applicable.

09.05 Failure of the Contractor to submit an estimated progress schedule or to complete timely and on schedule the Work shown on the progress schedule negates any and all causes or claims by the Contractor for accelerated completion damages. These accelerated damage claims shall be deemed forfeited.

09.06 Meetings will be held as often as necessary to expedite the progress of the job. Meetings will be held during normal working hours at the jobsite and shall be mandatory for the Contractor and all Sub-Contractors working on the project. Meetings may be requested by the Owner at any time and at the discretion of the Owner.

10.00 OWNER'S RIGHT TO PROCEED WITH PORTIONS OF THE WORK

10.01 Upon failure of the Contractor to comply with any notice given in accordance with the provisions hereof, the Owner shall have the alternative right, instead of assuming charge of the entire Work, to place additional forces, tools, equipment and materials on parts of the Work. The cost incurred by the Owner in carrying on such parts of the Work shall be payable by the Contractor. Such Work shall be deemed to be carried on by the Owner on account of the Contractor. The Owner may retain all amounts of the cost of such Work from any sum due Contractor or those funds that may become due to Contractor under this Agreement.

10.02 Owner may perform additional Work related to the Project by itself or it may let any other direct contract which may contain similar General Conditions. Contractor shall afford the other contractors who are parties to such different contracts (or Owner, if it is performing the additional Work itself) reasonable opportunity for the introduction and storage of materials and equipment and the execution of Work, and shall properly connect and coordinate its Work with the subsequent work.

10.03 If any part of Contractor's Work depends upon proper execution or results upon the Work of any such other contractor (or Owner), Contractor shall inspect and promptly report to Owner in writing any defects or deficiencies in such Work that render it unsuitable for such proper execution and results. Failure to so report shall constitute an acceptance of the other Work as fit and proper for the relationship of its Work except as to defects and deficiencies which may appear in the other Work after the execution of its Work.

10.04 Whatever Work is being done by the Owner, other Contractors or by this Contractor, the parties shall respect the various interests of the other parties at all times. The Owner may, at its sole discretion, establish additional rules and regulations concerning such orderly respect of the rights of various interests.

10.05 Contractor shall do all cutting, fitting and patching of its Work that may be required to integrate its several parts properly and fit to receive or be received by such other Work. Contractor shall not endanger any Work of others by cutting, excavating or otherwise altering Work and will only alter Work with the written consent of Owner and of the other contractors whose Work will be affected.

10.06 If the performance of additional Work by other contractors or Owner is not noted in the Contract Documents, written notice thereof shall be given to Contractor prior to starting any such additional Work. If Contractor believes that the performance of such additional Work by Owner or others may cause additional expense or entitles an extension of the Contract Time, the Contractor may make a claim therefor. The claim must be in writing to the Owner within thirty (30) calendar days of receipt of notice from the Owner of the planned additional Work by others.

11.00 TIME OF COMPLETION

11.01 The Notice to Proceed will stipulate the date on which the Contractor shall begin work. That date shall be the beginning of the Contract Time charges.

11.02 Contractor shall notify the Owner through its duly authorized representative, in advance, of where Contractor's work shall commence each day. A daily log shall be maintained by Contractor to establish dates, times, persons contacted, and location of work. Specific notice shall be made to the Owner if the Contractor plans to work on Saturday, Sunday, or

a Parish approved holiday. If notice is not received, no consideration will be given for inclement weather and same shall be considered a valid work day.

- 11.03 The Work covered by the Plans, Specifications and Contract Documents must be completed sufficiently for acceptance within the number of calendar days specified in the Proposal and/or the Contract, commencing from the date specified in the Notice to Proceed. It is hereby understood and mutually agreed, by and between the Contractor and the Owner, that the time of completion is an essential condition of this Contract, and it is further mutually understood and agreed that if the Contractor shall neglect, fail or refuse to complete the Work within the time specified, or any proper extension thereof granted by the Owner, then the Contractor does hereby agree, as partial consideration for the awarding of this Contract, to pay the Owner based on **Table 3.1** as specified in the Contract, not as a penalty, but as liquidated damages for such breach of contract for each and every calendar day that the Contractor shall be in default after the time stipulated in the Contract for completing the Work. It is specifically understood that the Owner shall also be entitled to receive a reasonable attorney fee and all costs in the event that Contractor fails to adhere to this agreement and this contract is referred to counsel for any reason whatsoever. Reasonable attorney fees shall be the prevailing hourly rate of the private sector, and in no event shall the hourly rate be less than \$175.00 per hour. All attorney fees shall be paid to the operating budget of the Office of the Parish President.
- 11.04 Prior to final payment, the Contractor may, in writing to the Owner, certify that the entire Project is substantially complete and request that the Owner or its agent issue a certificate of Substantial Completion. See Section 29.00.
- 11.05 The Owner may grant an extension(s) of time to the Contractor for unusual circumstances which are beyond the control of the Contractor and could not reasonably be foreseen by the Contractor prior to Bidding. Any such request must be made in writing to the Owner within seven (7) calendar days following the event occasioning the delay. The Owner shall have the exclusive and unilateral authority to determine, grant, and/or deny the validity of any such claim.
- 11.06 Extensions of time for inclement weather shall be processed as follows:

Commencing on the start date of each job, the Parish Inspector assigned to same shall keep a weekly log, indicating on each day whether inclement weather has prohibited the Contractor from working on any project within the specific job, based upon the following:

1. Should the Contractor prepare to begin work on any day in which inclement weather, or the conditions resulting from the weather, prevent work from beginning at the usual starting time, and the crew is dismissed as a result, the Contractor will not be charged for a working day whether or not conditions change during the day and the rest of the day becomes suitable for work.
2. If weather conditions on the previous day prevent Contractor from performing work scheduled, provided that no other work can be performed on any project within the package. The Parish Inspector shall determine if it is financially reasonable to require the Contractor to deviate from the schedule and relocate to another location.
3. If the Contractor is unable to work at least 60% of the normal work day due to inclement weather, provided that a normal working force is engaged on the job.

Any dispute of weather conditions as related to a specific job shall be settled by records of the National Weather Service.

- 11.07 Extensions of time for change orders

When a change order is issued, the Owner and Contractor will agree on a reasonable time extension, if any, to implement such change. Consideration shall be given for, but not limited to, the following:

1. If material has to be ordered;
2. Remobilization and or relocation of equipment to perform task; and
3. Reasonable time frame to complete additional work.

Time extensions for change orders shall be reflected on the official document signed by the Owner and Contractor.

- 11.08 At the end of each month, the Owner or its agent will furnish to the Contractor a monthly statement which reflects the number of approved days added to the contract. The Contractor will be allowed fourteen (14) calendar days in which to file a written protest setting forth in what respect the monthly statement is incorrect; otherwise, the statement shall be considered accepted by the Contractor as correct.
- 11.09 Apart from extension of time for unavoidable delays, no payment or allowance of any kind shall be made to the Contractor as compensation for damages because of hindrance or delay for any cause in the progress of the Work, whether such delay be avoidable or unavoidable.

12.00 LIQUIDATED DAMAGES

- 12.01 In case the Work is not completed in every respect within the time that may be extended, it is understood and agreed that per diem deductions per **Table 3.1** for liquidated damages, as stipulated in the Proposal and/or Contract, shall be made from the total Contract Price for each and every calendar day after and exclusive of the day on which completion was required, and up to the completion of the Work and acceptance thereof by the Owner. It is understood and agreed that time is of the essence to this Contract, and the above sum being specifically herein agreed upon in advance as the measure of damages to the Owner on account of such delay in the completion of the Work. It is further agreed that the expiration of the term herein assigned or as may be extended for performing the Work shall, *ipso facto*, constitute a putting in default, the Contractor hereby waiving any and all notice of default. The Contractor agrees and consents that the Contract Price, reduced by the aggregate of the entire damages so deducted, shall be accepted in full satisfaction of all Work executed under this Contract. It is further understood and agreed that Contractor shall be liable for a reasonable attorney fee and all costs associated with any breach of this agreement, including but not limited to this subsection. In the event that any dispute or breach herein causes referrals to counsel, then Contractor agrees to pay a reasonable attorney fee at the prevailing hourly rate of the private sector. In no event shall the hourly rate be less than \$175.00 per hour.

13.00 LABOR, MATERIALS, EQUIPMENT, SUPERVISION, PERMITS AND TAXES

- 13.01 The Contractor shall provide and pay for all labor, materials, equipment, supervision, subcontracting, transportation, tools, fuel, power, water, sanitary facilities and all incidentals necessary for the completion of the Work in substantial conformance with the Contract Documents.
- 13.02 The Contractor shall provide competent, suitably qualified personnel to survey and lay out the Work and perform construction as required by the Contract Documents. It shall at all times maintain good discipline and order at the site.
- 13.03 Unless otherwise specifically provided for in the Specifications, all workmanship, equipment, materials, and articles incorporated in the Work covered by this Contract are to be new and of the best grade of their respective kinds for the purpose intended. Samples of materials furnished under this Contract shall be submitted for approval to the Owner when and as directed.
- 13.04 Whenever a material or article required is specified or shown on the plans by using the name of a proprietary product or of a particular manufacturer or vendor, any material or article which shall perform adequately the duties imposed by the general design will be considered equal, and satisfactory, providing the material or article so proposed is of equal substance and function and that all technical data concerning the proposed substitution be approved by the Owner prior to the Bidding. The Owner shall have the exclusive and unilateral discretion to determine quality and suitability in accordance with LSA-R.S. 38:2212(T)(2).

- 13.05 Materials shall be properly and securely stored so as to ensure the preservation of quality and fitness for the Work, and in a manner that leaves the material accessible to inspection. Materials or equipment may not be stored on the site in a manner such that it will interfere with the continued operation of streets and driveways or other contractors working on the site.
- 13.06 The Contractor, by entering into the Contract for this Work, sets itself forth as an expert in the field of construction and it shall supervise and direct the Work efficiently and with its best skill and attention. It shall be solely responsible for the means, methods, techniques, sequences and procedures of construction.
- 13.07 Contractor shall keep on the Work, at all times during its progress, a competent resident Superintendent, who shall not be replaced without written Notice to Owner except under extraordinary circumstances. The Superintendent will be Contractor's representative at the site and shall have authority to act on behalf of Contractor. All communications given to the Superintendent shall be as binding as if given to the Contractor. Owner specifically reserves the right to approve and/or disapprove the retention of a new superintendent, all to not be unreasonably withheld.
- 13.08 Any foreman or workman employed on this Project who disregards orders or instructions, does not perform his Work in a proper and skillful manner, or is otherwise objectionable, shall, at the written request of the Owner, be removed from the Work and shall be replaced by a suitable foreman or workman.
- 13.09 The Contractor and/or its assigned representative shall personally ensure that all subcontracts and divisions of the Work are executed in a proper and workmanlike manner, on scheduled time, and with due and proper cooperation.
- 13.10 Failure of the Contractor to keep the necessary qualified personnel on the Work shall be considered cause for termination of the Contract by the Owner.
- 13.11 Only equipment in good working order and suitable for the type of Work involved shall be brought onto the job and used by the Contractor. The Contractor is solely responsible for the proper maintenance and use of its equipment and shall hold the Owner harmless from any damages or suits for damages arising out of the improper selection or use of equipment. No piece of equipment necessary for the completion of the Work shall be removed from the job site without approval of the Owner.
- 13.12 All Federal, State and local taxes due or payable during the time of Contract on materials, equipment, labor or transportation, in connection with this Work, must be included in the amount bid by the Contractor and shall be paid to proper authorities before acceptance. The Contractor shall furnish all necessary permits and certificates and comply with all laws and ordinances applicable to the locality of the Work. The cost of all inspection fees levied by any governmental entity whatsoever shall be paid for by the Contractor.
- 13.13 In accordance with St. Tammany Police Jury Resolution 86-2672, as amended, the Contractor must provide in a form suitable to the Owner an affidavit stating that all applicable sales taxes for materials used on this project have been paid.
- 13.14 During the period that this Contract is in force, neither party to the Contract shall solicit for employment or employ an employee of the other.
- 13.15 All materials or equipment shown on the Drawings or included in these specifications shall be furnished unless written approval of a substitute is obtained from the Designer, or Owner if no separate designer.
- 13.16 If a potential supplier wishes to submit for prior approval a particular product other than a product specified in the contract documents, he shall do so no later than seven working days prior to the opening of bids. Within three days, exclusive of holidays and weekends, after such submission, the prime design professional shall furnish to both the public entity and the potential supplier written approval or denial of the product submitted. The burden of proof of the equality of the proposed substitute is upon the proposer and only that information formally submitted shall be used by the Designer in making its decision.

13.17 The decision of the Designer/Owner shall be given in good faith and shall be final.

14.00 QUANTITIES OF ESTIMATE, CHANGES IN QUANTITIES, EXTRA WORK

14.01 Whenever the estimated quantities of Work to be done and materials to be furnished under this Contract are shown in any of the documents, including the Proposal, such are given for use in comparing Bids and the right is especially reserved, except as herein otherwise specifically limited, to increase or diminish same not to exceed twenty-five percent (25%) by the Owner to complete the Work contemplated by this Contract. Such increase or diminution shall in no way vitiate this Contract, nor shall such increase or diminution give cause for claims or liability for damages.

14.02 The Owner shall have the right to make alterations in the line, grade, plans, form or dimensions of the Work herein contemplated, provided such alterations do not change the total cost of the Project, based on the originally estimated quantities, and the unit prices bid by more than twenty-five percent (25%) and provided further that such alterations do not change the total cost of any major item, based on the originally estimated quantities and the unit price bid by more than twenty-five (25%). (A major item shall be construed to be any item, the total cost of which is equal to or greater than ten percent (10%) of the total Contract Price, computed on the basis of the Proposal quantity and the Contract unit price). Should it become necessary, for the best interest of the Owner, to make changes in excess of that herein specified, the same shall be covered by supplemental agreement either before or after the commencement of the Work and without notice to the sureties. If such alterations diminish the quantity of Work to be done, such shall not constitute a claim for damages for anticipated profits for the Work dispensed with, but when the reduction in amount is a material part of the Work contemplated, the Contractor shall be entitled to only reasonable compensation as determined by the Owner for overhead and equipment charges which it may have incurred in expectation of the quantity of Work originally estimated, unless specifically otherwise provided herein; if the alterations increase the amount of Work, the increase shall be paid according to the quantity of Work actually done and at the price established for such Work under this Contract except where, in the opinion of the Owner, the Contractor is clearly entitled to extra compensation.

14.03 Without invalidating the Contract, the Owner may order Extra Work or make changes by altering, adding to, or deducting from the Work, the Contract sum being adjusted accordingly. The consent of the surety must first be obtained when necessary or desirable, all at the exclusive discretion of the Owner. All the Work of the kind bid upon shall be paid for at the price stipulated in the Proposal, and no claims for any Extra Work or material shall be allowed unless the Work is ordered in writing by the Owner.

14.04 Extra Work for which there is no price or quantity included in the Contract shall be paid for at a unit price or lump sum to be agreed upon in advance in writing by the Owner and Contractor. Where such price and sum cannot be agreed upon by both parties, or where this method of payment is impracticable, the Owner may, at its exclusive and unilateral discretion, order the Contractor to do such Work on a Force Account Basis.

14.05 In computing the price of Extra Work on a Force Account Basis, the Contractor shall be paid for all foremen and labor actually engaged on the specific Work at the current local rate of wage for each and every hour that said foremen and labor are engaged in such Work, plus ten percent (10%) of the total for superintendence, use of tools, overhead, direct & indirect costs/expenses, pro-rata applicable payroll taxes, pro-rata applicable workman compensation benefits, pro-rata insurance premiums and pro-rata reasonable profit. The Contractor shall furnish satisfactory evidence of the rate or rates of such insurance and tax. The Contractor will not be able to collect any contribution to any retirement plans or programs.

14.06 For all material used, the Contractor shall receive the actual cost of such material delivered at the site of the Work, as shown by original receipted bill, to which shall be added five percent (5%). There will be absolutely no additional surcharges or additional fees attached hereto with respect to this subsection.

14.07 For any equipment used that is owned by the Contractor, the Contractor shall be allowed a rental based upon the latest prevailing rental price, but not to exceed a rental price as determined by the Associated Equipment Distributors (A.E.D. Green Book).

- 14.08 The Contractor shall also be paid the actual costs of transportation for any equipment which it owns and which it has to transport to the Project for the Extra Work. There will be absolutely no additional surcharges or additional fees attached hereto with respect to this subsection.
- 14.09 If the Contractor is required to rent equipment for Extra Work, but not required for Contract items, it will be paid the actual cost of rental and transportation of such equipment to which no percent shall be added. The basis upon which rental cost are to be charged shall be agreed upon in writing before the Work is started. Actual rental and transportation costs shall be obtained from receipted invoices and freight bills.
- 14.10 No compensation for expenses, fees or costs incurred in executing Extra Work, other than herein specifically mentioned herein above, will be allowed.
- 14.11 A record of Extra Work on Force Account basis shall be submitted to the Owner on the day following the execution of the Work, and no less than three copies of such record shall be made on suitable forms and signed by both the Owner or his representative on the Project and the Contractor. All bids for materials used on extra Work shall be submitted to the Owner by the Contractor upon certified statements to which will be attached original bills covering the costs of such materials.
- 14.12 Payment for Extra Work of any kind will not be allowed unless the same has been ordered in writing by the Owner.

15.00 STATUS OF THE ENGINEER (NOT APPLICABLE)

16.00 INJURIES TO PERSONS AND PROPERTY

- 16.01 The Contractor shall be held solely and exclusively responsible for all injuries to persons and for all damages to the property of the Owner or others caused by or resulting from the negligence of itself, its employees or its agents, during the progress of or in connection with the Work, whether within the limits of the Work or elsewhere under the Contract proper or as Extra Work. This requirement will apply continuously and not be limited to normal working hours or days. The Owner's construction review is for the purpose of checking the Work product produced and does not include review of the methods employed by the Contractor or to the Contractor's compliance with safety measures of any nature whatsoever. The Contractor agrees to pay a reasonable attorney fee and other reasonable attendant costs of the Owner in the event it becomes necessary for the Owner to employ an attorney to enforce this section or to protect itself against suit over the Contractor's responsibilities. Attorney fees shall be at the prevailing hourly rate of the private sector. The attorney fee hourly rate shall not be less than \$175.00 per hour. All attorney fees collected shall be paid to the operating budget of the Office of the Parish President.
- 16.02 The Contractor must protect and support all utility infrastructures or other properties which are liable to be damaged during the execution of its Work. It shall take all reasonable and proper precautions to protect persons, animals and vehicles or the public from the injury, and wherever necessary, shall erect and maintain a fence or railing around any excavation, and place a sufficient number of lights about the Work and keep same burning from twilight until sunrise, and shall employ one or more watchmen as an additional security whenever needed. The Contractor understands and agrees that the Owner may request that security be placed on the premises to ensure and secure same. The Owner shall have exclusive authority to request placement of such security. Contractor agrees to retain and place security as requested, all at the sole expense of Contractor. Additional security shall not be considered a change order or reason for additional payment by the Owner. The Contractor must, as far as practicable and consistent with good construction, permit access to private and public property and leave fire hydrants, catch basins, streets, etc., free from encumbrances. The Contractor must restore at its own expense all injured or damaged property caused by any negligent act of omission or commission on its part or on the part of its employees or subcontractors, including, but not limited to, sidewalks, curbing, sodding, pipes conduits, sewers, buildings, fences, bridges, retaining walls, tanks, power lines, levees or any other building or property whatsoever to a like condition as existed prior to such damage or injury.

- 16.03 In case of failure on the part of the Contractor to restore such property or make good such damage, the Owner may upon forty-eight (48) hours' notice proceed to repair or otherwise restore such property as may be deemed necessary, and the cost thereof will be deducted from any monies due or which may become due under its Contract.
- 16.04 Contractor agrees to protect, defend, indemnify, save, and hold harmless St. Tammany Parish Government, its elected and appointed officials, departments, agencies, boards and commissions, their officers, agents servants, employees, including volunteers, from and against any and all claims, demands, expense and liability arising out of injury or death to any person or the damage, loss or destruction of any property to the extent caused by any negligent act or omission or willful misconduct of Contractor, its agents, servants, employees, and subcontractors, or any and all costs, expense and/or attorney fees incurred by St. Tammany Parish Government as a result of any claim, demands, and/or causes of action that results from the negligent performance or non-performance by Contractor, its agents, servants, employees, and subcontractors of this contract. Contractor agrees to investigate, handle, respond to, provide defense for and defend any such claims, demand, or suit at its sole expense and agrees to bear all other costs and expenses related thereto caused by any negligent act or omission or willful misconduct of Contractor, its agents, servants, employees, and subcontractors.
- 16.05 As to any and all claims against Owner, its agents, assigns, representatives or employees by any employee of Contractor, any Subcontractor, anyone directly or indirectly employed by any of them or anyone for whose acts as may be liable, the indemnification obligation under Paragraph 16.04 shall not be limited in any way or by any limitation on the amount or type of damages, compensation or benefits payable by or for Contractor or any Subcontractor under workmen's compensation acts, disability benefit acts or other employee benefit acts.
- 16.06 No road shall be closed by the Contractor to the public except by written permission of the Owner. If so closed, the Contractor shall maintain traffic over, through and around the Work included in his Contract, with the maximum practical convenience, for the full twenty-four hours of each day of the Contract, whether or not Work has ceased temporarily. The Contractor shall notify the Owner at the earliest possible date after the Contract has been executed and, in any case, before commencement of any construction that might in any way inconvenience or endanger traffic, in order that necessary and suitable arrangements may be determined. Any and all security, maintenance, labor or costs associated with traffic control herein shall be at the sole expense of Contractor. This expense shall be paid directly by the Contractor. This expense shall not be considered as a change order nor shall it allow the Contractor any additional cost reimbursement whatsoever. All traffic deviations herein shall be coordinated with the appropriate law enforcement officials of this Parish.
- 16.07 The convenience of the general public and residents along the Works shall be provided for in a reasonable, adequate and satisfactory manner. Where existing roads are not available as detours, and unless otherwise provided, all traffic shall be permitted to pass through the Work. In all such cases, the public shall have precedence over Contractor's vehicles insofar as the traveling public's vehicles shall not be unduly delayed for the convenience of the Contractor. In order that all unnecessary delay to the traveling public may be avoided, the Contractor shall provide and station competent flagmen whose sole duties shall consist of directing and controlling the movement of public traffic either through or around the Work. Any and all security, maintenance, labor or costs associated with traffic control herein shall be at the sole expense of Contractor. This expense shall be paid directly by the Contractor. This expense shall not be considered as a change order nor shall it allow the Contractor any additional cost reimbursement whatsoever. All traffic deviations herein shall be coordinated with the appropriate law enforcement officials of this Parish.
- 16.08 The Contractor shall arrange its Work so that no undue or prolonged blocking of business establishments will occur.
- 16.09 Material and equipment stored on the right of way or work site shall be so placed and the Work at times shall be so conducted as to ensure minimum danger and obstruction to the traveling public.
- 16.10 During grading operations when traffic is being permitted to pass through construction, the Contractor shall provide a smooth, even surface that will provide a satisfactory passageway

for use of traffic. The road bed shall be sprinkled with water if necessary to prevent a dust nuisance, provided the dust nuisance is a result of the Work.

- 16.11 Fire hydrants shall be accessible at all times to the Fire Department. No material or other obstructions shall be placed closer to a fire hydrant than permitted by ordinances, rules or regulations or within fifteen (15) feet of a fire hydrant, in the absence of such ordinance, rules or regulations.
- 16.12 The Contractor shall not, without the written permission of the Owner, do Work for a resident or property owner abutting the Work at the time that this Work is in progress.
- 16.13 No Work of any character shall be commenced on railroad right-of-way until the Railroad Company has issued a permit to the Owner and has been duly notified by the Contractor in writing (with a copy forwarded to the Owner) of the date it proposes to begin Work, and until an authorized representative of the Railroad Company is present, unless the Railroad Company waives such requirements. All Work performed by the Contractor within the right-of-way limits of the railroad shall be subject to the inspection and approval of the chief engineer of the Railroad Company or its authorized representative. Any precautions considered necessary by said chief engineer to safeguard the property, equipment, employees and passengers of the Railroad Company shall be taken by the Contractor without extra compensation. The Contractor shall, without extra compensation, take such precautions and erect and maintain such tell-tale or warning devices as the Railroad Company considers necessary to safeguard the operation of its trains. The temporary vertical and horizontal clearance specified by the chief engineer of the Railroad Company in approving these shall be maintained at all times. No steel, brick, pipe or any loose material shall be left on the ground in the immediate vicinity of the railway track. Before any Work is done within Railroad right of way, the Contractor shall provide and pay all costs of any special insurance requirements of the Railroad.
- 16.14 The Contractor, shall, without extra compensation, provide, erect, paint and maintain all necessary barricades. Also, without extra compensation, the Contractor shall provide suitable and sufficient lights, torches, reflectors or other warning or danger signals and signs, provide a sufficient number of watchmen and flagmen and take all the necessary precautions for the protection of the Work and safety of the Public.
- 16.15 The Contractor shall erect warning signs beyond the limits of the Project, in advance of any place on the Project where operations interfere with the use of the road by traffic, including all intermediate points where the new Work crosses or coincides with the existing road. All barricades and obstructions shall be kept well painted and suitable warning signs shall be placed thereon. All barricades and obstructions shall be illuminated at night and all lights or devices for this purpose shall be kept burning from sunset to sunrise.
- 16.16 Whenever traffic is maintained through or over any part of the Project, the Contractor shall clearly mark all traffic hazards. No direct payment will be made for barricades, signs and illumination therefore or for watchmen or flagmen.
- 16.17 The Contractor will be solely and completely responsible for conditions on the job site, including safety of all persons and property during performance of the Work. This requirement will apply continuously and not be limited to normal working hours. The duty of the Owner to conduct construction review of the Contractor's performance is not intended to include review of the adequacy of the Contractor's safety measures, in, or near the construction site.

17.00 SANITARY PROVISIONS

- 17.01 The Contractor shall provide and maintain in a neat, sanitary condition such accommodations for the use of its employees as may be necessary to comply with the rules and regulations of the State Health Agency or of the other authorities having jurisdiction and shall permit no public nuisance.

18.00 RIGHTS OF WAY

18.01 The Owner will furnish the Contractor with all necessary rights-of-way for the prosecution of the Work. The rights of way herein referred to shall be taken to mean only permission to use or pass through the locations or space in any street, highway, public or private property in which the Contractor is to prosecute the Work.

18.02 It is possible that all lands and rights of way may not be obtained as herein contemplated before construction begins, in which event the Contractor shall begin its Work upon such land and rights of way as the Owner may have previously acquired. Any delay in furnishing these lands by the Owner can be deemed proper cause for adjustment in the Contract amount and/or in the time of completion.

19.00 PROTECTION AND RESTORATION OF PROPERTY AND LANDSCAPE

19.01 The Contractor shall not enter upon private property for any purpose without first obtaining permission from the Owner, as well as the private property owner and/or and private property Lessees. The Contractor shall use every precaution necessary for the preservation of all public and private property, monuments, highway signs, telephone lines, other utilities, etc., along and adjacent to the Work; the Contractor shall use every precaution necessary to prevent damage to pipes, conduits, and other underground structures; and shall protect carefully from disturbance or damage all land monuments and property marks until an authorized agent has witnessed or otherwise referenced their location and shall not remove them until directed. The street and highway signs and markers that are to be affected by the Work shall be carefully removed when the Work begins and stored in a manner to keep them clean and dry. The Contractor must obtain all necessary information in regard to existing utilities and shall give notice in writing to the owners or the proper authorities in charge of streets, gas, water, pipes, electric, sewers and other underground structures, including conduits, railways, poles and pole lines, manholes, catch basins, fixtures, appurtenances, and all other property that may be affected by the Contractor's operations, at least forty-eight (48) hours before its operations will affect such property. The Contractor shall not hinder or interfere with any person in the protection of such Work or with the operation of utilities at any time. When property, the operation of railways, or other public utilities are endangered, the Contractor shall at its own expense, maintain flagmen or watchmen and any other necessary precautions to avoid interruption of service or damage to life or property, and it shall promptly repair, restore, or make good any injury or damage caused by its negligent operations in an acceptable manner. The Contractor must also obtain all necessary information in regard to the installation of new cables, conduits, and transformers, and make proper provisions and give proper notifications, in order that same can be installed at the proper time without delay to the Contractor or unnecessary inconvenience to the Owner.

19.02 The Contractor shall not remove, cut or destroy trees, shrubs, plants, or grass that are to remain in the streets or those which are privately owned, without the proper authority. Unless otherwise provided in the Special Provisions or the Proposal, the Contractor shall replace and replant all plants, shrubs, grass and restore the grounds back to its original good condition to the satisfaction of the Owner and/or the property owner. The Contractor shall assume the responsibility of replanting and guarantees that plants, shrubs, grass will be watered, fertilized and cultivated until they are in a growing condition. No direct payment will be made for removing and replanting of trees, shrubs, plants or grass unless such items are set forth in the Proposal.

19.03 When or where direct damage or injury is done to public or private property by or on account of any negligent act, omission, neglect or otherwise of the Contractor, it shall make good such damage or injury in an acceptable manner.

20.00 CONTRACTORS RESPONSIBILITY FOR WORK

20.01 Until final acceptance of the Work by the Owner as evidence by approval of the final estimate, the Work shall be in the custody and under the charge and care of the Contractor and it shall take every necessary precaution against injury or damage to any part thereof by the action of the elements or from the non-execution of the Work; unless otherwise provided for elsewhere in the Specifications or Contract. The Contractor shall rebuild, repair, restore and make good, without extra compensation, all injuries or damages to any portion of the Work occasioned by any of the above causes before its completion and

acceptance, and shall bear the expenses thereof. In case of suspension of the Work from any cause whatever, the Contractor shall be responsible for all materials and shall properly and securely store same, and if necessary, shall provide suitable shelter from damage and shall erect temporary structures where necessary. If in the exclusive discretion of the Owner, any Work or materials shall have been damaged or injured by reason of failure on the part of the Contractor or any of its Subcontractors to so protect the Work, such materials shall be removed and replaced at the sole expense of the Contractor. Such amount shall be deducted from any sum due or to be due Contractor.

20.02 The Contractor shall give all notice and comply with all Federal, State, and local laws, ordinances, and regulations in any manner affecting the conduct of the Work, and all such orders and decrees as exist, or may be enacted by bodies or tribunals having any jurisdiction or authority over the Work, and shall indemnify and hold harmless the Owner against any claim or liability arising from, or based on, the violation of any such law, ordinance, regulation, order or decree, whether by itself, its employees or Subcontractors.

21.00 TESTS AND INSPECTIONS CORRECTION & REMOVAL OF DEFECTIVE WORK

21.01 Contractor warrants and guarantees to Owner that all materials and equipment will be new unless otherwise specified and that all Work will be of good quality and free from faults or defects and in accordance with the requirements of the Contract Documents. All unsatisfactory Work, all faulty or Defective Work and all Work not conforming to the requirements of the Contract Documents at the time of acceptance shall be considered Defective. Prompt and reasonable notice of all defects shall be given to the Contractor.

21.02 If the Contract Documents, laws, ordinances, rules, regulations or orders of any public authority having jurisdiction require any Work to specifically be inspected, tested or approved by some public body, Contractor shall assume full responsibility therefor, pay all costs in connection therewith and furnish Owner the required certificates of inspection, testing or approval. All other inspections, tests and approval required by the Contract Documents shall be performed by organizations acceptable to Owner and Contractor and the costs thereof shall be borne by the Contractor unless otherwise specified.

21.03 Contractor shall give Owner timely notice of readiness of the Work for all inspections, tests or approvals. If any such Work required to be inspected, tested or approved is covered without written approval of Owner, it must, if requested by Owner, be uncovered for observation, and such uncovering shall be at Contractor's expense unless Contractor has given Owner timely notice of its intention to cover such Work and Owner has not acted with reasonable promptness in response to such notice.

21.04 Neither observations by Owner nor inspections, tests or approvals shall relieve Contractor from its obligations to perform the Work in accordance with the requirements of the Contract Document.

21.05 Owner and its representatives will at reasonable times have access to the Work. Contractor shall provide proper and safe facilities for such access and observation of the Work and also for any inspection or testing thereof by others.

21.06 If any Work is covered contrary to the written request of Owner, it must, be uncovered for Owner's observation and replaced at Contractor's expense. If any Work has been covered which Owner has not specifically requested to observe prior to its being covered, or if Owner considers it necessary or advisable that covered Work be inspected or tested by others, the Contractor, at Owner's request, shall uncover, expose or otherwise make available for observations, inspections or testing as Owner may require, that portion of the Work in question, furnishing all necessary labor, material and equipment. If it is found that such Work is Defective, Contractor shall bear all the expenses of such uncovering, exposure, observation, inspection and testing and of satisfactory reconstruction, including compensation for additional professional services, and an appropriate deductive Change Order shall be issued. If, however, such Work is not found to be Defective, Contractor shall be allowed an increase in the Contract Price or an extension of the Contract Time, or both, directly attributable to such uncovering, exposure, observation, inspection, testing and reconstruction.

- 21.07 If the Work is Defective, or Contractor fails to supply sufficient skilled workmen or suitable materials or equipment, or if the Contractor fails to make prompt payments to Subcontractors or for labor, materials or equipment, Owner may order Contractor to stop the Work, or any portion thereof, until the cause of such order has been eliminated; however, this right of Owner to stop the Work shall not give rise to any duty on the part of Owner to exercise this right for the benefit of Contractor or any other party.
- 21.08 Prior to approval of final payment, Contractor shall promptly, without cost to Owner and as specified by Owner, either correct any Defective Work, whether or not fabricated, installed or completed, or if the Work has been rejected by Owner, remove it from the site and replace it with non-defective Work. If Contractor does not correct such Defective Work or remove and replace such rejected Work within a reasonable time, all as specified in a written notice from Owner, Owner may have the deficiency corrected or the rejected Work removed and replaced. All direct or indirect costs of such correction or removal and replacement including compensation for additional professional services shall be paid by Contractor, and an appropriate deductive Change Order shall be issued. Contractor shall also bear the expense of making good all Work of others destroyed or damaged by its correction, removal or replacement of its Defective Work.
- 21.09 If, after the approval of final payment and prior to the expiration of one year after the date of Substantial Completion or such longer period of time as may be prescribed by law or by the terms of any applicable special guarantee required by the Contract Documents, any Work is found to be Defective, Contractor shall promptly, without cost to Owner and in accordance with Owner's written instructions, either correct such Defective Work or if it has been rejected by Owner, remove it from the site and replace it with non-defective Work. If Contractor does not promptly comply with the terms of such instructions, Owner may have the Defective Work corrected or the rejected Work removed and replaced, and all direct and indirect costs of such removal and replacement, including compensation for additional professional services, shall be paid by Contractor. The Contractor agrees to pay a reasonable attorney fee and other reasonable attendant costs of the Owner in the event it becomes necessary for the Owner to employ an attorney to enforce this section or to protect itself against suit over the Contractor's responsibilities. Attorney fees shall be at the prevailing hourly rate of the private sector. The attorney fee hourly rate shall not be less than \$175.00 per hour. All attorney fees collected shall be paid to the operating budget of the Office of the Parish President.
- 21.10 If, instead of requiring correction or removal and replacement of Defective Work, Owner (and prior to approval of final payment) prefers to accept it, the Owner may do so. In such case, if acceptance occurs prior to approval of final payment, a Change Order shall be issued incorporating the necessary revisions in the Contract Documents, including appropriate reduction in the Contract Price, or, if the acceptance occurs after approval of final payment, an appropriate amount shall be paid by Contractor to Owner.
- 21.11 If Contractor should fail to progress the Work in accordance with the Contract Documents, including any requirements of the Progress Schedule, Owner, after seven (7) days written Notice to Contractor, may, without prejudice to any other remedy Owner may have, make good such deficiencies and the cost thereof including compensation for additional professional services shall be charged against Contractor. In such cases, a Change Order shall be issued incorporating the necessary revisions in the Contract Documents including an appropriate reduction in the Contract Price. If the payments then or thereafter due Contractor are not sufficient to cover such amount, Contractor shall pay the difference to Owner.
- 21.12 The Owner may appoint representatives to make periodic visits to the site and observe the progress and quality of the executed Work. These representatives shall be governed by the same restrictions placed on the Owner by these Specifications. The governing body of the Federal, State or local government exercising authority in the area of the Work may appoint representatives to observe the progress and quality of the Work. Contractor shall cooperate with and assist these representatives in the performance of their duties.
- 21.13 The Contractor shall be responsible for the faithful execution of its Contract and the presence or absence of the Owner's or Government's Representative is in no way or manner to be presumed or assumed to relieve in any degree the responsibility or obligation of the Contractor.

- 21.14 The Contractor shall notify the Owner and the Governmental Agency having jurisdiction as to the exact time at which it is proposed to begin Work so the Owner may provide for inspection of all materials, foundations, excavations, equipment, etc., and all or any part of the Work and to the preparation or manufacture of materials to be used whether within the limits of the Work or at any other place.
- 21.15 The Owner or its representatives shall have free access to all parts of the Work and to all places where any part of the materials to be used are procured, manufactured or prepared. The Contractor shall furnish the Owner all information relating to the Work and the material therefor, which may be deemed necessary or pertinent, and with such samples of materials as may be required. The Contractor, at its own expense, shall supply such labor and assistance as may be necessary in the handling of materials for proper inspection or for inspection of any Work done by it.
- 21.16 No verbal instructions given to the Contractor by the Owner, Project Representative or any of their agents shall change or modify the written Contract. Contractors shall make no claims for additional payments or time based upon verbal instructions.

22.00 SUBSURFACE CONDITIONS

- 22.01 It is understood and agreed that the Contractor is familiar with the subsurface conditions that will be encountered and its price bid for the Work includes all of the costs involved for Work in these conditions and it is furthermore agreed that it has taken into consideration, prior to its Bid and acceptance by Owner, all of the subsurface conditions normal or unusual that might be encountered in the location of the Work.
- 22.02 Should the Contractor encounter during the progress of the Work subsurface conditions at the site materially differing from those shown on the Drawings or indicated in the Specifications, the attention of the Owner shall be directed to such conditions before the conditions are disturbed. If the Owner finds that the conditions materially differ from those shown on the Drawings or indicated in the Specifications, it shall at once make such changes in the Drawings or Specifications as it may find necessary, and any increase or decrease in cost or extension of time resulting from such changes shall be adjusted in the same manner as provided for changes for Extra Work. The Contractor shall submit breakdowns of all costs in a manner as instructed and approved by the Owner.

23.00 REMOVAL AND DISPOSAL OF STRUCTURES AND OBSTRUCTIONS

- 23.01 Bidder shall thoroughly examine the site of the Work and shall include in its Bid the cost of removing all structures and obstructions in the way of the Work.
- 23.02 The Contractor shall remove any existing structures or part of structures, fence, building or other encumbrances or obstructions that interfere in any way with the Work. Compensations for the removal of any structure shall be made only if the item(s) to be removed was/were listed as pay item(s) on the Proposal.
- 23.03 If called for in the Special Conditions, all privately and publicly owned materials and structures removed shall be salvaged without damage and shall be piled neatly and in an acceptable manner upon the premises if it belongs to an abutting property owner, otherwise at accessible points along the improvements. Materials in structures which is the property of the Owner or property of any public body, private body or individual which is fit for use elsewhere, shall remain property of the original Owner. It shall be carefully removed without damage, in sections which may be readily transported; same shall be stored on or beyond the right of way. The Contractor will be held responsible for the care and preservation for a period of ten (10) days following the day the last or final portion of the materials stored at a particular location are placed thereon. When privately owned materials are stored beyond the right of way, the Contractor will be held responsible for such care and preservation for a period of ten (10) days responsibility period for care and preservation of the materials begins. The Contractor must furnish the Owner with evidence satisfactory that the proper owner of the materials has been duly notified by the Contractor that the said owner must assume responsibility for its materials on the date following the Contractor's ten (10) day responsibility.

24.00 INSURANCE

- 24.01 Contractor shall secure and maintain at its expense such insurance that will protect it and the Parish from claims for injuries to persons or damages to property which may arise from or in connection with the performance of Services or Work hereunder by the Contractor, his agents, representatives, employees, and/or subcontractors. The cost of such insurance shall be included in Contractor's bid.
- 24.02 The Contractor shall not commence work until it has obtained all insurance as required for the Parish Project. If the Contractor fails to furnish the Parish with the insurance protection required and begins work without first furnishing Parish with a currently dated certificate of insurance, the Parish has the right to obtain the insurance protection required and deduct the cost of insurance from the first payment due the Contractor. Further deductions are permitted from future payments as are needed to protect the interests of the Parish including, but not limited to, renewals of all policies.
- 24.03 Payment of Premiums: The insurance companies issuing the policy or policies shall have no recourse against the Parish of St. Tammany for payment of any premiums or for assessments under any form of policy.
- 24.04 Deductibles: Any and all deductibles in the described insurance policies shall be assumed by and be at the sole risk of the Contractor.
- 24.05 Authorization of Insurance Company(ies) and Rating: All insurance companies must be authorized to do business in the State of Louisiana and shall have an A.M. Best rating of no less than A-, Category VII.
- 24.06 Policy coverages and limits must be evidenced by Certificates of Insurance issued by Contractor's carrier to the Parish and shall reflect:

Date of Issue: Certificate must have current date.

Named Insured: The legal name of Contractor under contract with the Parish and its principal place of business shall be shown as the named insured on all Certificates of Liability Insurance.

Name of Certificate Holder: St. Tammany Parish Government, Office of Risk Management, P. O. Box 628, Covington, LA 70434

Project Description: A brief project description, including Project Name, Project Number and/or Contract Number, and Location.

Endorsements and Certificate Reference: All policies must be endorsed to provide, and certificates of insurance must evidence the following:

Waiver of Subrogation: The Contractor's insurers will have no right of recovery or subrogation against the Parish of St. Tammany, it being the intention of the parties that all insurance policy(ies) so affected shall protect both parties and be the primary coverage for any and all losses covered by the below described insurance. *Policy endorsements required for all coverages.*

Additional Insured: The Parish of St. Tammany shall be named as additional named insured with respect to general liability, marine liability, pollution/environmental liability, automobile liability and excess liability coverages. *Policy endorsements required.*

Hold Harmless: Contractor's liability insurers shall evidence their cognizance of the Hold Harmless and Indemnification in favor of St. Tammany Parish Government by referencing same on the face of the Certificate(s) of Insurance.

Cancellation Notice: Producer shall provide thirty (30) days prior written notice to the Parish of policy cancellation or substantive policy change.

24.07 The types of insurance coverage the Contractor is required to obtain and maintain throughout the duration of the Contract, include, but is not limited to:

1. Commercial General Liability insurance with a Combined Single Limit for bodily injury and property damage of at least \$1,000,000 per Occurrence/\$3,000,000 General Aggregate/Products-Completed Operations Per Project. The insurance shall provide for and the certificate(s) of insurance shall indicate the following coverages:
 - a) Premises - operations;
 - b) Broad form contractual liability;
 - c) Products and completed operations;
 - d) Personal Injury;
 - e) Broad form property damage;
 - f) Explosion and collapse.
2. Marine Liability/Protection and Indemnity insurance is required for any and all vessel and/or marine operations in the minimum limits of \$1,000,000 per occurrence/\$2,000,000 per project general aggregate. The coverage shall include, but is not limited to, the basic coverages found in the Commercial General Liability insurance and coverage for third party liability.
3. Contractors' Pollution Liability and Environmental Liability insurance in the minimum amount of \$1,000,000 per occurrence, \$2,000,000 general aggregate and include coverage for full contractual liability and for all such environmental and/or hazardous waste exposures affected by this project.
4. Business Automobile Liability insurance with a Combined Single Limit of \$1,000,000 per Occurrence for bodily injury and property damage, and shall include coverage for the following:
 - a) Any automobiles;
 - b) Owned automobiles;
 - c) Hired automobiles;
 - d) Non-owned automobiles;
 - e) Uninsured motorist.
5. Workers' Compensation/Employers Liability insurance: worker's compensation insurance coverage and limits as statutorily required; Employers' Liability Coverage shall be not less than \$1,000,000 each accident, \$1,000,000 each disease, \$1,000,000 disease policy aggregate, except when projects include exposures covered under the United States Longshoremen and Harbor Workers Act, Maritime and/or Jones Act and/or Maritime Employers Liability (MEL) limits shall be not less than \$1,000,000/\$1,000,000/\$1,000,000. *Coverage for owners, officers and/or partners shall be included in the policy and a statement of such shall be made by the insuring producer on the face of the certificate.*
6. Owners Protective Liability (OPL) (formerly Owners and Contractors Protective Liability (OCP) Insurance) shall be furnished by the Contractor naming St. Tammany Parish Government as the Named Insured and shall provide coverage in the minimum amount of \$1,000,000 combined single limit (CSL) each occurrence, \$2,000,000 aggregate. Any project valued in excess of \$3,000,000 shall be set by the Office of Risk Management. The policy and all endorsements shall be addressed to St. Tammany Parish Government, Office of Risk Management, P. O. Box 628, Covington, LA 70434.
7. Builder's Risk Insurance shall be required on buildings, sewage treatment plants and drainage pumping stations, and shall be written on an "all-risk" or equivalent policy form in the amount of the full value of the initial Contract sum, plus value of subsequent Contract modifications and cost of materials supplied or installed by others, comprising 100% total value for the entire project including foundations. Deductibles should not exceed \$5,000 and Contractor shall be responsible for any and all policy deductibles. This insurance shall cover portions of the work stored off the site, and also portions of the work in transit. In addition, Installation Floater

Insurance, on an “all-risk” form, will be carried on all pumps, motors, machinery and equipment on the site or installed. Both the Builder’s Risk Insurance and the Installation Floater Insurance shall include the interests of the Owner, Contractor, Subcontractors, and Sub-subcontractors and shall terminate only when the Project has been accepted. St. Tammany Parish Government, P. O. Box 628, Covington, LA 70434 shall be the first named insured on the Builder’s Risk and Installation Floater Insurance.

8. Professional Liability (errors and omissions) insurance in the sum of at least One Million Dollars (\$1,000,000) per claim with Two Million Dollars (\$2,000,000) annual aggregate.
 9. An umbrella policy or excess policy may be required and/or allowed to meet minimum coverage limits, subject to the review and approval by St. Tammany Parish Government, Office of Risk Management.
- 24.08 All policies of insurance shall meet the requirements of the Parish of St. Tammany prior to the commencing of any work. The Parish of St. Tammany has the right, but not the duty, to approve all insurance policies prior to commencing of any work. If at any time, it becomes known that any of the said policies shall be or becomes unsatisfactory to the Parish of St. Tammany as to form or substance; or if a company issuing any such policy shall be or become unsatisfactory to the Parish of St. Tammany, the Contractor shall promptly obtain a new policy, timely submit same to the Parish of St. Tammany for approval and submit a certificate thereof as provided above. The Parish agrees to not unreasonably withhold approval of any insurance carrier selected by Contractor. In the event that Parish cannot agree or otherwise authorize said carrier, Contractor shall have the option of selecting and submitting new insurance carrier within 30 days of said notice by the Parish. In the event that the second submission is insufficient or is not approved, then the Parish shall have the unilateral opportunity to thereafter select a responsive and responsible insurance carrier all at the cost of Contractor and thereafter deduct from Contractor's fee the cost of such insurance.
- 24.09 Upon failure of Contractor to furnish, deliver and/or maintain such insurance as above provided, the contract, at the election of the Parish of St. Tammany, may be forthwith declared suspended, discontinued or terminated. Failure of the Contractor to maintain insurance shall not relieve the Contractor from any liability under the contract, nor shall the insurance requirements be construed to conflict with the obligation of the Contractor concerning indemnification.
- 24.10 Contractor shall maintain a current copy of all annual insurance policies and provide same to the Parish of St. Tammany as may be reasonably requested.
- 24.11 It shall be the responsibility of Contractor to require that these insurance requirements are met by all contractors and sub-contractors performing work for and on behalf of Contractor. Contractor shall further ensure the Parish is named as additional insured on all insurance policies provided by said contractor and/or sub-contractor throughout the duration of the project, and that renewal certificates for any policies expiring prior to the Parish’s final acceptance of the project shall be furnished to St. Tammany Parish Government, Department of Legal, Office of Risk Management, without prompting.

NOTICE:

These are only an indication of the coverages that are generally required. Additional coverages and/or limits may be required for projects identified as having additional risks or exposures. Please note that some requirements listed may not necessarily apply to your specific services. St. Tammany Parish Government reserves the right to remove, replace, make additions to and/or modify any and all of the insurance requirement language upon review of the final scope of services presented to Office of Risk Management prior to execution of a contract for services.

For inquiries regarding insurance requirements, please contact:

**St. Tammany Parish Government
Office of Risk Management
P. O. Box 628
Covington, LA 70434
Telephone: 985-898-5226
Email: riskman@stpgov.org**

24.12 Nothing contained in these insurance requirements is to be construed as limiting the extent of the Contractor's Responsibility for payment of damages resulting from its operations under this Contract.

25.00 OWNER'S RIGHT TO OCCUPANCY

25.01 The Owner shall have the right to use, at any time, any and all portions of the Work that have reached such a stage of completion as to permit such occupancy, provided such occupancy does not hamper the Contractor or prevent its efficient completion of the Contract or be construed as constituting an acceptance of any part of the Work.

25.02 The Owner shall have the right to start the construction of houses, structures or any other building concurrent with the Contractor's Work.

26.00 SURVEY HORIZONTAL AND VERTICAL CONTROL

26.01 The Owner shall provide surveys for construction to establish reference points which in its judgment are necessary to enable Contractor to layout and proceed with its Work. Contractor shall be responsible for surveying and laying out the Work and shall protect and preserve the established reference points and shall make no changes or relocations without the prior written approval of the Owner. Contractor shall report to Owner whenever any reference point is lost or destroyed and the Owner shall decide if the reference point shall be replaced by its or the Contractor's forces.

26.02 The Contractor shall establish lines and grades with its own forces in sufficient number and location for the proper execution of the Work.

26.03 If the Contractor, during the construction, damages the established property corners and/or other markers and thereafter requests the Owner to re-stake same in order to complete the project, this expense will be borne solely by the Contractor.

27.00 TERMINATION OF THE CONTRACT, OWNER'S AND CONTRACTORS RIGHT TO STOP WORK.

27.01 If the Contractor should be adjudged bankrupt (voluntarily or involuntarily) or if it should make a general assignment for the benefit of its creditors, or if a receiver should be appointed on account of its insolvency, or if it should persistently or repeatedly refuse or should fail (except in cases for which extension of time is provided) to supply enough properly skilled workmen or proper materials, or if it should fail to make prompt payment to Subcontractors or for material or labor, or persistently disregard laws, ordinances or the instructions of the Owner, or otherwise be guilty of a substantial violation of any provision of the Contract, then the Owner, upon the certificate of the Owner that, in its unilateral discretion and judgment, believes sufficient cause exists to justify such action, may, without prejudice to any other right or remedy and after giving the Contractor ten (10) calendar days written notice, terminate the employment of the Contractor and take possession of the premises and of all materials, tools and appliances thereon and finish the Work by whatever method the Owner may deem expedient.

27.02 Failure of the Contractor to start the Work within the time limit specified herein or substantial evidence that the progress being made by the Contractor is sufficient to complete the Work within the specified time shall be grounds for termination of the Contract by the Owner.

- 27.03 Before the Contract is terminated, the Contractor and its surety will first be notified in writing by the Owner of the conditions which make termination of the Contract imminent. When after ten (10) calendar days' notice is given and if satisfactory effort has not been made by the Contractor or its surety to correct the conditions, the Owner may declare, in its exclusive discretion, that the Contract is terminated and so notify the Contractor and its surety accordingly.
- 27.04 Upon receipt of notice from the Owner that the Contract has been terminated, the Contractor shall immediately discontinue all operations. The Owner may then proceed with the Work in any lawful manner that it may elect until Work is finally completed.
- 27.05 The exclusive right is reserved to the Owner to take possession of any machinery, implements, tools or materials of any description that shall be found upon the Work, to account for said equipment and materials, and to use same to complete the Project. When the Work is finally completed, the total cost of same will be computed. If the total cost is less than the Contract Price, the difference will not be paid to the Contractor or its surety.
- 27.06 In case of termination, all expenses incident to ascertaining and collecting losses under the Bond, including legal services, shall be assessed against the Bond.
- 27.07 If the Work should be stopped under any order of any court or public authority for period of sixty (60) calendar days, through no act or fault of the Contractor or anyone employed by it, or if the Owner shall fail to pay the Contractor within a reasonable time any sum certified by the Owner, then the Contractor may, upon ten (10) calendar days written notice to the Owner, stop Work or terminate this Contract and recover from the Owner payment for all Work properly and professionally executed in a workmanlike manner. This loss specifically includes actual cost of materials and equipment, together with all wages inclusive of all federal, state, and local tax obligations. This loss specifically includes reimbursement of all insurances on a pro-rata basis from the date of termination to date of policy period. This loss excludes and specifically does not include recovery by the Contractor for lost profit, indirect & direct expenses, overhead, and the like.

28.00 PAYMENTS TO THE CONTRACTOR

- 28.01 Monthly certificates for partial payment, in a form approved by the Owner, shall be transmitted to the Owner upon receipt from the Contractor and acceptance by the Owner. In accordance with LSA-R.S. 38:2248(A), when the Contract Price is less than five hundred thousand dollars, these certificates shall be equal to ninety percent (90%) of both the Work performed and materials stored at the site; and when the Contract Price is five hundred thousand dollars or more, these certificates shall be equal to ninety-five percent (95%) of both the Work performed and materials stored at the site. Partial payment certificates shall include only Work, materials and equipment that are included in official Work Order and which meet the requirements of plans, Specifications and Contract Documents. These monthly estimates shall show the amount of the original estimate for each item, the amount due on each item, the gross total, the retained percentage, the amount previously paid and the net amount of payment due.
- 28.02 After final completion and acceptance by the Owner of the entire Work, and when the Contract Price is less than five hundred thousand dollars, the Owner shall issue to the Contractor Certificate of Payment in sum sufficient to increase total payments to ninety percent (90%) of the Contract Price. After final completion and acceptance by the Owner of the entire Work, and when the Contract Price is five hundred thousand dollars or more, the Owner shall issue to the Contractor Certificate of Payment in sum sufficient to increase total payments to ninety-five percent (95%) of the Contract Price.
- 28.03 When the Contract Price is less than five hundred thousand dollars, the final payment certificate of the remaining ten percent (10%) of the Contract Price, minus any deduction for deficient or Defective Work or other applicable deductions, will be issued by the Owner forty-five (45) days after filing acceptance in the Mortgage Office of the Parish and a Clear Liens and Privilege Certificate has been secured. When the Contract Price is five hundred thousand dollars or more, the final payment certificate of the remaining five percent (5%) of the Contract Price, minus any deduction for deficient or Defective Work or other applicable deductions, will be issued by the Owner forty-five (45) days after filing acceptance in the Mortgage Office of the Parish and a Clear Liens and Privilege Certificate

has been secured. Before issuance of the final payment certificate, the Contractor shall deposit with the Owner a certificate from the Clerk of Court and Ex-Officio Recorder of Mortgages from the Parish in which the Work is performed to the effect that no liens have been registered against Contract Work.

- 28.04 When, in the opinion of the Contractor, the Work provided for and contemplated by the Contract Documents has been substantially completed, the Contractor shall notify the Owner in writing that the Work is substantially complete and request a final inspection. The Owner shall proceed to perform such final inspection accompanied by the Contractor. Any and all Work found by this inspection to be Defective or otherwise not in accordance with the plans and Specifications shall be corrected to the entire satisfaction of the Owner and at the sole expense of the Contractor. If the Contract is found to be incomplete in any of its details, the Contractor shall at once remedy such defects, and payments shall be withheld and formal acceptance delayed until such Work has been satisfactorily completed.
- 28.05 If payment is requested on the basis of materials and equipment not incorporated in the Work, but delivered and suitably stored and protected from damage and theft at the site, the Request for Payment shall also be accompanied by such data, satisfactory to the Owner, as will establish Owner's title to the material and equipment and protect its interest therein, including applicable insurance.
- 28.06 Each subsequent Request for Payment shall include an affidavit of Contractor stating that all previous progress payments received on account of the Work have been applied to discharge in full all of Contractor's obligations reflected in prior Request for Payment.
- 28.07 Each subsequent request for payment shall include an affidavit by Contractor that Contractor, all subcontractors, agents, material suppliers and all other persons supplying material to the project upon which State of Louisiana and/or St. Tammany sales taxes are lawfully due have paid these taxes and that all supplies and materials purchased for this project and for which Contractor has been paid have had all lawfully due State and/or St. Tammany sales taxes paid.
- 28.08 The Bid Proposal, unless otherwise modified in writing, and the Contract constitute the complete Project. The Contract Prices constitute the total compensation payable to Contractor and the cost of all of the Work and materials, taxes, permits and incidentals must be included into the Bid submitted by the Contractor and included into those items listed on the Proposal.
- 28.09 Any additional supporting data required by the Owner in order to substantiate Contractor's request for payment shall be furnished by Contractor at no cost to the Owner.
- 28.10 Owner may withhold from payment to Contractor as may be necessary to protect itself from loss on account of:
- (1) Defective and/or inferior work;
 - (2) Damage to the property of Owner or others caused by Contractor;
 - (3) Failure by Contractor to make payments properly to sub-contractors or to pay for labor, materials or equipment used on this project;
 - (4) Failure by Contractor to pay taxes due on materials used on this project;
 - (5) Damage by Contractor to another Contractor;
 - (6) Insolvency;
 - (7) Bankruptcy, voluntary or involuntary;
 - (8) Revocation of corporate status;
 - (9) Failure to follow corporate formalities;
 - (10) Unprofessional activities;
 - (11) Unworkmanlike performance;
 - (12) Fraud and/or misrepresentation of any kind.

29.00 ACCEPTANCE AND FINAL PAYMENT(S)

- 29.01 Upon receipt of written notice from Contractor that the work is substantially complete and usable by Owner or the Public in suitable manner, the Owner and the Contractor shall jointly inspect the work.
- 29.02 If the Owner by inspection determines that the work is not substantially complete in a

suitable manner for use by the Owner or the Public, then the Owner shall so notify the Contractor in writing stating such reason. All reasons need not be disclosed unless actually known. The Owner is afforded an opportunity to amend said notices as are reasonably possible.

- 29.03 If the Owner by its inspection determines that the work is substantially complete, it shall prepare a list of all items not satisfactorily completed and shall notify the Contractor and Owner in writing that the work is substantially complete and subject to satisfactory resolution of those items on the list (punch list). Punch lists may be amended from time to time by Owner in the event that additional deficiencies are discovered. In accordance with LSA-R.S. 38:2248(B), any punch list generated during a construction project shall include the cost estimates for the particular items of work the design professional has developed based on the mobilization, labor, material, and equipment costs of correcting each punch list item. The design professional shall retain his working papers used to determine the punch list items cost estimates should the matter be disputed later. The contract agency shall not withhold from payment more than the value of the punch list. Punch list items completed shall be paid upon the expiration of the forty-five (45) day lien period. The provisions of this Section shall not be subject to waiver.
- 29.04 Upon determination of substantial completeness with the punch list, the Contract Time is interrupted and the Contractor is given a reasonable time not to exceed thirty (30) consecutive calendar days to effect final completion by correcting or completing all of those items listed on the punch list. If the items on the punch list are not completed in a satisfactory manner within the thirty day period, then the Contract Time will begin to run again and will include for purposes of determining liquidated damages the thirty day period the grace period being withdrawn.
- 29.05 Upon receipt by Owner of written determination that all work embraced by the contract has been completed in a satisfactory manner, the Owner shall provide a written acceptance to Contractor who shall record Owner's written acceptance with the recorder of Mortgages, St. Tammany Parish. The Contractor shall properly prepare, submit and pay for all costs associated with said Acceptance. The Contractor is also responsible for preparation, re-submission and payment of any and all updated certificates.
- 29.06 Retainage monies, minus those funds deducted in accordance to the requirements of this agreement including but not limited to Paragraph 28.10, shall be due Contractor not earlier than forty-six (46) calendar days after recordation of certificate of Owner's acceptance provided the following:
- (1) Contractor shall prepare, secure, pay for and submit clear lien and privilege certificate, signed and sealed by Clerk of Court or Recorder of Mortgages, Parish of St. Tammany and dated at least forty-six (46) days after recordation of certificate of acceptance;
 - (2) Ensure that the official representative of the Owner has accepted as per LSA-R.S. 38:2241.1, *et seq.* and that all following sub-sections have been properly satisfied as per law;
 - (3) Ensure that all signatures are affixed and that there exists the requisite authority for all signatures;
 - (4) Ensure accurate and proper legal descriptions;
 - (5) Properly identify all parties and/or signatories;
 - (6) Properly identify all mailing addresses;
 - (7) Correctly set for the amount of the contract, together with all change orders;
 - (8) Set out a brief description of the work performed;
 - (9) Reference to any previously recorded contract, lien or judgment inscription that may affect the property;
 - (10) Certification that substantial completion has occurred, together with any

applicable date(s);

- (11) Certification that no party is in default and/or that the project has been abandoned.

29.07 After securing the clear lien and privilege certificate the Contractor shall prepare its final application for payment and submit to Owner. The Owner shall approve application for payment, or state its objections in writing and forward to Contractor for resolution.

30.00 NOTICE AND SERVICE THEREOF

30.01 Any Notice to Contractor from the Owner relative to any part of this Contract shall be in writing and shall be considered delivered and the service thereof completed when said notice is posted; by certified mail, return receipt requested to the said Contractor at its last given address, or delivered in person to said Contractor or its authorized representative on the Work.

31.00 INTENTION OF THESE GENERAL CONDITIONS

31.01 These General Conditions shall be applicable to all contracts entered into by and between the Owner and Contractors, except as may be altered or amended with the consent of the Owner, and/or provided for in the Special Conditions of each contract. Contractor shall be presumed to have full knowledge of these General Conditions which shall be applicable to all contracts containing these General Conditions, whether Contractor has obtained a copy thereof or not.

32.00 SEVERABILITY

32.01 If any one or more or part of any of the provisions contained herein and/or in the Specifications and Contract for the Work shall for any reason be held invalid, illegal or unenforceable in any respect, such invalidity, illegality or unenforceability shall not affect any other provisions of this Agreement or attachment, but it shall be construed as if such invalid, illegal, or unenforceable provision or part of a provision had never been contained herein.

32.02 **CHANGING THESE CONDITIONS:** Owner reserves the right to change or modify these General Conditions as it deems best, or as required by law. The General Conditions may also be modified for a particular project by the use of Special Conditions prior to the issuance of the Advertisement for Bid. However, once an advertisement for bid is made for any specific project, any changes to the General Conditions as they affect that specific project must be made in writing and issued via an addendum in accordance with State Law.

33.00 LAW OF THE STATE OF LOUISIANA

33.01 The Contract Documents shall be governed by the Law of the State of Louisiana.

33.02 The Contractor agrees to pay reasonable attorney's fees and other reasonable attendant costs, in the event that it becomes necessary for the Owner to employ an attorney in order to enforce compliance with or any remedy relating to any covenants, obligations, or conditions imposed upon the Contractor by this Agreement. Attorney fees shall be based upon the prevailing hourly rate of attorney rates in the private sector. In no case shall the hourly rate be less than \$175.00 per hour. All attorney fees collected shall be paid the operating budget of the Office of the Parish President.

33.03 The jurisdiction and venue provisions shall apply to all contractors, sureties, and subcontractors. The 22nd Judicial District for the Parish of St. Tammany shall be the court of exclusive jurisdiction and venue for any dispute arising from these General Conditions and/or any contract executed in conjunction with these General Conditions. All parties specifically waive any rights they have or may have for removal of any disputes to Federal Court, or transfers to different State District Court.

- 33.04 Contractor warrants that it has and/or had received a copy of these General Conditions at all times material hereto; Contractor further agrees that it has read and fully and completely understands each and every condition herein.
- 33.05 The property description will be more fully set out by an attached exhibit.
- 33.06 The Contractor warrants that it has the requisite authority to sign and enter this agreement.
- 33.07 It is specifically understood and agreed that in the event Contractor seeks contribution from the Parish or pursues its legal remedies for any alleged breach of this agreement by the Parish, then the following list of damages SHALL NOT BE RECOVERABLE BY CONTRACTOR. This list includes, but is not limited to:
1. indirect costs and/or expenses;
 2. direct costs and/or expenses;
 3. time-related costs and/or expenses;
 4. award of extra days;
 5. costs of salaries or other compensation of Contractor's personnel at Contractor's principal office and branch offices;
 6. expenses of Contractor's principal, branch and/or field offices;
 7. any part of Contractor's capital expenses, including any interest on Contractor's capital employed for the work;
 8. any other charges related to change orders;
 9. overhead and general expenses of any kind or the cost of any item not specifically and expressly included in Cost of Work.

33.08 DEFAULT AND WAIVERS

It is understood that time is of the essence. It is specifically understood between the parties that Contractor waives any and all notice to be placed in default by the Owner. This subsection shall supersede and prime any other subsection herein above that is in conflict. The Owner specifically reserves its right and specifically does not waive the requirement to be placed in default by the Contractor as per law.

- 33.09 St. Tammany Parish Government contracts to be awarded are dependent on the available funding and/or approval by members designated and/or acknowledged by St. Tammany Parish Government. At any time St. Tammany Parish Government reserves the right to cancel the award of a contract if either or both of these factors is deficient.
- 33.10 It is the Parish's policy to provide a method to protest exclusion from a competition or from the award of a contract, or to challenge an alleged solicitation irregularity. It is always better to seek a resolution within the Parish system before resorting to outside agencies and/or litigation to resolve differences. All protests must be made in writing, and shall be concise and logically presented to facilitate review by the Parish. The written protest shall include:
1. The protester's name, address, and fax and telephone numbers and the solicitation, bid, or contract number;
 2. A detailed statement of its legal and factual grounds, including a description of the resulting prejudice to the protester;
 3. Copies of relevant documents;
 4. All information establishing that the protester is an interested party and that the protest is timely; and
 5. A request for a ruling by the agency; and a statement of the form of relief requested.

The protest shall be addressed to Director of Procurement, St. Tammany Parish Government, P.O. Box 628, Covington, LA 70434.

The protest review shall be conducted by the Parish Procurement Department.

Only protests from interested parties will be allowed. Protests based on alleged solicitation improprieties that are apparent before bid opening, or the time set for receipt of initial proposals must be filed with and received by the Procurement Department BEFORE those deadlines.

Any other protest shall be filed no later than ten (10) calendar days after the basis of the protest is known, or should have been known (whichever is earlier).

The Parish will use its best efforts to resolve the protest within thirty (30) days of the date that it is received by the Parish. The written response will be sent to the protestor via mail and, fax, if a fax number has been provided by the protestor. The protester can request additional methods of notification.

Last day to submit questions and/or verification on comparable products will be no later than 2:00 pm CST, seven (7) working days prior to the opening date of the bid/proposal due date. Further any questions or inquires must be submitted via fax to 985-898-5227, or via email to Procurement@stpgov.org. Any questions or inquires received after the required deadline to submit questions or inquires will not be answered.

CORPORATE RESOLUTION

EXCERPT FROM MINUTES OF MEETING OF THE BOARD OF DIRECTORS OF INCORPORATED.

AT THE MEETING OF DIRECTORS OF _____ INCORPORATED, DULY NOTICED AND HELD ON _____, A QUORUM BEING THERE PRESENT, ON MOTION DULY MADE AND SECONDED. IT WAS:

RESOLVED THAT _____, BE AND IS HEREBY APPOINTED, CONSTITUTED AND DESIGNATED AS AGENT AND ATTORNEY-IN-FACT OF THE CORPORATION WITH FULL POWER AND AUTHORITY TO ACT ON BEHALF OF THIS CORPORATION IN ALL NEGOTIATIONS, BIDDING, CONCERNS AND TRANSACTIONS WITH THE PARISH OF ST. TAMMANY OR ANY OF ITS AGENCIES, DEPARTMENTS, EMPLOYEES OR AGENTS, INCLUDING BUT NOT LIMITED TO, THE EXECUTION OF ALL BIDS, PAPERS, DOCUMENTS, AFFIDAVITS, BONDS, SURETIES, CONTRACTS AND ACTS AND TO RECEIVE ALL PURCHASE ORDERS AND NOTICES ISSUED PURSUANT TO THE PROVISIONS OF ANY SUCH BID OR CONTRACT, THIS CORPORATION HEREBY RATIFYING, APPROVING, CONFIRMING, AND ACCEPTING EACH AND EVERY SUCH ACT PERFORMED BY SAID AGENT AND ATTORNEY-IN-FACT.

I HEREBY CERTIFY THE FOREGOING TO BE A TRUE AND CORRECT COPY OF AN EXCERPT OF THE MINUTES OF THE ABOVE DATED MEETING OF THE BOARD OF DIRECTORS OF SAID CORPORATION, AND THE SAME HAS NOT BEEN REVOKED OR RESCINDED.

SECRETARY-TREASURER

DATE

Certificate of Insurance Instructions

The below information is intended to guide Contractors on what information is needed to be listed on the Certificate of Insurance. All Insurance limit requirements can be found in Attachment D.

- **Certificate Holder** – STPG must be listed as the certificate holder, and it must include our address of: P.O. Box 628, Covington, LA 70434
 - Reason: the certificate holder is where cancellations of coverage, or updated certificates are mailed. If a vendor terminates a policy, we will be notified.
- **Additional Insured** – We must be named as an additional insured so that if there is a lawsuit against the vendor for a project, their coverage will cover STPG as well if we are named in the lawsuit.
 - We must be named in the Description of Operations box – reason: there could be other additional insureds, and we want to have no doubt that we are one of the additional insureds.
 - We must be named as additional insured on the following coverages: General liability, Auto Liability, Umbrella/Excess Liability, Environmental/Pollution Liability.
 - Professional Liability policies do not allow for an additional insured by most carriers.
- **Project Name & Contract #** - We need this listed in the Description of Operations, again so that if there is a lawsuit, we have proof that coverage was active for that project.
- **Waiver of Subrogation** – This can either be listed in the Description of Operations or checked off in the appropriate columns.

From the Insurance Requirement form:

Waiver of Subrogation: The Provider's insurers will have no right of recovery or subrogation against the Parish of St. Tammany, it being the intention of the parties that all insurance policy(ies) so affected shall protect both parties and be the primary coverage for any and all losses covered by the below described insurance.

- **Owners Protective Liability (OPL) or (OCP)** – Certificate of Insurance for OCP names St. Tammany Parish Government as the Insured and the Certificate Holder.
- Sample of Certificate of Insurance (COI) can be found on page 2.
- Please refer to this section in the package labeled “Insurance Requirements” for limits required for this project

Any questions regarding insurance requirements please contact the Risk Department at 985-898-5226 or email riskman@stpgov.org



CERTIFICATE OF LIABILITY INSURANCE

DATE (MM/DD/YYYY)

THIS CERTIFICATE IS ISSUED AS A MATTER OF INFORMATION ONLY AND CONFERS NO RIGHTS UPON THE CERTIFICATE HOLDER. THIS CERTIFICATE DOES NOT AFFIRMATIVELY OR NEGATIVELY AMEND, EXTEND OR ALTER THE COVERAGE AFFORDED BY THE POLICIES BELOW. THIS CERTIFICATE OF INSURANCE DOES NOT CONSTITUTE A CONTRACT BETWEEN THE ISSUING INSURER(S), AUTHORIZED REPRESENTATIVE OR PRODUCER, AND THE CERTIFICATE HOLDER.

IMPORTANT: If the certificate holder is an ADDITIONAL INSURED, the policy(ies) must be endorsed. If SUBROGATION IS WAIVED, subject to the terms and conditions of the policy, certain policies may require an endorsement. A statement on this certificate does not confer rights to the certificate holder in lieu of such endorsement(s).

PRODUCER	CONTACT NAME:	
	PHONE (A/C, No. Ext):	FAX (A/C, No):
	E-MAIL ADDRESS:	
	INSURER(S) AFFORDING COVERAGE	NAIC #
INSURED	INSURER A :	
	INSURER B :	
	INSURER C :	
	INSURER D :	
	INSURER E :	
	INSURER F :	

COVERAGES

CERTIFICATE NUMBER:

REVISION NUMBER:

THIS IS TO CERTIFY THAT THE POLICIES OF INSURANCE LISTED BELOW HAVE BEEN ISSUED TO THE INSURED NAMED ABOVE FOR THE POLICY PERIOD INDICATED. NOTWITHSTANDING ANY REQUIREMENT, TERM OR CONDITION OF ANY CONTRACT OR OTHER DOCUMENT WITH RESPECT TO WHICH THIS CERTIFICATE MAY BE ISSUED OR MAY PERTAIN, THE INSURANCE AFFORDED BY THE POLICIES DESCRIBED HEREIN IS SUBJECT TO ALL THE TERMS, EXCLUSIONS AND CONDITIONS OF SUCH POLICIES. LIMITS SHOWN MAY HAVE BEEN REDUCED BY PAID CLAIMS.

INSR LTR	TYPE OF INSURANCE	ADDL INSR	SUBR WVD	POLICY NUMBER	POLICY EFF (MM/DD/YYYY)	POLICY EXP (MM/DD/YYYY)	LIMITS
	GENERAL LIABILITY						EACH OCCURRENCE \$
	<input type="checkbox"/> COMMERCIAL GENERAL LIABILITY						DAMAGE TO RENTED PREMISES (Ea occurrence) \$
	<input type="checkbox"/> CLAIMS-MADE <input type="checkbox"/> OCCUR						MED EXP (Any one person) \$
							PERSONAL & ADV INJURY \$
							GENERAL AGGREGATE \$
	GEN'L AGGREGATE LIMIT APPLIES PER:						PRODUCTS - COMP/OP AGG \$
	<input type="checkbox"/> POLICY <input type="checkbox"/> PRO-JECT <input type="checkbox"/> LOC						\$
	AUTOMOBILE LIABILITY						COMBINED SINGLE LIMIT (Ea accident) \$
	<input type="checkbox"/> ANY AUTO						BODILY INJURY (Per person) \$
	<input type="checkbox"/> ALL OWNED AUTOS	<input type="checkbox"/>	<input type="checkbox"/>				BODILY INJURY (Per accident) \$
	<input type="checkbox"/> HIRED AUTOS	<input type="checkbox"/>	<input type="checkbox"/>				PROPERTY DAMAGE (Per accident) \$
		<input type="checkbox"/>	<input type="checkbox"/>				\$
	UMBRELLA LIAB						EACH OCCURRENCE \$
	<input type="checkbox"/> EXCESS LIAB						AGGREGATE \$
	<input type="checkbox"/> OCCUR						\$
	<input type="checkbox"/> CLAIMS-MADE						
	DED						
	RETENTION \$						
	WORKERS COMPENSATION AND EMPLOYERS' LIABILITY						WC STATUTORY LIMITS
	ANY PROPRIETOR/PARTNER/EXECUTIVE OFFICER/MEMBER EXCLUDED? (Mandatory in NH)						OTHER
	If yes, describe under DESCRIPTION OF OPERATIONS below	<input type="checkbox"/> Y / N	<input type="checkbox"/> N / A				E.L. EACH ACCIDENT \$
							E.L. DISEASE - EA EMPLOYEE \$
							E.L. DISEASE - POLICY LIMIT \$

DESCRIPTION OF OPERATIONS / LOCATIONS / VEHICLES (Attach ACORD 101, Additional Remarks Schedule, if more space is required)

Project Name:
Contract #:

(Name St. Tammany Parish Government as an additional insured).

CERTIFICATE HOLDER**CANCELLATION**St. Tammany Parish Government
P.O. Box 628
Covington, LA 70434

SHOULD ANY OF THE ABOVE DESCRIBED POLICIES BE CANCELLED BEFORE THE EXPIRATION DATE THEREOF, NOTICE WILL BE DELIVERED IN ACCORDANCE WITH THE POLICY PROVISIONS.

AUTHORIZED REPRESENTATIVE

Bond No.: _____

**CONTRACT AGREEMENT
BETWEEN PARISH AND CONTRACTOR**

BY: ST. TAMMANY PARISH GOVERNMENT

**UNITED STATES OF
AMERICA**

WITH:

**STATE OF LOUISIANA
ST. TAMMANY PARISH**

This agreement is entered into this _____ day of _____, 20____, by and between: «txtREQCompanyName», hereinafter called the "Contractor", whose business address is «txtREQAddress», «txtREQCity», «txtREQState» «txtREQZip» and the St. Tammany Parish Government, hereinafter called the "Parish", whose business address is P.O. Box 628, Covington, LA 70434 (collectively, the "Parties") for «txtPROJECTNAME» project. Witnessed that the Contractor and the Parish, in consideration of premises and the mutual covenants, consideration and agreement herein contained, agree as follows:

1. SCOPE OF SERVICES

The Contractor shall furnish all labor and materials and perform all of the work required to build, construct and/or complete in a thorough and workmanlike manner:

«txtScopeSummary»

2. CONSTRUCTION DOCUMENTS

It is recognized by the Parties herein that said Construction Documents, including by way of example and not of limitation, the plans and Specifications, General Conditions, Supplementary General Conditions, any addenda thereto, the drawings (if any), and the bid, quote or other procurement documents impose duties and obligations upon the Parties herein, and said Parties thereby agree that they shall be bound by said duties and obligations. For these purposes, all of the provisions contained in the aforementioned Construction Documents are incorporated herein by reference with the same force and effect as though said Construction Documents were herein set out in full. Copies of the aforementioned Construction Documents are in the possession of both the Contractor and the Parish for reference.

3. TIME FOR COMPLETION

The work shall be commenced on a date to be specified in a written order of the Parish and shall be completed within «intCompletionTime» calendar days from and after said date.

4. COMPENSATION TO BE PAID TO THE CONTRACTOR

The Parish will pay and the Contractor will accept in full consideration for the performance of the Contract the sum of «curREQGrandTotal» dollars.

5. PERFORMANCE AND PAYMENT BOND

To these presents personally came and intervened _____,
(Name of Attorney in Fact)
herein acting for _____, a corporation organized
(Surety)
and existing under the laws of the State of _____, and duly authorized to transact business in the State of Louisiana, as surety, who declared that having taken cognizance of this Contract and of the Construction Documents mentioned herein, he hereby in his capacity as its Attorney in Fact obligates his company, as surety for the said Contractor, unto the said Parish, up to the sum of «curREQGrandTotal». The condition of this performance and payment bond

shall be that should the Contractor herein not perform the Contract in accordance with the terms and conditions hereof, or should said Contractor not fully indemnify and save harmless the Parish from all costs and damages which he may suffer by said Contractor's non-performance or should said Contractor not pay all persons who have fulfilled obligations to perform labor and/or furnish materials in the prosecution of the work provided for herein, including by way of example, workmen, laborers, mechanics, and furnishers of materials, machinery, equipment and fixtures, then said surety agrees and is bound to so perform the Contract and make said payment(s).

Contractor and Parish specifically agree to and recognize (1) the statutory employer relationship existing between the Parish and any employees performing work under this Contract as employees of the Contractor or employees of the "Sub-Contractor", and (2) that the work performed by the employees of the Contractor and the employees of the "Sub-Contractor" is part of the Parish's business, occupation or trade and is essential to the ability of the Parish to generate their products or services, all of which is in accordance with LSA-R.S. 23:1061, and as may be amended.

6. LIABILITY AND INDEMNIFICATION

A. Duty to Defend

Upon notice of any claim, demand, suit, or cause of action against the Parish, alleged to arise out of or be related to this Contract, Contractor shall investigate, handle, respond to, provide defense for, and defend at its sole expense, even if the claim, demand, suit, or cause of action is groundless, false, or fraudulent. The Parish may, but is not required to, consult with or assist the Contractor, but this assistance shall not affect the Contractor's obligations, duties, and responsibilities under this section. Contractor shall obtain the Parish's written consent before entering into any settlement or dismissal.

B. Contractor Liability

Contractor shall be liable without limitation to the Parish for any and all injury, death, damage, loss, destruction, damages, costs, fines, penalties, judgments, forfeitures, assessments, expenses (including attorney fees), obligations, and other liabilities of every name and description, which may occur or in any way arise out of any act or omission of Contractor, its owners, agents, employees, partners or subcontractors.

C. Force Majeure

It is understood and agreed that neither party can foresee the exigencies beyond the control of each party which arise by reason of an Act of God or force majeure; therefore, neither party shall be liable for any delay or failure in performance beyond its control resulting from an Act of God or force majeure. The Parish shall determine whether a delay or failure results from an Act of God or force majeure based on its review of all facts and circumstances. The parties shall use reasonable efforts, including but not limited to, use of continuation of operations plans (COOP), business continuity plans, and disaster recovery plans, to eliminate or minimize the effect of such events upon the performance of their respective duties under this Contract.

D. Indemnification

Contractor shall fully indemnify and hold harmless the Parish, without limitation, for any and all injury, death, damage, loss, destruction, damages, costs, fines, penalties, judgments, forfeitures, assessments, expenses (including attorney fees), obligations, and other liabilities of every name and description, which may occur or in any way arise out of any act or omission of Contractor, its

owners, agents, employees, partners or subcontractors. The Contractor shall not indemnify for the portion of any loss or damage arising from the Parish's act or failure to act.

E. Intellectual Property Indemnification

Contractor shall fully indemnify and hold harmless the Parish, without limitation, from and against damages, costs, fines, penalties, judgments, forfeitures, assessments, expenses (including attorney fees), obligations, and other liabilities in any action for infringement of any intellectual property right, including but not limited to, trademark, trade-secret, copyright, and patent rights.

When a dispute or claim arises relative to a real or anticipated infringement, the Contractor, at its sole expense, shall submit information and documentation, including formal patent attorney opinions, as required by the Parish.

If the use of the product, material, service, or any component thereof is enjoined for any reason or if the Contractor believes that it may be enjoined, Contractor, while ensuring appropriate migration and implementation, data integrity, and

minimal delays of performance, shall at its sole expense and in the following order of precedence: (i) obtain for the Parish the right to continue using such product, material, service, or component thereof; (ii) modify the product, material, service, or component thereof so that it becomes a non-infringing product, material, or service of at least equal quality and performance; (iii) replace the product, material, service, or component thereof so that it becomes a non-infringing product, material, or service of at least equal quality and performance; or, (iv) provide the Parish monetary compensation for all payments made under the Contract related to the infringing product, material, service, or component, plus for all costs incurred to procure and implement a non-infringing product, material, or service of at least equal quality and performance. Until this obligation has been satisfied, the Contractor remains in default.

The Contractor shall not be obligated to indemnify that portion of a claim or dispute based upon the Parish's unauthorized: i) modification or alteration of the product, material or service; ii) use of the product, material or service in combination with other products not furnished by Contractor; or, iii) use of the

product, material or service in other than the specified operating conditions and environment.

7. MODIFICATION OF CONTRACT TERMS

Provided that any alterations which may be made in the terms of the Contract or in the work to be done under it, or the giving by the Parish of any extensions of time for the performance of the Contract, or any other forbearance on the part of either the Parish or the Contractor to the other shall not in any way release the Contractor or the Surety from their liability hereunder, notice to the Surety of any such alterations, extensions or other forbearance being hereby waived.

8. TERMINATION, CANCELLATION, AND SUSPENSION

A. Termination

The term of this Contract shall be binding upon the Parties hereto until the work has been completed by the Provider and accepted by the Parish, and all payments required to be made to the Provider have been made. But, this Contract may be terminated upon thirty (30) days written notice under any or all of the following conditions:

- 1) By mutual agreement and consent of the Parties hereto;
- 2) By the Parish as a consequence of the failure of the Provider to comply with the terms, progress, or quality of the work in a satisfactory manner, proper allowances being made for circumstances beyond the control of the Provider;
- 3) By either party upon failure of the other party to fulfill its obligations as set forth in this Contract;
- 4) By the Parish with less than thirty (30) days' notice due to budgetary reductions and changes in funding priorities by the Parish;
- 5) In the event of the abandonment of the project by the Parish.

Upon termination, the Provider shall be paid for actual work performed prior to the Notice of Termination, either based upon the established hourly rate for services actually performed, or on a pro-rata share of the basic fee based upon the phase or percentage of work actually completed, depending on the type of compensation previously established under this Contract.

Upon Termination, the Provider shall deliver to the Parish all original documents, notes, drawings, tracings, computer files, and other files pertaining to this Contract or the Work performed, except for the Provider's personal and administrative files.

B. Cancellation

The continuation of this Contract is contingent upon the appropriation of funds to fulfill the requirements of the Contract by the Parish. If the Parish fails to appropriate sufficient monies to provide for the continuation of this or any other Contract, or if such appropriation is reduced by the veto of Parish President by any means provided in the appropriations Ordinance to prevent the total appropriation for the year from exceeding revenues for that year, or for any other lawful purpose, and the effect of such reduction is to provide insufficient monies for the continuation of the Contract, the Contract shall terminate on the date of the beginning of the first fiscal year for which funds are not appropriated. It is understood and agreed that paragraph (9)(C) below may preempt this paragraph, all at the exclusive and unilateral option of the Parish.

C. Suspension

Should the Parish desire to suspend the work, but not definitely terminate the Contract, the Parish shall supply the Provider with thirty (30) days' notice. The Parish will also

supply Provider thirty (30) days' notice that the work is to be reinstated and resumed in full force. Provider shall receive no additional compensation during the suspension period. The Parties may revisit the terms of this Contract during the suspension period. The suspension shall not exceed six (6) months, unless mutually agreed upon between the Parties.

- D.** Failure to complete or deliver within the time specified or to provide the services as specified in the bid or response will constitute a default and may cause cancellation of the contract. Where the Parish has determined the contractor to be in default. The Parish reserves the right to purchase any or all products or services covered by the contract on the open market and to charge the contractor with the cost in excess of the contract price. Until such assessed charges have been paid, no subsequent bid or response from the defaulting contractor will be considered.
- E.** In the event of a default and/or breach of this agreement and this matter is forwarded to legal counsel, then the prevailing party may be entitled to collect a reasonable attorney fees and all costs associated therewith whether or not litigation is initiated. Attorney fees shall be based upon the current, reasonable prevailing rate for counsel in the private

sector. The Parties agree to be responsible for such attorney fees, together for all with legal interest from date of agreement breach, plus all costs of collection.

- F.** Termination or cancellation of this agreement will not affect any rights or duties arising under any term or condition herein.

- G.** As to the filing of voluntary or involuntary bankruptcy by Provider, Provider agrees that if any execution or legal process is levied upon its interest in this Contract, or if any liens or privileges are filed against its interest, or if a petition in bankruptcy is filed against it, or if it is adjudicated bankrupt in involuntary proceedings, or if it should breach this Contract in any material respect, the Parish shall have the right, at its unilateral option, to immediately cancel and terminate this Contract. In the event that Provider is placed in any chapter of bankruptcy, voluntarily or involuntarily, or otherwise triggers any provision of the preceding sentence herein, it is understood and agreed that all materials, goods and/or services provided shall be and remain the property of the Parish. All rights of Provider as to goods, wares, products, services, materials and the like supplied to Parish shall be deemed forfeited.

9. RECORDATION OF CONTRACT

Contractor authorizes Parish to deduct from any payment due herein costs and service fees for recordation of this Contract in full or an excerpt hereof, or any revisions or modifications thereof as required by law.

10. AUTHORITY TO ENTER CONTRACT

The undersigned representative of Contractor warrants and personally guarantees that he/she has the requisite and necessary authority to enter and sign this Contract on behalf of the corporate entity, partnership, etc. The undersigned Parties warrant and represent that they each have the respective authority and permission to enter this Contract. In the event that Contractor is a member of a corporation, partnership, L.L.C., L.L.P., or any other juridical entity, the Parish requires, as an additional provision, that Contractor supply a certified copy of a corporate resolution authorizing the undersigned to enter and sign this Contract. Another option to fulfill this additional provision he/she can supply Louisiana Secretary of State Business filings confirming that he/she is a managing member of a

corporation, partnership, L.L.C., L.L.P., or any other juridical entity which authorizes the undersigned to enter and sign this Contract.

In Witness thereof, the Parties hereto on the day and year first above written have executed this Contract in One (1) counterparts, each of which shall, without proof or accountancy for the other counterparts, be deemed an original thereof.

WITNESSES:

CONTRACTOR:

Signature

Signature

Print Name

Print Name

Signature

Title

Print Name

Date

Bond No.: _____

WITNESSES:

**ST. TAMMANY PARISH
GOVERNMENT:**

Signature

Print Name

Signature

Print Name

Michael B. Cooper
Parish President

Date

APPROVED BY:

Assistant District Attorney- Civil (Surety)
Division

Signature

Date

Print Name

SECTION 12

TECHNICAL SPECIFICATIONS

TABLE OF CONTENTS

<u>SPECIFICATION</u>	<u>PAGE NUMBER</u>
SECTION 01010 – SUMMARY OF WORK.....	01010-1 thru 1010-2
SECTION 01025 – MEASUREMENT AND PAYMENT.....	01025-1 thru 01025-6
SECTION 01050 – FIELD ENGINEERING & SURVEYING	01050-1 thru 01050-2
SECTION 01152 – REQUESTS FOR PAYMENT	01152-1 thru 01152-3
SECTION 01153 – CHANGE ORDER PROCEDURES.....	01153-1 thru 01153-4
SECTION 01200 – PROJECT MEETINGS.....	01200-1 thru 01200-4
SECTION 01310 – CONSTRUCTION SCHEDULING.....	01310-1 thru 01310-8
SECTION 01340 – SHOP DRAWINGS, PRODUCT DATA, AND SAMPLES.....	01340-1 thru 01340-6
SECTION 01350 – VIBRATION MONITORING.....	01350-1 thru 01350-5
SECTION 01380 – CONSTRUCTION PHOTOS & VIDEOS.....	01380-1 thru 01380-4
SECTION 01410 – TESTING LAB SERVICES	01410-1 thru 01410-3
SECTION 01600 – MATERIAL & EQUIPMENT.....	01600-1 thru 01600-3
SECTION 01700 – CONTRACT CLOSEOUT	01700-1 thru 01700-3
SECTION 01720 – PROJECT RECORD DOCUMENTS	01720-1 thru 01720-2
SECTION 01740 – WARRANTIES & BONDS.....	01740-1 thru 01740-2

SECTION 02140 – MOBILIZATION	02140-1 thru 02140-2
SECTION 02240 –GEOTEXTILE FABRIC.....	02240-1 thru 02240-4
SECTION 02270 – RIP RAP	02270-1 thru 02270-3
SECTION 02272 – GEOGRID	02272-1 thru 02273-3
SECTION 02315 – DREDGING, FILL, & GRADING.....	02315-1 thru 02315-4
SECTION 02480 – MARINE HAZARD MARKERS.....	02480-1 thru 02480-2
SECTION 05500 –METAL FABRICATIONS.....	05500-1 thru 0550-3
SECTION 06100 – ROUGH CARPENTRY.....	06100-1 thru 06100-4
SECTION 06200 – DRIVEN PILES	06200-1
SECTION 06300 – TREATED TIMBER.....	06300-1
SECTION 06400 – PIER CONSTRUCTION	06400-1
SECTION 06500 – SHEET PILES	06500-1 thru 06500-2
SECTION 06610 – MOLDED MESH GRATING	06610-1 thru 06610-5

SECTION 01010

SUMMARY OF WORK

PART 1 - GENERAL

1.01 WORK COVERED BY CONTRACT DOCUMENTS/REQUIREMENTS INCLUDED

- A. The work of this contract includes the construction of a pier 300' in length, construction of a rock breakwater approximately 400 feet in length, and construction of a vinyl sheet pile bulkhead around the existing peninsula of the Tchefuncte River Lighthouse.
- B. The Contractor shall furnish all labor, materials, equipment, tools, services, and incidentals to complete all work required by these specifications and as shown on the drawings.
- C. The Contractor shall perform the work complete, in place and ready for continuous service, and shall include repairs, replacements, and restoration required as a result of damages caused during this construction.
- D. The Contractor shall furnish and install all materials, equipment, and labor which is reasonably and properly inferable and necessary for the proper completion of the work, whether specifically indicated in the Contract Documents or not.

1.02 CONTRACTS

The Contract consists of a unit bid price. The Bidder shall complete the schedule of all unit prices included in the Bid Form and shall accept all fixed unit prices listed therein. The total Bid will be determined as the sum of the products of the estimated quantity of each item and the unit price bid. The final Contract Price will be subject to adjustment according to final measured, used, or delivered quantities as provided in Division 1, and the unit prices in the bid will apply to such final quantities except that unit prices will be subject to change by Change Order if quantities vary more than twenty-five percent (25%).

1.03 WORK SEQUENCE

- A. Work Sequence shall be at the discretion of the contractor.

1.04 CONSTRUCTION AREAS

- A. Contractor shall limit his use of the construction areas for work and storage to allow for:

- 1) Commercial Use.
- 2) Owner use.
- 3) Public use.

- B. Coordinate use of work site under direction of Engineer.
- C. Assume full responsibility for the protection and safekeeping of products under this contract, stored on the site.
- D. Move any stored products, under Contractor's control, which interfere with operations of the Owner or separate contractor.
- E. Obtain and pay for the use of additional storage or work areas needed for operations.

1.05 OWNER OCCUPANCY

- A. Contractor shall at all times conduct his operations as to insure the least inconvenience to the general public.

PART 2 - PRODUCTS (NOT USED)

PART 3 - EXECUTION (NOT USED)

END OF SECTION

SECTION 01025

MEASUREMENT AND PAYMENT

PART 1 – GENERAL

- A. Refer to Proposal Form
- B. Payment shall include all compensation to be received by the Contractor for furnishing all tools, equipment, supplies, and manufactured articles, and for all labors, operations, and incidentals appurtenant to complete the work being described, as necessary to complete the various items of the work all in accordance with the requirement of the Contract Documents, including all costs of compliance with the regulations of public agencies having jurisdiction. The Contractor is hereby on notice that no separate payment will be made for any item not specifically called out, but that is required to properly complete the project.

PART 2 – PRODUCTS (NOT USED)

PART 3 – EXECUTION (NOT USED)

PART 4 – MEASUREMENT AND PAYMENT

4.01 SCOPE

The Total Bid Price shall cover all work required by the Contract Documents. All costs in connection with the proper and successful completion of the work, including furnishing all materials, equipment, supplies, and appurtenances; providing all construction equipment, and tools; and performing all necessary labor and supervision to fully complete the work, shall be included in the unit and lump sum prices bid. All work not specifically set forth as a pay item in the Bid Form shall be considered a subsidiary obligation of the Contractor and all costs in connection therewith shall be included in the prices bid.

4.02 ESTIMATED QUANTITIES

All estimated quantities stipulated in the Bid Form or other Contract Documents are approximate and are to be used only (a) as a basis for estimating the probable cost of the work, and (b) for the purpose of comparing the bids submitted for the work. The actual amounts of work done and materials furnished under unit price items may differ from the estimated quantities. The basis of payment for work and materials will be the actual amount of work done and materials furnished. No compensation will be given for any quantities not used.

4.03 BASE BID MOBILIZATION (ITEM 1)

- A. Measurement: Measurement for payment for mobilization and demobilization will be on a lump-sum basis as specified herein.
- B. Payment: Payment for mobilization and demobilization shall cover all preparatory work, obtaining all permits, insurance and bonds, movement of personnel, equipment, supplies and incidentals to the project site, preconstruction photographs and videos, the establishment of temporary offices, magnetometer survey, and other construction facilities necessary for work on this project. It shall include removal of all personnel, equipment, supplies and incidentals from the project site, removal of temporary offices and other construction facilities necessary for work on this project, all as required for the proper performance and completion of the work. Payment will be made at the contract lump sum price, subject to the following provisions:

Partial payments for mobilization and demobilization will be made in accordance with the following schedule up to a maximum of 10 percent of the total contract amount (including this item), and payment of any remaining amount will be made upon completion of all work under the contract.

<u>Percent of Total Contract Amount Earned</u>	<u>Allowable Percent of the Lump Sum Price for the Item</u>
1 st Partial Estimate	25%
10%	50%
25%	75%
50%	100%

No price adjustments will be made for this item due to changes in the work.

4.04 VINYL SHEETPILE (ITEM 2)

- A. Measurement: Vinyl Sheetpile will be measured per the square foot in-place for Bid Item 11, Vinyl Sheetpile.
- B. Payment: Payment for this item will be made at the contract unit price per square foot in-place. Price and payment shall constitute full compensation for furnishing all labor, materials, and equipment for construction and maintenance of all required sheet piles and performing all work specified herein. No payment shall be made for Sheet Piling that are rejected or damaged due to fault or negligence by the Contractor.

4.05 GEOTEXTILE (ITEMS 3 & 9)

- A. Measurement: Geotextile will be measured in place to the nearest square yard of protected area as delineated on the drawings. Overlaps will be measured as a single layer.

- B. Payment: Payment will be made at the applicable contract unit price for "Geotextile Fabric" per square yard. Price and payment shall constitute full compensation for providing all plant, labor, material, and equipment and performing all operations necessary for the complete and satisfactory installation of the geotextile. No payment shall be made for geotextile that is rejected or damaged due to CONTRACTOR fault or negligence.

4.06 GEOGRID (ITEMS 4 & 10)

- A. Measurement: Geogrid will be measured in place to the nearest square yard of protected area as delineated on the drawings. Overlaps will be measured as a single layer.
- B. Payment: Payment will be made at the applicable contract unit price for "Geogrid" per square yard. Price and payment shall constitute full compensation for providing all plant, labor, material, and equipment and performing all operations necessary for the complete and satisfactory installation of the geogrid. No payment shall be made for geogrid that is rejected or damaged due to CONTRACTOR fault or negligence.

4.07 DREDGING, FILL, AND GRADING (ITEM 5)

- A. Dredging, Fill, and Grading will be paid for at the lump sum price for "Dredging, Fill and Grading". Price and payment shall constitute full compensation for all materials, labor, supplies, and equipment required for dredging approximately 250 cubic yards of material from the permitted dredge area shown on the plans and placing to on the peninsula to the lines and grades shown on the plans.

Any flotation channel dredging required for access to the site beyond the fill required in the base bid shall be considered incidental to the contractor's mobilization cost for any base bid or alternate.

4.08 RIP RAP R200 (ITEM 6)

- A. Measurement: Rip-rap shall be measured by the ton (2,000 pounds). Quantities will be computed to the nearest tenth of a ton. If rip-rap is delivered by truck, measurement will be based on certified weight tickets furnished to the ENGINEER by the CONTRACTOR. If rip-rap is delivered by barge, measurement will be made by calculation from barge displacement in a manner acceptable to the ENGINEER, based on water 62.4 pounds per cubic foot.
- B. Payment: Rip-rap will be paid for at the contract unit prices per ton. Price and Payment shall include all costs of furnishing, hauling, handling and placing to the lines and grades as shown on the plans.

4.09 PILE REMOVAL (ITEM 7)

- A. Measurement and payment for removal of existing timber piles will be per each timber pile removed under Item 7 – PILE REMOVAL.

4.10 ALTERNATE 1 MOBILIZATION (ITEM 8)

- A. Measurement: Measurement for payment for mobilization and demobilization will be on a lump-sum basis as specified herein.
- B. Payment: Payment for mobilization and demobilization shall cover all preparatory work, obtaining all permits, insurance and bonds, movement of personnel, equipment, supplies and incidentals to the project site, preconstruction photographs and videos, the establishment of temporary offices, magnetometer survey, and other construction facilities necessary for work on this project. It shall include removal of all personnel, equipment, supplies and incidentals from the project site, removal of temporary offices and other construction facilities necessary for work on this project, all as required for the proper performance and completion of the work. Payment will be made at the contract lump sum price, subject to the following provisions:

Partial payments for mobilization and demobilization will be made in accordance with the following schedule up to a maximum of 10 percent of the total contract amount (including this item), and payment of any remaining amount will be made upon completion of all work under the contract.

<u>Percent of Total Contract Amount Earned</u>	<u>Allowable Percent of the Lump Sum Price for the Item</u>
1 st Partial Estimate	25%
10%	50%
25%	75%
50%	100%

No price adjustments will be made for this item due to changes in the work.

4.11 #57 STONE (ITEM 11)

- A. Measurement: #57 Stone shall be measured by the ton (2,000 pounds). Quantities will be computed to the nearest tenth of a ton. If rip-rap is delivered by truck, measurement will be based on certified weight tickets furnished to the ENGINEER by the CONTRACTOR. If stone is delivered by barge, measurement will be made by calculation from barge displacement in a manner acceptable to the ENGINEER, based on water 62.4 pounds per cubic foot.
- B. Payment: #57 Stone will be paid for at the contract unit prices for “#57 Stone” per ton. Price and Payment shall include all costs of furnishing, hauling, handling and placing to the lines and grades as shown on the plans.

4.12 RIP RAP R650 & R1500 (ITEMS 12 & 13)

- A. Measurement: Rip-rap shall be measured by the ton (2,000 pounds). Quantities will be computed to the nearest tenth of a ton. If rip-rap is delivered by truck, measurement will be based on certified weight tickets furnished to the ENGINEER by the CONTRACTOR.

If rip-rap is delivered by barge, measurement will be made by calculation from barge displacement in a manner acceptable to the ENGINEER, based on water 62.4 pounds per cubic foot.

- B. Payment: Rip-rap will be paid for at the contract unit prices per ton. Price and Payment shall include all costs of furnishing, hauling, handling and placing to the lines and grades as shown on the plans.

4.13 MARINE HAZARD MARKERS (ITEM 14)

- A. Measurement: Hazard Markers will be measured on a per “each” basis installed as shown on the drawings. The Contractor shall measure all poles prior to driving, and shall note all cut-off lengths, so as to determine the lengths actually driven in the field. The net lengths of poles that are installed for marine hazard markers shall be noted for “AS-BUILT” records, only.
- B. Payment: Marine Hazard Markers shall be paid for at the contract unit price per each, which price and payment shall be full compensation for furnishing all signs, lanterns, labor, material, timber poles, equipment and all other incidentals as specified herein and as shown on the drawings.

4.14 ALTERNATE 2 MOBILIZATION (ITEM 15)

- A. Measurement: Measurement for payment for mobilization and demobilization will be on a lump-sum basis as specified herein.
- B. Payment: Payment for mobilization and demobilization shall cover all preparatory work, obtaining all permits, insurance and bonds, movement of personnel, equipment, supplies and incidentals to the project site, preconstruction photographs and videos, the establishment of temporary offices, magnetometer survey, and other construction facilities necessary for work on this project. It shall include removal of all personnel, equipment, supplies and incidentals from the project site, removal of temporary offices and other construction facilities necessary for work on this project, all as required for the proper performance and completion of the work. Payment will be made at the contract lump sum price, subject to the following provisions:

Partial payments for mobilization and demobilization will be made in accordance with the following schedule up to a maximum of 10 percent of the total contract amount (including this item), and payment of any remaining amount will be made upon completion of all work under the contract.

<u>Percent of Total Contract Amount Earned</u>	<u>Allowable Percent of the Lump Sum Price for the Item</u>
1 st Partial Estimate	25%
10%	50%
25%	75%
50%	100%

No price adjustments will be made for this item due to changes in the work.

4.15 WOODEN PIER WITH COMPOSITE DECK (ITEM 16)

- A. Measurement: Measurement for Wooden Pier with Composite Deck shall be made on a per linear foot basis installed as shown on the plans.
- B. Payment: Payment shall be made on a per linear foot basis, and shall include the cost of furnishing and installing treated timber structural components, handrail components, and composite decking components, including all hardware.

4.16 PIER LANDING STAIRS WITH CONCRETE PAD (ITEM 17)

- A. Measurement: Measurement for Pier Landing Stairs with Concrete Pad shall be made on a lump sum basis for constructing the landing stairs and concrete pad as shown on the drawings.
- B. Payment: Payment shall be made on a lump sum basis, and shall include the cost of furnishing and installing treated timber structural components, handrail components, and composite decking components, including all hardware; payment shall also include all labor, materials, concrete, structural steel, and formwork for construction of the concrete pad.

4.17 WOODEN PILE (ITEM 18)

- A. Measurement and payment for timber piles will be per each timber pile installed under Item 18 – WOODEN PILE.

END OF SECTION

SECTION 01050

FIELD ENGINEERING AND SURVEYING

PART 1 - GENERAL

1.01 REQUIREMENTS INCLUDED

Contractor shall provide and pay for field engineering and field surveying services including topographic and bathymetric surveys required for the project.

- 1) Survey work required in execution of the project.
- 2) Civil, structural or other professional engineering services specified, or required to execute the Contractor's construction methods.

1.02 RELATED REQUIREMENTS

- A. Conditions of the Contract.
- B. Section 01010: Summary of Work.

1.03 QUALIFICATIONS OF SURVEYOR OR ENGINEER

Registered professional engineer of the discipline or registered land surveyor required for the specific service on the project, licensed in the State of Louisiana, acceptable to the owner.

1.04 SURVEY REFERENCE POINTS

- A. Existing basic horizontal and vertical control points for the project are those designated on the drawings.
- B. Locate and protect control points prior to starting work, and preserve all permanent reference points during construction.
 - 1) Make no changes or relocations without prior written notice to the Engineer.
 - 2) Report to the Engineer when any reference point is lost or destroyed, or requires relocation because of necessary changes in grades or locations.
 - 3) Require surveyor to replace project control points which may be lost or destroyed.
 - a) Establish replacements based on original survey control.

1.05 PROJECT SURVEY REQUIREMENTS

- A. Establish temporary bench marks as needed, referenced to data established by survey control points. Record locations, with horizontal and vertical data, on Project Record Documents.
- B. Establish lines and levels, locate and lay out, by instrumentation and similar appropriate means.
- C. From time to time, verify layouts by same methods, as directed by the Engineer.

1.06 RECORDS

Maintain a complete, accurate log of all control and survey work as it progresses.

PART 2 - PRODUCTS (NOT USED)

PART 3 - EXECUTION (NOT USED)

END OF SECTION

SECTION 01152

REQUESTS FOR PAYMENT

PART I - GENERAL

1.01 REQUIREMENTS INCLUDED

Submit applications for payment to the Engineer in accord with the schedule established by Conditions of the Contract.

1.02 RELATED WORK SPECIFIED ELSEWHERE

- A. Agreement between owner and Contractor: Unit Price.
- B. Conditions of the Contract: Progress Payments, Retainages and Final Payment.
- C. Section 01380: Construction Photographs and Video Taping.
- D. Section 01700: Contract Closeout.

1.03 FORMAT AND DATA REQUIRED

- A. Submit payment requests in the form required by owner with itemized data typed on 8 ½ x 11 white paper continuation sheets.
- B. Provide itemized data on continuation sheet: format, schedules, line items and values.

1.04 SUBSTANTIATING DATA FOR PROGRESS PAYMENTS

- A. All payment requests must be accompanied by a completed pay request checklist and must include a signed affidavit regarding previous payments received, a short progress narrative describing work performed since previous payment submittal, progress photos as per Section 01380, current project schedule and invoices for any stored materials billed. The pay request checklist form shall be as provided on page 01152-3. All items required on the checklist must be included with each pay request for the request to be considered.
- B. When the Owner or the Engineer requires additional substantiating data, the Contractor shall submit suitable information, with a cover letter.
- C. Submit one copy of all data required with a cover letter for each monthly pay request. Any additional substantiating data requested shall also be submitted as required in Part B above.

1.05 PREPARATION OF APPLICATION FOR FINAL PAYMENT

- A. Fill in application form as specified for progress payments.
- B. Use continuation sheet for presenting the final statement of accounting as specified in section 01700 - Contract Closeout.

1.06 SUBMITTAL PROCEDURE

- A. Submit applications for payment to the Engineer at the times stipulated in the Agreement.
- B. Number: Two hard copies or one electronic copy of each application.
- C. When the Engineer finds application properly completed and correct, he will transmit certificate for payment to the owner, with copy to Contractor.

PART 2 - PRODUCTS (NOT USED)

PART 3 - EXECUTION (NOT USED)

PAY REQUEST CHECKLIST
(CONSTRUCTION CONTRACT)

PARTIAL PAY REQUEST:

- Construction Schedule (Updated as needed) _____
- Progress Narrative _____
- Schedule of Values _____
- Progress Photos _____
- List of Stored Materials Billed _____
- Invoice for Stored Materials Billed _____
- Insurance for (off Site) _____
- Stored Materials Billed _____

FINAL PAY REQUEST:

- Application for Payment _____
 - w/Final Statement of Accounts _____
- Punch List (checked off) _____
- O & M Manuals (Date Submitted) _____
- Record Drawings (Date Submitted) _____
- Clear L & P Certificate _____
- Warranties & Bonds _____
- Consent of Surety to Final Payment _____
- Letter from Contractor stating that _____
 - he shall warranty the work for
 - one year following date of
 - Substantial Completion _____
- Verification of Bond to Remain in _____
 - effect for one year from Final
 - Payment _____

END OF SECTION

SECTION 01153

CHANGE ORDER PROCEDURES

PART 1 – GENERAL

1.01 REQUIREMENTS INCLUDED

- A. Promptly implement change order procedures.
 - 1. Provide full written data required to evaluate changes.
 - 2. Maintain detailed records of work done on a time-and-material/force account basis.
 - 3. Provide full documentation to Engineer on request.
- B. Designate in writing the member of Contractor's organization.
 - 1. Who is authorized to accept changes in the Work.
 - 2. Who is responsible for informing others in the contractors employ of the authorization of changes in the Work.
- C. Owner will designate in writing the person who is authorized to execute Change Orders.

1.02 DEFINITIONS

- A. Change order: See General Conditions.

1.03 PRELIMINARY PROCEDURES

- A. Owner or Engineer may initiate changes by submitting a Proposal Request to Contractor. Request will include:
 - 1. Detailed description of the Change, Products, and location of the change in the Project.
 - 2. Supplementary or revised Drawings and Specifications.
 - 3. The projected time span for making the change, and a specific statement as to whether overtime work is, or is not, authorized.
 - 4. A specific period of time during which the requested price will be considered valid.
 - 5. Such request is for information only, and is not an instruction to execute the changes, nor to stop work in progress.
- B. Contractor may initiate changes by submitting a written notice to Engineer, containing:

1. Description of the proposed changes.
2. Statement of the reason for making the changes.
3. Statement of the effect on the Contract Sum and the Contract Time.
4. Statement of the effect on the work of separate contractors.
5. Documentation supporting any change in Contract Sum or Contract Time, as appropriate.

1.04 DOCUMENTATION OF PROPOSALS AND CLAIMS

- A. Support each quotation for a lump-sum proposal, and for each unit price which has not previously been established, with sufficient substantiating data to allow Engineer to evaluate the quotation.
- B. On request, provide additional data to support time and cost computations:
 1. Labor required.
 2. Equipment required.
 3. Products required.
 - a. Recommended source of purchase and unit cost.
 - b. Quantities required.
 4. Taxes, insurance and bonds.
 5. Credit for work deleted from Contract, similarly documented.
 6. Overhead and profit.
 7. Justification for any change in Contract Time.
- C. Support each claim for additional costs, and for work done on a time-and-material/force account basis, with documentation as required for a lump-sum proposal, plus additional information.
 1. Name of the Owner's authorized agent who ordered the work, and date of the order.
 2. Dates and times work was performed, and by whom.
 3. Time record, summary of hours worked, and hourly rates paid.
 4. Receipts and invoices for:
 - a. Equipment used, listing dates and times of use.
 - b. Products used, listing of quantities.
 - c. Subcontracts.

1.05 PREPARATION OF CHANGE ORDERS

- A. Engineer will prepare each Change Order.
- B. Form: Owner's Form, to be provided to the Contractor.
- C. Change Order will describe changes in the Work, both additions and deletions, with attachments of revised Contract Documents to define details of the change.

- D. Change Order will provide an accounting of the adjustment in the Contract Sum and in the Contract Time.

1.06 LUMP SUM/FIXED PRICE CHANGE ORDER

- A. Content of Change Orders will be based on, either:
 - 1. Engineer's Proposal Request and contractor's responsive Proposal as mutually agreed between Owner and Contractor.
 - 2. Contractor's Proposal for a change, as recommended by Engineer.
- B. Owner and Engineer will sign and date the Change Order as authorization for the Contractor to proceed with the changes.
- C. Contractor may sign and date the Change Order to indicate agreement with the terms therein.

1.07 UNIT PRICE CHANGE ORDER

- A. Content of Change Orders will be based on, either:
 - 1. Engineer's definition of the scope of the required changes.
 - 2. Contractor's Proposal for a change, as recommended by Engineers.
 - 3. Survey of completed work.
- B. The amounts of the unit prices to be:
 - 1. Those stated in the Agreement.
 - 2. Those mutually agreed upon between Owner and Contractor.
- C. When quantities of each of the items affected by the Change Order can be determined prior to start of the work:
 - 1. Owner and Engineer will sign and date the Change Order as authorization for Contractor to proceed with the changes.
 - 2. Contractor may sign and date the Change Order to indicate agreement with the terms therein.
- D. When quantities of the items cannot be determined prior to start of the work:
 - 1. Engineer or Owner will issue a construction change authorization directing Contractor to proceed with the change on the basis of unit prices, and will cite the applicable unit prices.
 - 2. At completion of the change, Engineer will determine the cost of such work

based on the unit prices and quantities used.

- a. Contractor shall submit documentation to establish the number of units of each item and any claims for a change in Contract Time.
3. Engineer will sign and date the Change Order to establish the change in Contract Sum and in Contract Time.
4. Owner and contractor will sign and date the change Order to indicate their agreement with the terms therein.

1.08 CORRELATION WITH CONTRACTOR'S SUBMITTALS

- A. Periodically revise Schedule of Values and Application for Payment forms to record each change as a separate item of work, and to record the adjusted Contract Sum.
- B. Periodically revise the Construction Schedule to reflect each change in Contract Time.
 1. Revise subschedules to show changes for other items of work affected by the changes.
- C. Upon completion of work under a Change Order, enter pertinent changes in Record Documents.

PART 2 – PRODUCTS

Not Used.

PART 3 – EXECUTION

Not Used.

END OF SECTION

SECTION 01200

PROJECT MEETINGS

PART I - GENERAL

1.01 REQUIREMENTS INCLUDED

- A. Engineer shall schedule and administer pre-construction meeting, periodic progress meetings, and specially called meetings throughout progress of the work. At a minimum, he shall perform the following duties:
- 1) Prepare agenda for meetings.
 - 2) Distribute written notice of each meeting four days in advance of meeting date.
 - 3) Make physical arrangements for meetings.
 - 4) Preside at meetings.
 - 5) Record the minutes; include significant proceedings and decisions.
 - 6) Reproduce and distribute copies of minutes within three days after each meeting.
 - (a) To participants in the meeting
 - (b) To parties affected by decisions made at the meeting
- B. Representative of contractors, subcontractors and suppliers attending meetings shall be qualified and authorized to act on behalf of the entity each represents.

1.02 RELATED REQUIREMENTS

- A. Instructions to Bidders: Pre-bid Conferences.
- B. Section 01340: Shop Drawings, Product Data and Samples.

1.03 PRE-CONSTRUCTION MEETING

- A. Schedule prior to issuance of Notice to Proceed.
- B. Location: A central site, convenient for all parties, designated by the Engineer.
- C. Attendance:
- 1) Owner's Representative.
 - 2) Engineer and his professional consultants.

- 3) Contractor's Superintendent.
- 4) Major Subcontractors.
- 5) Major suppliers.
- 6) Others as appropriate.

D. Suggested Agenda:

- 1) Distribution and discussion of:
 - (a) List of major subcontractors and suppliers.
 - (b) Projected Construction Schedules.
 - (c) Values for progress payment purposes.
- 2) Critical work sequencing.
- 3) Major equipment deliveries and priorities.
- 4) Project Coordination:
 - (a) Designation of responsible personnel.
- 5) Procedures and processing of:
 - (a) Field decisions.
 - (b) Proposal requests.
 - (c) Submittals.
 - (d) Change Orders.
 - (e) Applications for Payment.
- 6) Adequacy of distribution of Contract Documents.
- 7) Procedures for maintaining Record Documents.
- 8) Use of premises:
 - (a) Work and storage areas.
 - (b) Owner's requirements.
- 9) Construction facilities, controls and construction aids.
- 10) Temporary utilities.
- 11) Safety and first-aid procedures.

- 12) Security procedures.
- 13) Housekeeping procedures.

1.04 PROGRESS MEETINGS

- A. Schedule regular monthly meetings.
- B. Hold called meetings to review progress of the work.
- C. Location of the meetings: As designated by the Engineer.
- D. Attendance:
 - 1) Engineer, and his professional consultants, as needed.
 - 2) Contractor.
 - 3) Subcontractors, as appropriate to the agenda.
 - 4) Suppliers, as appropriate to the agenda.
 - 5) Others.
- E. Suggested Agenda:
 - 1) Review, approval of minutes of previous meeting.
 - 2) Review of work progress since previous meeting.
 - 3) Field observations, problems, conflicts.
 - 4) Problems which impede Construction Schedule.
 - 5) Review of off-site fabrication, delivery schedules.
 - 6) Corrective measures and procedures to regain projected schedule.
 - 7) Revisions to Construction Schedule.
 - 8) Progress, schedule, during succeeding work period.
 - 9) Coordination of schedules.
 - 10) Review submittal schedules; expedite as required.
 - 11) Maintenance of quality standards.
 - 12) Pending changes and substitutions.

13) Review proposed changes for:

- (a) Effect on Construction Schedule and on completion date.
- (b) Effect on other contracts of the project.

14) Other business.

PART 2 - PRODUCTS (NOT USED)

PART 3 - EXECUTION (NOT USED)

END OF SECTION

SECTION 01310

CONSTRUCTION SCHEDULING

PART 1 – GENERAL

1.01 PROGRAM DESCRIPTION

- A. A Critical Path Method (CPM) construction schedule shall be used to control the work of this Contract and to provide a definitive basis for determining job progress. The construction schedule shall be prepared, maintained, and updated by the Contractor. The construction schedule shall be reviewed by the Engineer as described herein. All work shall be done in accordance with the established CPM schedule and the Contractor and his/her subcontractors shall be responsible for cooperating fully with the Engineer and the Owner in effectively utilizing the CPM schedule.
- B. The CPM schedule to be prepared and submitted by the Contractor shall consist of a CPM network (diagram of activities) in the Time Scale Logic and a computer-generated schedule (print-out) as specified herein.
- C. Within ten calendar days following written Notice to Proceed, the Contractor shall submit to the Engineer for review and approval a Preliminary Guideline CPM Schedule covering the first 60 calendar days of Work to be performed.
- D. The Preliminary Guideline CPM Schedule shall:
 - 1. Illustrate a feasible CPM schedule for completion of the work under this Contract within the time specified.
 - 2. Provide an elementary example of a CPM schedule in the format to be used for the detailed CPM schedule specified. The Preliminary Guideline CPM Schedule is not as detailed as the CPM schedule required under this Contract.
 - 3. Establish mandatory milestone dates. Designate milestones on the Preliminary Guideline CPM Schedule with asterisks.
- E. The Preliminary Guideline CPM Schedule is not to be considered binding except for the time required for contract completion and the mandatory milestones.
- F. Contractor shall develop his own outline of the Work and prepare his proposed CPM schedule. The computer-based schedule shall be the product of a recognized commercial computer software producer and shall meet all of the requirements defined herein.

1.02 QUALIFICATIONS

- A. Have the capability of preparing and utilizing the specified CPM scheduling technique. A statement of CPM capability shall be submitted in writing to the Engineer within ten calendar days after the award of the Contract and will verify that either the Contractor's organization has in-house capability qualified to use the technique or that the Contractor employs a consultant who is so qualified. Capability shall be verified by description of the construction projects to which the Contractor or his/her consultant has successfully applied the CPM scheduling technique and which were controlled throughout the duration of the project by means of systematic use and updating of a computer-based CPM schedule. The submittal shall include the name of the individual on the Contractor's staff who will be responsible for the CPM schedule and for providing the required updating information.

1.03 NETWORK REQUIREMENTS

- A. The network shall show the order and inter-dependence of activities and the sequence in which the work is to be accomplished as planned by the Contractor. The basic concept of a network analysis diagram shall be followed to show how the start of a given activity is dependent on the completion of preceding activities and its completion restricts the start of following activities.
- B. Detailed network activities shall include: construction activities, the submittal and approval of samples of materials and shop drawings, the procurement of materials and equipment, fabrication of materials and equipment and their delivery, installation and testing, start-up and training. Break the work into activities with duration no longer than 20 working days each, except as to non-construction activities (such as procurement of materials and delivery of equipment) and any other activities for which the Engineer may approve the showing of longer duration. To the extent feasible, activities related to a specific physical area of the work shall be grouped on the network for ease of understanding and simplification.
- C. Separate activities shall be provided for each significant identifiable function in each trade area in each facility. Activities shall be so identified that there will be no reasonable doubt as to how much work remains on each. Specific activities which shall be included are: all sub contract work, all interface work between subcontractors and between the Contractor and subcontractors leakage tests of tanks and pipelines, electrical connections to each item of equipment, supplier and manufacturer technical assistance, mechanical connections to each item of equipment all tests concrete finishing, each item of site work, (including restraints on other activities) and all utilities, fuels and chemicals.
- D. Each activity on the network shall have the following indicated on the node

representing it.

1. A single duration (i.e., the single best estimate of elapsed time considering the scope of the work involved in the activity and the resources planned for accomplishing the activity) expressed in working days.
 2. A five character (or less) code indicative of the party responsible for accomplishing the activity.
 3. A cost estimate for each activity which, when accumulated with the cost of all activities, equals the total contract cost. Estimated overhead and profit shall be prorated throughout all activities. Materials costs shall be assigned to delivery activities.
 4. A brief description of the activity.
 5. Manpower estimate for each activity.
- E. The selection and number of activities shall be subject to the Engineer's approval. The detailed network shall be time scaled. In addition to the brief description, submit a separate list of all activities containing a detailed narrative of the scope of each activity, including the trades and subcontractors involved, the activity duration, and the cost of each activity as it pertains to the pay items on the Schedule of Values.
- F. To the extent that the network or any revision thereof shows anything not jointly agreed upon or fails to show anything jointly agreed upon, it shall not be deemed to have been approved by the Engineer. Failure to include on a network any element of work required for the performance of this Contract shall not excuse the Contractor from completing all work required within any applicable completion date, notwithstanding the review of the network by the Engineer.
- G. Except where earlier completions are specified, CPM schedules which show completion of all work prior to the contractor completion date may be approved by the Engineer but in no event shall they be acceptable as a basis for claim for delay against the Owner or Engineer by the Contractor.

1.04 COMPUTER-GENERATED SCHEDULE REQUIREMENTS

- A. Each computer-generated schedule submittal from the CPM activity network shall include the following tabulations: a list of activities in numerical order, a list of activity precedence's, a schedule sequenced by Early Start Date and a schedule sequenced by Total Float. Each schedule shall include the following minimum items:
1. Activity numbers

2. Estimated duration
3. Activity description
4. Early start date (calendar dated)
5. Early finish date (calendar dated)
6. Latest allowable start date (calendar dated)
7. Latest allowable finish date (calendar dated)
8. Status (whether critical)
9. Estimated cost of the activity
10. Total float and free float

B. In addition, each schedule shall be prefaced with the following summary data:

1. Contract name and number
2. Contractor's name
3. Contract duration
4. Contract schedule
5. The effective or starting date of the schedule (the date indicated in the Notice to Proceed).

C. The work day to calendar date correlation shall be based on an 8-hour day and 40-hour week with adequate allowance for holidays, adverse weather and all other special requirements of the work.

1.05 INITIAL CONFERENCE

A. Within ten days following the receipt of the Notice to Proceed, meet with the Engineer to discuss and agree on the proposed standards for the CPM schedule. At this conference submit to the Engineer a preliminary network defining the planned operations during the first 60 calendar days after Notice to Proceed. The general approach for the balance of the project shall be indicated. Cost of activities expected to be completed or partially completed before submission and approval of the complete network shall be included.

1.06 APPROVED CPM SCHEDULE

- A. Within 45 days following the receipt of the Notice to Proceed, submit two prints of the proposed CPM activity network and a computer-generated schedule to the Engineer. Following review by the Engineer and Owner, the Contractor shall incorporate the Engineer's comments into the network and submit five prints and two reproducible of the revised network and two copies of the computer-generated schedule. This final submittal shall be delivered to the Engineer within 60 days after the Notice to Proceed.
- B. CPM schedules which contain activities showing negative float or which extend beyond the contract completion date in the computer-generated schedule will not be approved.
- C. The Contractor shall participate in the initial review and evaluation of the proposed network diagram and schedule by the Engineer. The approved network shall then be approved CPM schedule to be used for planning, organizing and directing the work, and reporting progress.
- D. Approval of the CPM activity network by the Engineer is advisory only and shall not relieve the Contractor of responsibility for accomplishing the work within the contract completion date. Omissions and errors in the approved CPM schedule shall not excuse performance less than that required by the Contract Approval by the Engineer in no way makes the Engineer an insurer of the CPM schedule's success or liable for time or cost overruns flowing from its shortcomings. The Owner hereby disclaims any obligation or liability by reason of approval by its agent, the Engineer, of the CPM schedule.
- E. The CPM activity network shall be prepared in accordance with the format used in the Preliminary Guideline CPM Schedule noted above. The network shall be submitted on sheets 24-in by 36-in and may be divided into as many separate sheets as required.

1.07 PROGRESS REPORTING

- A. Progress under the approved CPM schedule shall be evaluated monthly by the Contractor and the Engineer. Not less than seven days prior to each monthly progress meeting, they shall meet at the job-site and jointly evaluate the status of each activity on which work has started or is due to start, based on the preceding CPM schedule; to show actual progress, to identify those activities started and those completed during the previous period, to show the estimated time required to complete or the percent complete of each activity started but not yet completed and to reflect any changes indicated for the network. Activities shall not be considered to be complete until they are, in fact, 100 percent complete.
- B. At each progress meeting, submit a narrative report based on the CPM schedule evaluation described above, in a format agreed upon by the Contractor

and the Engineer. The report shall include a description of the progress during the previous period in terms of completed activities, and explanation of each activity which is showing a delay, a description of problem areas, current and anticipated delaying factors and their estimated impact on performance of other activities and completion dates and an explanation of corrective action taken or proposed. This report, as well as the CPM Status Report, will be discussed at each progress meeting.

1.08 RESPONSIBILITY FOR SCHEDULE COMPLIANCE

- A. Whenever it becomes apparent from the current CPM schedule and CPM Status Report that delays to the critical path have resulted and the contract completion date will not be met, or when so directed by the Engineer, Contractor shall take some or all of the following actions at no additional cost to the Owner. He shall submit to the Engineer for approval, a written statement of the steps intended to take to remove or arrest the delay to the critical path in the approved schedule.
 - 1. Increase construction manpower in such quantities and crafts as will substantially eliminate the backlog of work.
 - 2. Increase the number of working hours per shift, shifts per day, working days per week, the amount of construction equipment, or any combination of the foregoing, sufficiently to substantially eliminate the backlog of work.
 - 3. Reschedule activities to achieve maximum practical concurrence of accomplishment of activities and comply with the revised schedule.
- B. If when so requested by the Engineer, failure to submit a written statement of the steps intended to take or should fail to take such steps as approved by the Engineer, the Engineer may direct the Contractor to increase the level of effort in man-power (trades), equipment and work schedule (overtime, weekend and holiday work, etc) to be employed by the Contractor in order to remove or arrest the delay to the critical path in the approved schedule and the Contractor shall promptly provide such level of effort at no additional cost to the Owner.

1.09 ADJUSTMENT OF CONTRACT SCHEDULE AND COMPLETION TIME

- A. If the Contractor desires to make changes in his/her method of operating which affect the approved CPM schedule, he/she shall notify the Engineer in writing stating what changes are proposed and the reason for the change. If the Engineer approves these changes, the Contractor shall review and submit for approval, without additional cost to the Owner, all of the affected portions of the CPM network. The CPM schedule shall be adjusted by the Contractor only after prior approval of his/her proposed changes by the Engineer. Adjustments may

consist of changing portions of the activity sequence, activity durations, division of approved activities, or other adjustments as maybe approved by the Engineer. The addition of extraneous, non-working activities and activities which add unapproved restraints to the CPM schedule shall not be approved.

- B. If the completion of any activity, whether or not critical, falls more than 100 percent behind its approved duration, submit for approval a schedule adjustment showing each such activity divided into two activities reflection completed versus uncompleted work.
- C. Shop drawings which are not approved on the first submittal or within the schedule time and equipment which do not pass the specified tests shall be immediately rescheduled.
- D. The contract completion time will be adjusted only for causes specified in this Contract. In the event the Contractor requests an extension of any contract completion date, he/she shall furnish such justification and supporting evidence as the Engineer may deem necessary to determine whether the Contractor is entitled to an extension of time under the provisions of this Contract. The Engineer will after receipt of such justification and supporting evidence, make findings offset and will advise the Contractor in writing thereof. If the Engineer finds that the Contractor is entitled to any extension of any contract completion date, the Engineer's determination as to the total number of days extension shall be based upon the currently approved CPM schedule and on all data relevant to the extension. Such data shall be included in the next updating of the schedule. Actual delays in activities which, according to the CPM schedule, do not affect any contract completion date shown by the critical path in the network will not be the basis for a change therein.
- E. Each request for change in any contract completion date shall be submitted by the Contractor to the Engineer within 30 days after the beginning of the delay for which a time extension is requested but before the date of final payment under this Contract. No time extension will be granted for requests which are not submitted within the foregoing time limit.
 - 1. From time to time it may be necessary for the contract schedule or completion time to be adjusted by the Owner to reflect the effects of job conditions, weather, technical difficulties, strikes, unavoidable delays on the part of the Owner or its representatives and other unforeseeable conditions which may indicate schedule adjustments or completion time extensions. Under such conditions, the Engineer will direct the Contractor to reschedule the work or contract completion time to reflect the changed conditions and the Contractor shall revise his/her schedule accordingly. No additional compensation will be made to the Contractor for such schedule changes except for unavoidable overall contract time extensions beyond the actual completion of all unaffected work, in which case the

Contractor shall take all possible action to minimize any time extension and any additional cost to the Owner. Available float time in the CPM schedule may be used by the Owner as defined by the Engineer, as well as by the Contractor.

- F. The Owner controls the float time in the approved CPM network and, therefore, without obligation to extend either the overall completion date or any intermediate completion dates set out in the CPM network, the Owner may initiate changes to the work that absorb float time only. Owner initiated changes that affect the critical path on the approved CPM network shall be the sole grounds for extending (or contracting) said completion dates. Contractor-initiated changes that encroach on the float time identified in the approved CPM network may be accomplished with the Owner's concurrence. Such changes, however, shall give way to Owner-initiated changes competing for the same float time.

PART 2 - PRODUCTS

Not Used.

PART 3 - EXECUTION

Not Used.

END OF SECTION

SECTION 01340

SHOP DRAWINGS, PRODUCT DATA, AND SAMPLES

PART 1 - GENERAL

1.01 REQUIREMENTS INCLUDED

Submit shop drawings, product data and samples required by Contract Documents.

1.02 RELATED REQUIREMENTS

- A. Conditions of the Contract: Definitions and Additional responsibilities of parties.
- B. Designate in a separate schedule, the dates for submission and the dates that reviewed shop drawings, product data and samples will be needed.

1.03 SHOP DRAWINGS

- A. Drawings shall be presented in a clear and thorough manner.
 - 1) Details shall be identified by reference to sheet and detail as shown on contract drawings.
- B. Minimum sheet size: 8 1/2 inches by 11 inches.

1.04 PRODUCT DATA

- A. Preparation
 - 1) Clearly mark each copy to identify pertinent products or models.
 - 2) Show performance characteristics and capacities.
 - 3) Show dimensions.
- B. Manufacturer's standard schematic drawings and diagrams.
 - 1) Modify drawings and diagrams to delete information which is not applicable to the work.
 - 2) Supplement standard information to provide information specifically applicable to the work.

1.05 SAMPLES

- A. Office samples shall be of sufficient size and quantity to clearly illustrate:

- 1) Functional characteristics of the product, with integrally related parts and attachment devices.
- 2) Full range of color, texture and pattern.

1.06 CONTRACTOR RESPONSIBILITIES

- A. Review shop drawings, product data and samples prior to submission.
- B. Determine and verify:
 - 1) Field measurements
 - 2) Field construction criteria
 - 3) Catalog numbers and similar data
 - 4) Conformance with specifications
 - 5) Confirm compatibility of equipment to be supplied within location to be erected.
- C. Coordinate each submittal with requirements of the work and of the contract documents.
- D. Notify the Engineer in writing, at time of submission, of any deviations in the submittals from requirements of the contract documents.
- E. Begin no fabrication or work which requires submittals until return of submittals with Engineer approval.

1.07 SUBMISSION REQUIREMENTS

- A. Make submittals promptly in accordance with approved schedule, and in such sequence as to cause no delay in the work or in the work of any other contractor.
- B. Number of Submittals required:
 - 1) Shop Drawings and Product Data: Submit one (1) set of reproducibles and two (2) sets of prints of each shop drawing submittal for review. After final review in which there are no exceptions noted or referenced the contractor shall furnish the Engineer two (2) complete sets and one (1) electronic set for use by the Engineer and Owner.
 - 2) Samples: Submit the number stated in each specification section.
- C. Submittals shall contain:
 - 1) The date of submission and the dates of any previous submissions.
 - 2) The project title and number.

- 3) Contract identification.
- 4) The names of:
 - (a) Contractor
 - (b) Supplier
 - (c) Manufacturer
- 5) Identification of the product, with the specification section number.
- 6) Field dimensions, clearly identified as such.
- 7) Relation to adjacent or critical features of the work or materials.
- 8) Applicable standards, such as ASTM or Federal specification numbers.
- 9) Identification of deviations from Contract Documents.
- 10) Identification of revisions on resubmittals.
- 11) A blank space for Contractor and Engineer stamps.
- 12) Contractor's stamp, initialed or signed, certifying to review of submittal, verification of products, field measurements and field construction criteria, and coordination of the information within the submittal with requirements of the work and of Contract Documents.

D. Submittals should be made using the Letter of Transmittal form attached to this section as page 01340-6. Submittals received without this submittal form will be returned to the Contractor without action. Transmittals shall be numbered in sequence for each Section of the Specifications. The number after the dash indicates the Section of the Specifications, and the number before the dash is the sequence number of the transmittal (1-15100 would be the first transmittal applicable to Section 15100 of the Specifications. 2-15100 would be the second transmittal for Section 15100, etc.)

1.08 RESUBMISSION REQUIREMENTS

- A. Make any corrections or changes in the submittals required by the Engineer and resubmit until no exceptions are taken by the Engineer.
- B. Shop Drawings and Product Data:
 - 1) Revise initial drawings or data, and resubmit as specified for the initial submittal.

- 2) Indicate any changes which have been made other than those requested by the Engineer.

C. Samples: Submit new samples as required for initial submittal.

1.09 DISTRIBUTION

A. Distribute reproductions of Shop Drawings and copies of Product Data which carry the Engineer review stamp to:

- 1) Job site file
- 2) Record Documents file
- 3) Other affected contractors
- 4) Subcontractors
- 5) Supplier or Fabricator

B. Distribute samples which carry the Engineer review stamp as directed by the Engineer.

1.10 ENGINEER DUTIES

A. Review submittals within 15 calendar days.

B. Affix review stamp and initials or signature, and indicate requirements, if any, for resubmittal.

C. Return submittals to Contractor.

1.11 ENGINEER'S ACTION

A. Final unrestricted release. Work may proceed, provided it complies with contract documents, when submittal is returned with the following:

Marking: No exceptions taken

B. Final-But-Restricted Release. Work may proceed, provided it complies with notations and corrections on submittal and with contract documents, when submittal is returned with the following:

Marking: Revised as Noted.

C. Returned for Resubmittal. Do not proceed with work. Revise submittal in accordance with notations thereon, and resubmit without delay to obtain a different action marking. Do not allow submittals with the following marking (or unmarked submittals where a marking is required) to be used in connection with performance of the work:

Marking: Amend and Resubmit or

Rejected - See Remarks

PART 2 - PRODUCTS (NOT USED)

PART 3 - EXECUTION (NOT USED)

END OF SECTION

LETTER OF TRANSMITTAL

Transmittal of Shop Drawings, Monolith Drawings, Equipment Data, Material Sample or Manufacturer's Certificates of Compliance for Approval.						<input type="checkbox"/> New Transmittal <input type="checkbox"/> Re-Submittal	
Project: TCHEFUNCTE HABITAT RESTORATION							
TO: DIGITAL ENGINEERING AND IMAGING INC 527 W. Esplanade Ave. Ste. 200 Kenner, LA 70065						From:	
						Transmittal No.	
						(If Any) Previous Transmittal No.	
Item No.	Description of Item Submitted, i.e., Type, Size, Model No., Etc.'	Mfg. or Supplier	Mfg. or Contr. Cat., Curve, Drawing or Brochure No.	No. of Copies	Project Specification Section Number	Engineer's Use Only	
						Action Code	
Signature of Contractor: _____ Date: _____							
(THIS SECTION TO BE USED ONLY BY THE ENGINEER TO DESIGNATE ACTION)							
Action Codes. The following codes are given to the items submitted: A - No exceptions taken; B - Revise as noted; C - Amend and resubmit; D - Rejected. See remarks. Corrections and comments made on the shop drawings during this review do not relieve the contractor from compliance with requirements of the drawings and specifications.							
Enclosure Returned (List by Item No.)							
						By: _____ DIGITAL ENGINEERING & IMAGING INC.	
						Date: _____	
Distribution Requested: Contractor _____ Engineer _____ Owner _____							

SECTION 01350

VIBRATION MONITORING

PART 1 – GENERAL

1.01 SUMMARY

- A. This section shall include supplying materials, services, and labor necessary to provide vibration monitoring as required.
- B. The Tchefuncte River Lighthouse is a national historic structure and subject to the requirements of Section 106 of the National Historic Preservation Act (NHPA), as amended (54 U.S.C. § 300101 et seq.), requires federal agencies to “take into account” the effects of their undertakings on historic properties and afford the Advisory Council on Historic Preservation (ACHP) a reasonable opportunity to comment on such undertakings.
- C. The applicant, St. Tammany Parish Government, has procured Permit MVN-2016-00731-EPP, issued by U.S. Army Corps of Engineers, in regards to vibration monitoring. The permit is incorporated into the specifications. The Contractor must meet all requirements of the permit.

1.02 RELATED WORK

- A. Section 06200 – Driven Piles
- B. Section 06500 – Sheet Piles
- C. Section 02270 – Rip Rap

1.03 REFERENCES

- A. National Historic Preservation Act (NCHRP), Section 106
- B. NCHRP 25-25 – Guidelines for Vibration Monitoring
- C. Jefferson Parish Special Provisions
- D. DOTD 2016 Standard Specifications for Roads and Bridges

1.04 SUBMITTALS

- A. Prior to beginning vibration monitoring operations, the Contractor shall submit, in writing to the Engineer, his Vibration Monitoring Plan to comply with the requirements of this section.
 - 1) The submitted plan shall be designed and stamped by a Louisiana Registered Civil or Structural Engineer.
 - 2) The submittal shall also include but is not limited to information on all vibration monitoring devices being used (accelerometers, seismometers, and/or inclinometers), including manufacturer’s specifications and documentation of all components.

- 3) No vibrative work shall be allowed to commence until the Contractor has fulfilled this requirement and received written approval to proceed from the Engineer.
 - 4) Documentation of the condition of the historic structure prior to commencement of adjacent work, including a detailed photo survey of existing damage.
 - 5) Regular condition surveys and reviews during construction to identify damage to evaluate the efficacy of protective measures already in place, and to identify and implement additional corrective steps.
 - 6) Comprehensive report for each structure and feature monitored. Include in each report a discussion of the following:
 - (a) Site conditions and descriptions, including a site map drawn to scale showing the location of the structures and/or sensitive features and the location of the construction activity.
 - (b) Field procedures and equipment used, including seismograph manufacturer, model, and unit serial number.
 - (c) Location where seismograph equipment will be located.
 - (d) The name of the seismograph operator.
 - (e) A digital and a hard copy of all ground vibration time histories, in units of velocity.
 - (f) A record summary of the maximum value of ground vibration in any of the three directions measured (longitudinal, transverse, or vertical), the frequency associated with the maximum value in hertz, and the measured distance between the seismograph and the construction activity.
 - (g) Construction activities including construction equipment used, environmental conditions such as temperature and relative humidity ranges during construction, and other activities that are not construction related (such as flooding).
 - (h) Analysis of results with conclusions and recommendations.
 - (i) Any additional inclusions to the report(s) requested by the Project Engineer.
- B. Acceptance of the work will be contingent on acceptance of the Vibration Monitoring Report.

1.05 PERFORMANCE REQUIREMENTS

- A. Contractor's work must not cause accelerating limits greater than 0.125 in/sec in any direction.
- B. Monitoring Equipment must be capable of measuring and recording vibrations within acceptable limits.
- C. Vibration monitoring system shall include all sensors, data loggers and software for real-time monitoring and data analysis.
- D. See NCHRP 25-25 for other performance requirements.

1.06 MEASUREMENT AND PAYMENT

- A. There will be no separate payment for vibration monitoring. Payment for vibration monitoring services will be the responsibility of the Contractor and shall be included in his cost to perform related work.

PART 2 – PRODUCTS – NOT USED

PART 3 – EXECUTION

3.01 PRE-INSTALLATION

- A. Conduct a pre-installation site inspection with engineer, owner, and stakeholders.
- B. Review and finalize location of vibration monitoring equipment and establishment of no work areas.

3.02 MONITORING

- A. The project engineer shall:
 - 1) Direct the vibration monitoring process. The Contractor is to submit the Vibration Monitoring Plan to the Engineer.
 - 2) Direct the number and placement of monitors to be used for each activity or condition.
- B. Monitoring equipment shall:
 - 1) Directly measure particle velocity (rate of ground movement) in three mutually perpendicular directions (longitudinal, transverse, and vertical) and
 - 2) Be capable of recording vector sum of these three measurements to an accuracy of 0.01 inches per second.

- 3) Be capable of producing a continuous written record of all measurements taken.
- C. A daily report will be furnished to the Engineer including, at a minimum:
- 1) A monitoring location plan,
 - 2) All recorded data, and
 - 3) A narrative of construction activities which is referenced to the recorded data.
- D. The Contractor shall:
- 1) Report to the Engineer's field representative at least twenty-four (24) hours in advance of starting any new construction related activity (or if site conditions change),
 - 2) Request that proper vibration monitoring be provided for this activity and/or condition, and
 - 3) Maintain records of all monitoring data for submission to relevant authorities if required.
- E. Agency staff and consultants who interact with the public and building owners in particular should:
- 1) Be aware of potential human reaction to vibration.
 - 2) Be prepared to explain in terms that can be understood by the average person that just because a person can feel vibration does not automatically mean that damage is occurring.
 - 3) Be prepared to explain that even though older buildings tend to be more susceptible to vibration, adequate measures can be implemented to protect against damage.

3.03 EXCEEDING PERFORMANCE ALLOWANCE

- A. In the occasion that the Performance Requirements in Section 1.06 are exceeded in any direction, the following are to be implemented:
- 1) The laboratory technician shall notify the Contractor and the Owner's field representative immediately.
 - 2) The offending construction activity shall be suspended immediately.
 - 3) Protected structures shall be inspected for additional potential damages.

- 4) The Contractor shall propose to the Engineer corrective measures for the affecting construction activity to ensure that vibration-monitoring limits will not be exceeded.
- 5) Repair of any damage caused by the vibrations above safe limits as specified herein shall be the full responsibility of the Contractor. Repairs made must meet the Secretary of the Interior's Standard for Rehabilitation.

END OF SECTION

SECTION 01380

CONSTRUCTION PHOTOS AND VIDEOS

PART 1 - GENERAL

1.01 REQUIREMENTS INCLUDED

Contractor shall employ a competent photographer to take construction record photographs and video prior to and during the course of the work.

1.02 PHOTOGRAPHY REQUIRED

- A. Video Survey as specified herein (pre-construction).
- B. Provide five (5) photographs each month of each major portion of the work taken at each major stage of construction.
- C. Provide digital files of each photograph identified with contract number, description of view and date.

1.03 COSTS OF PHOTOGRAPHY

Contractor shall pay costs for specified video and photography, and prints. Parties requiring additional photography or prints will pay photographer directly.

PART 2 - PRODUCTS

2.01 Digital Photographs

- A. Color
- B. Identify each with a caption, listing:
 - 1. Name of project.
 - 2. Facility location.
 - 3. Orientation of view.
 - 4. Date and time of exposure.
 - 5. Name of Contractor.

2.02 VIDEOS

- A. Specifications for Audio-Video Survey

Prior to the start of construction of the contract, the Contractor shall furnish to the Engineer the video on USB flash drive of the construction areas. The USB shall be reviewed by the Engineer and either approved or additional coverage will be required to fully show the physical conditions of the work areas. The Contractor shall have the additional coverage videoed and shall not begin work, including

moving equipment and/or material on the project site, until the audio-video survey has been approved by the Engineer. After approval, the Contractor shall supply two copies of the audio-video survey to the Engineer. One copy of the USB will remain available for viewing by the Contractor and may be reviewed by him for any assistance that the USB may provide in resolving disputes which arise with the property owners claiming improper restoration of their properties. That copy of the USB will also be used as a guide by the Engineer, prior to issuance of final payments, in determining the adequacy of restoration and the extent of damages attributable to the Contractor's work. The remaining copy of the USB will be delivered to the Owner.

B. Technical Requirements

The total audio-video recording system and the procedures employed in its use shall be such as to produce a finished product that will fulfill the technical requirements of the project, as well as those more subjective requirements of high-quality audio and video production. The video portion of the recording shall reproduce bright, sharp, clear pictures with accurate colors and shall be free from distortion or any other form of picture imperfection. The audio portion of the recording shall reproduce precise and concise explanatory notes by the camera operator with proper volume, clarity and freedom from distortion.

C. Recorder

The recorder shall be an acceptable digital recording device format.

D. Camera

The color video camera shall have a horizontal resolution of at least 550 lines at center and 4 megapixels.

PART 3 - EXECUTION

3.01 TECHNIQUE FOR STILL PHOTOGRAPHS

- A. Factual presentation.
- B. Correct exposure and focus.
 - 1. High resolution and sharpness.
 - 2. Maximum depth-of-field.
 - 3. Minimum distortion.

3.02 VIEWS REQUIRED FOR STILL PHOTOGRAPHS

- A. Contractor shall photograph from locations to adequately illustrate condition of construction and state of progress. Consult with Engineer at each period of

photography for instructions concerning views required.

- B. Prior to construction, five photographs of pertinent features shall be taken at various locations at the site as selected by the Engineer and promptly submitted to the Engineer. The same views shall be rephotographed during construction showing the installation of all material. Photographs shall also be taken upon completion of the project. Additional progress photographs shall be made monthly throughout the progress of the work at the same locations as above when work has taken place at that location during the month and submitted with each of the Contractor's applications for progress payment.

3.03 TECHNIQUE AND VIEWS REQUIRED FOR VIDEO TAPING

- A. At the start of production, an identification summary shall be read into the record while, at the same time, a wide-angle view with numeric displays shall be provided for a visual record. This summary will include (1) video number, (2) job title, (3) job location, (4) positional location at job start, (5) date and time, (6) weather and (7) any other notable conditions.

- B. Coverage

The recording shall include coverage of all surface features located within the construction zone-of-influence. This zone shall be defined as (1) the area within 500 feet of the work area and (2) areas directed by the Owner. The coverage shall be continuous (i.e., the camera shall not be turned off once photography has begun) to the greatest extent practically possible. If the camera must be turned off then a verbal message shall be inserted stating that the camera will be turned off and the reason for discontinuing coverage.

- C. Visibility

No recording shall be done during periods of significant precipitation, mist or fog. The recording shall only be done when sufficient sunlight is present to properly illuminate the subjects of recording.

- D. Experience

The operator in charge must have had previous experience video documenting a minimum of fifty miles of pre-construction work. Any apprentice operators must be continuously supervised by an above-described experienced operator.

3.04 DELIVERY OF PHOTOGRAPHS

- A. Preconstruction photographs shall be delivered to the Engineer prior to the mobilization of any equipment or materials or the beginning of construction on each pump station site.

- B. Deliver progress prints to Engineer to accompany each Application for Payment.

3.05 DELIVERY OF VIDEO

- A. Recording Schedule

The recording shall be performed prior to the placement of any construction materials or equipment on the proposed construction site, but not more than seven weeks prior to the placement of materials or equipment.

- B. After approval of videos, deliver two record copies to Engineer.

- C. Unacceptable Documentation

The Owner shall have the authority to reject all or any portion of the DVD documentation not conforming to the specifications. Those rejected portions shall be retaped at no additional cost to the Owner.

- D. Specification Deviations

Any deviation from these specifications must have the written approval of the Owner/Engineer.

- E. Payment

There will be no separate payment for construction photographs and videos. Payment for the work covered under this section shall be included within the pay item for mobilization and demobilization. Video documentation will be made in accordance with the project specifications.

END OF SECTION

SECTION 01410

TESTING LAB SERVICES

PART 1 - GENERAL

1.01 REQUIREMENTS INCLUDED

Contractor shall employ and pay for the services of an independent testing laboratory to perform specified testing as required by the specifications.

- 1) The Contractor shall coordinate with the laboratory to facilitate the execution of its required services.
- 2) Employment of the laboratory shall in no way relieve the Contractor's obligations to perform the work of the contract.

1.02 RELATED REQUIREMENTS

- A. Conditions of the contract: Inspections and testing required by laws, ordinances, rules, regulations, orders or approvals of public authorities.
- B. Respective sections of Specifications: Certification of products.

1.03 LABORATORY DUTIES

- A. Cooperate with the Engineer and Contractor to provide certified personnel after due notice.
- B. Perform specified inspections, sampling and testing of materials and methods of construction:
 - 1) Comply with specified standards.
 - 2) Ascertain compliance of materials with requirements of Contract Documents.
- C. Promptly notify the Engineer and Contractor of observed irregularities or deficiencies of work or products.
- D. Promptly submit one (1) hard copy and one (1) electronic copy of written report of each test and inspection to the Engineer, and one (1) hard copy and one (1) electronic copy to the owner. Each report shall include:
 - 1) Date issued.
 - 2) Project title and number.
 - 3) Testing laboratory name, address and telephone number.

- 4) Name and signature of laboratory inspector.
- 5) Date and time of sampling or inspection.
- 6) Record of temperature and weather conditions.
- 7) Date of test.
- 6) Identification of product and specification section.
- 9) Location of sample or test in the project.
- 10) Type of inspection or test.
- 11) Results of test and compliance with Contract Documents.
- 12) Interpretation of test results, when requested by the Engineer.

E. Perform additional tests as required by the Engineer or Owner.

1.04 LIMITATIONS OF AUTHORITY OF TESTING LABORATORY

Laboratory is not authorized to:

- 1) Release, revoke, alter or enlarge on requirements of Contract Documents.
- 2) Approve or accept any portion of the work.
- 3) Perform any duties of the Contractor.

1.05 CONTRACTOR'S RESPONSIBILITIES

- A. Cooperate with laboratory personnel; provide access to work, and to manufacturer's operations.
- B. Secure and deliver to the laboratory, when requested by the Engineer, adequate quantities of representational samples of materials proposed to be used and which require testing.
- C. Provide to the laboratory the preliminary design mix proposed to be used for concrete and other materials mixes which require control by the testing laboratory.
- D. Furnish copies of products test reports as required.
- E. Furnish incidental labor and facilities:
 - 1) To provide access to work to be tested.
 - 2) To obtain and handle samples at the project site or at the source of the product to be tested.
 - 3) To facilitate inspections and tests.
 - 4) For storage and curing of test samples.

F. Notify laboratory sufficiently in advance of operations to allow for laboratory assignment of personnel and scheduling of tests. When tests or inspections cannot be performed after such notice, contractor shall be responsible for laboratory personnel time and travel expenses incurred due to Contractor's negligence.

G. Make arrangements with the laboratory and pay for additional samples and tests required for Contractor's convenience.

H. Contractor to pay for all retesting as a result of test failure.

PART 2 PRODUCTS (NOT USED)

PART 3 EXECUTION (NOT USED)

END OF SECTION

SECTION 01600

MATERIAL AND EQUIPMENT

PART 1 - GENERAL

1.01 REQUIREMENTS INCLUDED

A. Material and equipment incorporated into the work:

- 1) Conform to applicable specifications and standards.
- 2) Comply with size, make, type and quality specified, or as specifically approved, in writing, by the Engineer.
- 3) Manufactured and Fabricated Products:
 - (a) Design, fabricate and assemble in accord with the best engineering and shop practices.
 - (b) Manufacture like parts of duplicate units to standard sizes and gages, to be interchangeable.
 - (c) Two or more items of the same kind shall be identical, by the same manufacturer.
 - (d) Products shall be suitable for service conditions.
- 4) Do not use material or equipment for any purpose other than that for which it is designed or is specified.

1.02 RELATED REQUIREMENTS

- A. Conditions of the Contract
- B. Section 01010: Summary of Work
- C. Section 01340: Shop Drawings, Product Data and Samples

1.03 MANUFACTURER'S INSTRUCTIONS

- A. When Contract Documents require that installation of work shall comply with manufacturer's printed instructions, obtain and distribute copies of such instructions to parties involved in the installation, including two copies to the Engineer.
 - 1) Maintain one set of complete instructions at the job site during installation and until completion.

- B. Handle, install, connect, clean, condition and adjust products in strict accord with such instructions and in conformity with specified requirements.
 - 1) Should job conditions or specified requirements conflict with manufacturer's instructions, consult with Engineer for further instructions.
 - 2) Do not proceed with work without clear instructions.
- C. Perform work in accord with manufacturer's instructions. Do not omit any preparatory step or installation procedure unless specifically modified or exempted by Contract Documents.

1.04 TRANSPORTATION AND HANDLING

- A. Arrange deliveries of products in accord with construction schedules; coordinate to avoid conflict with work and conditions at the site.
 - 1) Deliver products in undamaged condition, in manufacturer's original containers or packaging, with identifying labels intact and legible.
 - 2) Immediately upon delivery, inspect shipments to assure compliance with requirements of Contract Documents and approved submittals, and that products are properly protected and undamaged.
- B. Provide equipment and personnel to handle products by methods to prevent soiling or damage to products or packaging.

1.05 STORAGE AND PROTECTION

- A. Store products in accord with manufacturer's instructions, with seals and labels intact and legible.
 - 1) Store products subject to damage by the elements in weathertight enclosure.
 - 2) Maintain temperature and humidity within the ranges required by manufacturer's instructions.
- B. Exterior Storage
 - 1) Store loose granular materials in a well-drained area on solid surfaces to prevent mixing with foreign matter and entrance to drainage systems.
- C. Arrange storage in a manner to provide easy access for inspection. Make periodic inspections of stored products to assure that products are maintained under specified conditions, and free from damage or deterioration.

D. Protection after Installation

- 1) Provide substantial coverings as necessary to protect installed products from damage from marine traffic and subsequent construction operations. Remove when no longer needed.

1.06 SUBSTITUTIONS AND PRODUCT OPTIONS

A. Products List

- 1) Within 30 days after contract date, submit to the Engineer a complete list of major products proposed to be used, with the name of the manufacturer, supplier, and the installing subcontractor.

B. Contractor's Options

- 1) For products specified only by reference standard, select any product meeting that standard.
- 2) For products specified by naming several products or manufacturers, select any one of the products or manufacturers named, which complies with the specifications.
- 3) For products specified by naming one or more products or manufacturers and "or equal", Contractor must submit a request as for substitutions for any product or manufacturer not specifically named.

PART 2 - PRODUCTS (NOT USED)

PART 3 - EXECUTION (NOT USED)

END OF SECTION

SECTION 01700

CONTRACT CLOSEOUT

PART 1 - GENERAL

1.01 REQUIREMENTS INCLUDED

Comply with requirements stated in Conditions of the Contract and in specifications for administrative procedures in closing out the work.

1.02 RELATED WORK SPECIFIED ELSEWHERE

- A. Conditions of the Contract: Fiscal provisions, legal submittals and additional administrative requirements.
- B. Section 01720: Project Record Documents.
- C. Section 01740: Warranties and Bonds.

1.03 SUBSTANTIAL COMPLETION

- A. When the Contractor considers the work is substantially complete, he shall submit to the Engineer:
 - 1) A written notice that the work, or designated portion thereof, is substantially complete.
 - 2) A list of items to be completed or corrected.
- B. Within a reasonable time after receipt of such notice, the Engineer will make an inspection to determine the status of completion.
- C. Should the Engineer determine that the work is not substantially complete:
 - 1) The Engineer will promptly notify the Contractor, in writing, giving the reasons therefore.
 - 2) The Contractor shall remedy the deficiencies in the work, and send a second written notice of substantial completion to the Engineer.
 - 3) The Engineer will reinspect the work.
- D. When the Engineer finds that the work is substantially complete, he will:

- 1) Prepare and deliver to the Owner a tentative Certificate of Substantial Completion on the appropriate parish form with - a tentative list of items to be completed or corrected before final payment.
- 2) After consideration of any objections made by the Owner as provided in Conditions of the Contract, and when the Engineer considers the work substantially complete, he will execute and deliver to the Owner and the contractor a definite Certificate of Substantial Completion with a revised tentative list of items to be completed or corrected.

1.04 FINAL INSPECTION

- A. When Contractor considers the work is complete, he shall submit written certification that:
 - 1) Contract Documents have been reviewed.
 - 2) Work has been inspected for compliance with Contract Documents.
 - 3) Work has been completed in accordance with Contract Documents.
 - 4) Work is completed and ready for final inspection.
- B. Engineer will make an inspection to verify the status of completion with reasonable promptness after receipt of such certification.
- C. Should Engineer consider that the work is incomplete or defective:
 - 1) Engineer will promptly notify the contractor, in writing, listing the incomplete or defective work.
 - 2) Contractor shall take immediate steps to remedy the stated deficiencies and send a second written certification to Engineer that the work is complete.
 - 3) Engineer will reinspect the work.
- D. When the Engineer finds that the work is acceptable under the Contract Documents, he shall request the Contractor to make closeout submittals.

1.05 FINAL ADJUSTMENT OF ACCOUNTS

- A. Submit a final statement of accounting to the Engineer.
- B. Statement shall reflect all adjustments to the Contract Sum:
 - 1) The original Contract Sum.

- 2) Additions and deductions resulting from:
 - (a) Previous Change Orders
 - (b) Unit Prices
 - (c) Penalties and Bonuses
 - (d) Deductions for liquidated damages
 - (e) Deductions for reinspection payments
 - (f) Other adjustments
- 3) Total Contract Sum, as adjusted.
- 4) Previous payments.
- 5) Sum remaining due.

C Engineer will prepare a final Change order, reflecting approved adjustments to the contract sum which are not previously made by change orders.

1.06 FINAL APPLICATION FOR PAYMENT

Contractor shall submit the final application for payment in accordance with procedures and requirements stated in the Conditions of the Contract.

1.07 CONTRACTOR'S CLOSEOUT SUBMITTALS TO ENGINEER

- A. Project Record Documents.
- B. Warranties and Bonds.
- C. Evidence of Payment and Release of Liens: To requirements of General and Supplementary conditions.
- D. Certificates of Insurance for Products and Completed operations.
- E. As-Built Drawings.
- F. Maintenance Manuals.

PART 2 - PRODUCTS (NOT USED)

PART 3 - EXECUTION (NOT USED)

END OF SECTION

SECTION 01720

PROJECT RECORD DOCUMENTS

PART 1 - GENERAL

1.01 DESCRIPTION

The Contractor shall maintain at the site for the Owner's permanent records one copy of:

1. Drawings.
2. Specifications.
3. Addenda.
4. Change Orders and other Modifications to the Contract.
5. Engineer Field Orders or Written Instructions.
6. Approved Shop Drawings, Product Data.
7. Field Test Records.
8. Construction Photographs.

1.02 RELATED WORK SPECIFIED ELSEWHERE

- A. Section 01340: Shop Drawings, Product Data and Samples.
- B. Section 01700: Contract Closeout.

PART 2 - PRODUCTS (NOT USED)

PART 3 - EXECUTION

3.01 MAINTENANCE OF DOCUMENTS AND SAMPLES

- A. The Contractor shall store documents and samples in his office apart from documents used for construction.
- B. The Contractor shall maintain documents in a clean, dry, legible condition and in good order. Do not use record documents for construction purposes.
- C. The Contractor shall make documents and samples available at all times for inspection by the Engineer and Owner.

3.02 MARKING-UP RECORD DRAWINGS

The Contractor shall mark with red erasable pencil and, where necessary, use other pencil colors, as required.

3.03 RECORDING

- A. Label each document (including record prints and shop drawings) "PROJECT RECORD" in neat large printed letters.
- B. Record information concurrently with construction progress. Do not conceal any work until required information is recorded.
- C. Drawings. Legibly mark field drawings to record actual construction:
 - 1. Location of internal utilities and appurtenances concealed in the construction, referenced to visible and accessible features of the structure.
 - 2. Field changes of dimensions and details.
 - 3. Changes made by change order.
 - 4. Details not on original Contract Drawings.
- D. Specifications and Addenda. The Contractor shall legibly mark each Section to record:
 - 1. Manufacturer, trade name, catalog number and supplier of each product and item of equipment actually installed.
 - 2. Changes made by Field Order or by Change Order.

3.04 SUBMITTALS

- A. At Contract close-out deliver record documents to the Engineer including marked-up drawings, as-built survey, specifications, addenda, change orders and other modifications to contract; Engineers field orders and written instructions, approved shop drawings, product data, field test records and any other documents which serve as a record of actual field installation and construction different from the original contract documents. Engineer will submit them to Owner.
- B. Accompany submittals with transmittal letters in duplicates containing:
 - 1. Date
 - 2. Project title and number
 - 3. Contractor's name and address
 - 4. Title and number of each Record Document
 - 5. Signature of Contractor or his authorized representative

END OF SECTION

SECTION 01740

WARRANTIES AND BONDS

PART 1 - GENERAL

1.01 REQUIREMENTS INCLUDED

- A. Compile specified warranties and bonds.
- B. Compile specified service and maintenance contracts.
- C. Co-execute submittals when so specified.
- D. Review submittals to verify compliance with Contract Documents.
- E. Submit to Engineer for review and transmittal to owner.

1.02 RELATED REQUIREMENTS

- A. Instructions to Bidders: Bid or Proposal Bonds.
- B. Conditions of the Contract: Performance Bond and Labor and Material Payment Bond.
- C. Conditions of the Contract: General Warranty of Construction.
- D. Section 01700: Contract Closeout.

1.03 SUBMITTAL REQUIREMENTS

- A. Assemble warranties, bonds and service and maintenance contracts, executed by each of the respective manufacturers, suppliers, and subcontractors.
- B. Number of original signed copies required: Two (2) each.
- C. Table of Contents: Neatly typed, in orderly sequence. Provide complete information for each item.
 - 1. Product or work item.
 - 2. Firm, with name of principal, address and telephone number.
 - 3. Scope.
 - 4. Date of beginning of warranty, bond or service and maintenance contract.
 - 5. Duration of warranty, bond, or service maintenance contract.
 - 6. Provide information for Owner's personnel:
 - a. Proper procedure in case of failure.
 - b. Instances which might affect the validity of warranty or bond.
 - 7. Contractor, name of responsible principal, address and telephone number.

1.04 FORM OF SUBMITTALS

- A. Prepare in duplicate packets.
- B. Format:
 - 1. Size 8 ½” x 11”, punch sheets for standard 3-ring binder. Fold larger sheets to fit into binders.
 - 2. Cover: Identify each packet with typed or printed title "WARRANTIES AND BONDS". List:
 - a. Title of project.
 - b. Name of Contractor.
- C. Binders: Commercial quality, 3-ring, with durable and cleanable plastic covers.

1.05 TIME OF SUBMITTALS

- A. Make submittals within ten days after Date of Substantial Completion, prior to final request for payment.
- B. For items of work, where acceptance is delayed materially beyond Date of Substantial Completion, provide updated submittal within ten days after acceptance, listing date of acceptance as start of warranty period.

1.06 SUBMITTALS REQUIRED

Submit warranties, bonds, service and maintenance contracts as specified in respective sections of specifications.

PART 2 - PRODUCTS (NOT USED)

PART 3 - EXECUTION (NOT USED)

END OF SECTION

SECTION 02140

MOBILIZATION

1.01 DESCRIPTION

This work consists of preparatory work and operations, including those necessary for movement of personnel, equipment, supplies and incidental to the project site; the establishment of facilities necessary for the work on the project; the costs of bonds and any required insurance; and other preconstruction expenses necessary for start of the work, excluding the cost of construction materials. This work also includes performance of a magnetometer survey to be performed prior to commencement of the work.

As part of mobilization, Contractor shall provide marine transport from the nearest boat launch facilities to and from the site for the OWNER/ENGINEER'S resident project representative at the beginning and end of each workday. Marine transport shall also be provided for OWNER and ENGINEER for progress meetings.

This work shall be performed in accordance with Section 727 of the Louisiana Standard Specifications for Roads and Bridges, latest edition and its latest revisions.

1.02 MEASUREMENT AND PAYMENT

- A. Measurement: Measurement for payment for mobilization and demobilization will be on a lump-sum basis as specified herein.
- B. Payment: Payment for mobilization and demobilization shall cover all preparatory work, obtaining all permits, insurance and bonds, movement of personnel, equipment, supplies and incidentals to the project site, preconstruction photographs and videos, the establishment of temporary offices, magnetometer survey, and other construction facilities necessary for work on this project. It shall include removal of all personnel, equipment, supplies and incidentals from the project site, removal of temporary offices and other construction facilities necessary for work on this project, all as required for the proper performance and completion of the work. Payment will be made at the contract lump sum price, subject to the following provisions:

Partial payments for mobilization and demobilization will be made in accordance with the following schedule up to a maximum of 10 percent of the total contract amount (including this item), and payment of any remaining amount will be made upon completion of all work under the contract.

<u>Percent of Total Contract Amount Earned</u>	<u>Allowable Percent of the Lump Sum Price for the Item</u>
1 st Partial Estimate	25%

10%
25%
50%

50%
75%
100%

No price adjustments will be made for this item due to changes in the work.

END OF SECTION

SECTION 02240

GEOTEXTILE FABRIC

1.1 SCOPE

The work provided for herein consists of furnishing all labor, material, equipment, and performing all operations required for furnishing, hauling, and placing the woven geotextile fabric, complete, as specified herein and on the plans, and maintaining the geotextile until the project is completed and accepted.

1.2 APPLICABLE PUBLICATIONS

The current issues of the ASTM publications listed below, referred to there after by basic designation only, form a part of this specification to the extent indicated by the references thereto:

D 883-92	Relating to Plastics
D 1683-90a	Failure In Seams Of Woven Fabrics
D 4439-92a	Geosynthetics
D 4491-89	Water Permeability of Geotextiles By Permittivity
D 4632-91	Grab Breaking Load and Elongation of Geotextiles
D 4751-87	Determining Apparent Opening Size of a Geotextile

1.3 MATERIALS

Geotextile shall be composed of high-tenacity polypropylene yarns, which are woven into a network such that the yarns retain their relative position. Geotextile shall be inert to biological degradation and resistant to naturally encountered chemicals, alkalis, and acids.

Geotextile fabric shall consist of the following minimum specifications:

Mechanical Properties	Test Method	Units	Minimum Average Roll Value	
			MD	CD
Tensile Strength (at 2% strain)	ASTM D-4595	kN/m (lbs/ft)	8.5 (580)	8.5 (580)
Tensile Strength (at 5% strain)	ASTM D-4595	kN/m (lbs/ft)	17.5 (1200)	17.5 (1200)
Factory Seam Strength	ASTM D-4884	kN/m (lbs/ft)	21.9 (1500)	
UV Resistance (at 500 hours)	ASTM D-4355	% strength retained	70	
Grab Tensile Strength	ASTM D-4632	kN (lbs)	1.8 (405)	1.4 (315)
Grab Tensile Elongation	ASTM D-4632	%	15	6
Trapezoid Tear Strength	ASTM D-4533	kN (lbs)	0.67 (150)	0.80 (180)
Mullen Burst Strength	ASTM D-3786	kPa (psi)	4130 (600)	
Puncture Strength	ASTM D-4833	kN (lbs)	0.53 (120)	

1.4 MATERIAL SOURCES

Geotextile fabric shall meet or exceed the above minimum specifications.

1.5 SHIPMENT AND STORAGE

The geotextile shall be shipped and maintained in a heavy duty protective cover until it is placed. During all periods of shipment and storage, the geotextile shall be protected from direct sunlight, ultra-violet rays, temperatures greater than 140 degrees Fahrenheit, mud, dirt, and other contaminants.

1.6 SEAMS AND END LAPS

Seams will be utilized to produce panels of geotextile large enough to cover the area shown on the drawings.

- A. Seams. The sheets of geotextile shall be sewn at the factory or other approved location. Seam strengths shall meet the requirements of Section 1.3.
- B. End Laps. Geotextile panels placed parallel to the centerline shall be overlapped at their ends a minimum of three (3) feet.

1.7 INSTALLATION

The geotextile shall be placed in the manner and at the locations shown on the drawings. The CONTRACTOR shall prepare the surface to receive the geotextile to insure that the surface is relatively smooth and free of obstructions, depressions, debris, or stone which could damage the geotextile during placement. At the time of installation, the geotextile shall be rejected if it has defects, rips, holes, flaws, deterioration or damage incurred during manufacture, transportation or storage. The geotextile shall be protected at all times during construction to insure that the geotextile's original chemical and physical properties are not changed. The work shall be scheduled so that all of the geotextile that is placed is covered with a layer of the specified material by the end of each workday. Failure to comply shall require replacement of geotextile. All wrinkles and sags shall be stretched out immediately before stone is placed on the geotextile. The geotextile shall be protected from damage during placement of stone. This shall be accomplished by limiting the height of drop to less than one (1) foot or the water surface, whichever is greater. In the event that this damages the geotextile, the stone shall be placed directly on the geotextile with zero (0) height of drop. Before placement of stone, the CONTRACTOR shall demonstrate that the placement technique will not damage the geotextile. Any geotextile that is rejected or damaged shall be replaced by the CONTRACTOR at no additional cost to the OWNER.

1.8 ACCEPTANCE

All approved brands of geotextile and all seams used in construction will be accepted on the following basis. At least thirty (30) days prior to installation, the CONTRACTOR shall furnish to the ENGINEER, in duplicate, a mill certificate or affidavit signed by a legally authorized official from the company manufacturing the geotextile. The certificate shall contain the signer's title, the name and address of the CONTRACTOR, the contract number, and the project name and location. The mill certificate or affidavit shall attest that the geotextile meets the chemical, physical, and manufacturing requirements stated in this specification and that the seams used meet the seam requirements. A three (3) foot by three (3) foot sample of each geotextile that the CONTRACTOR plans to use shall accompany the certificate. If seams are used, then an additional three (3) foot by three (3) foot sample containing a sample seam in the center of the geotextile sample shall be submitted with the certificate.

1.9 MEASUREMENT AND PAYMENT

Geotextile will be measured in place to the nearest square yard of protected area as delineated on the drawings. Overlaps will be measured as a single layer. Payment will be made at the applicable contract unit price for "Geotextile Fabric" per square yard. Price and payment shall constitute full compensation for providing all plant, labor, material, and equipment and performing all operations

necessary for the complete and satisfactory installation of the geotextile. No payment shall be made for geotextile that is rejected or damaged due to CONTRACTOR fault or negligence.

END OF SECTION

SECTION 02270

RIP-RAP

1.1 DESCRIPTION

This work consists of furnishing and placing graded stone rip-rap in accordance with these specifications and in conformity to lines, grades and thickness shown on the plans or as directed by ENGINEER.

1.2 MATERIALS

Rip-rap shall consist of stone that will not disintegrate upon exposure to the elements or be easily broken from handling and shall be reasonably free from each and other foreign materials. When tested in accordance with AASHTO Designation: T 85, the solid weight of stone shall be at least 150 pounds per cubic foot (based on the bulk specific gravity) and the absorption shall not exceed two percent. Samples of stone shall be taken under supervision of the ENGINEER and submitted for testing and approval prior to delivery to the project when so requested.

The gradation limits define a gradation band and Class C stone meeting the gradation falling within the band is acceptable. Neither the width nor the thickness of any piece of stone shall be less than one-third its length. Methods of stockpiling and removal of rip-rap shall be submitted to the ENGINEER for approval.

The primary armor layer rip rap shall be in accordance with the U.S. Corps of Engineers Mississippi River Division Standard Riprap Gradations for “clean” riprap R1500. The armor layer gradation is specified in detail below:

Primary Armor Layer Rip Rap Gradation

Percent Lighter by Weight (Pounds)	Gradation Limits Individual Stone Weight (Pounds)	
	Upper Limit	Lower Limit
100	1500	600
50	650	300
15	330	100

The core layer rip rap shall be in accordance with the U.S. Corps of Engineers Mississippi River Division Standard Riprap Gradations for “clean” riprap R650. The core layer gradation is specified in detail below:

Core Layer Rip Rap Gradation

Percent Lighter by Weight (Pounds)	Gradation Limits Individual Stone Weight (Pounds)	
	Upper Limit	Lower Limit
100	650	260
50	280	130
15	130	40

Rip rap used for scour protection shall be in accordance with the U.S. Corps of Engineers Mississippi River Division Standard Riprap Gradations for “clean” riprap R200. The scour protection gradation is specified in detail below:

Scour Protection Rip Rap Gradation

Percent Lighter by Weight (Pounds)	Gradation Limits Individual Stone Weight (Pounds)	
	Upper Limit	Lower Limit
100	200	80
50	80	40
15	40	10

1.3 CONSTRUCTION REQUIREMENTS

Areas on which heavy deposited rip-rap is to be placed shall be graded to required sections. Heavy deposited rip-rap shall be placed and uniformly distributed over the areas. If placement in water currents is required, the CONTRACTOR shall make drift checks and place rip-rap in such manner as to compensate for drift. The CONTRACTOR shall furnish necessary facilities and personnel for checking rip-rap depth and distribution.

A tolerance of plus or minus six inches from the finished grades shown on the drawings will be allowed in the finished surface of the rip-rap. The extreme of either tolerance shall not be continuous over a length greater than 20 feet.

1.3.1 Placing Crushed Stone and Rip Rap

Rip-rap and crushed stone should be placed along the centerline of the new section and worked outward. As placement is advanced from the center outward, mud waves should be removed if stone placement is hindered. Rip-rap or crushed stone shall not be dropped from the water surface. It shall be placed directly above the mudline. Rip-rap and crushed stone shall be advanced simultaneously forward along the centerline of the new section and worked outward perpendicular to the centerline. Additional removal of mud waves may be required if not placed in a center to outward manner. It shall be placed in lifts no greater than 3 feet until the fill reaches above the water surface. Placement above the water surface shall be in 2 foot lifts. Rip-rap shall be placed to its full course thickness in one operation and in such manner as to avoid displacing the bedding material. Placing rip-rap by dumping it at the top of the slope and pulling it down the embankment slope will not be permitted.

1.3.2 Protection of Structures

When placing rip-rap adjacent to structures, care shall be exercised to avoid damage to the structure. The ENGINEER will inspect the placement of the rip-rap to insure that the finished sections are in conformance with the plans or as directed.

1.4 METHODS OF MEASUREMENT

Rip-rap shall be measured by the ton (2,000 pounds). Quantities will be computed to the nearest tenth of a ton. If rip-rap is delivered by truck, measurement will be based on certified weight tickets furnished to the ENGINEER by the CONTRACTOR. If rip-rap is delivered by barge, measurement will be made by calculation from barge displacement in a manner acceptable to the ENGINEER, based on water 62.4 pounds per cubic foot.

1.5 BASIS OF PAYMENT

Rip-rap will be paid for at the contract unit prices for "Rip Rap" per ton. Price and Payment shall include all costs of furnishing, hauling, handling and placing to the lines and grades as shown on the plans.

END OF SECTION

SECTION 02272

GEOGRID

1.1 SCOPE

This work consists of furnishing and installing Geogrid in accordance with the specifications as shown on the plans or directed by the Engineer.

1.2 MATERIALS

The Geogrid shall consist of the following minimum specifications:

The Geogrid shall be integrally formed structural geogrid by biaxially drawing a continuous sheet of high density polyethylene material and shall permit positive mechanical interlock with the material being reinforced. The Geogrid shall have high flexural rigidity and high tensile modulus in relation to the material being reinforced and shall also have high continuity of tensile strength through all ribs and junctions of the grid structure. The Geogrid shall maintain its reinforcement and interlock capabilities under repeated dynamic loads while in service and shall also be resistant to ultraviolet degradation, to damage under normal construction practices, and to all forms of biological or chemical degradation normally encountered in the material being reinforced.

The Geogrid shall also conform in all respects to the property requirements listed below.

PRODUCT PROPERTIES

	Units	MD Values¹	XMD Values¹
Index Properties			
Aperture Dimensions ²	mm (in)	25 (1.0)	30.5 (1.2)
Minimum Rib Thickness ²	mm (in)	1.78 (0.07)	1.78 (0.07)
Tensile Strength @ 2% Strain ³	kN/m (lb/ft)	8.5 (580)	10.0 (690)
Tensile Strength @ 5% Strain ³	kN/m (lb/ft)	17.5 (1,200)	20.0 (1,370)
Ultimate Tensile Strength ³	kN/m (lb/ft)	27 (1,850)	30.0 (2,050)
Structural Integrity			
Junction Efficiency ⁴	%	93	
Flexural Stiffness ⁵	mg-cm	2,000,000	
Aperture Stability ⁶	m-N/deg	0.75	
Durability			
Resistance to Installation Damage ⁷	%SC / %SW / %GP	95 / 93 / 90	
Resistance to Long Term Degradation ⁸	%	100	
Resistance to UV Degradation ⁹	%	100	

Dimensions and Delivery

The structural geogrid shall be delivered to the jobsite in roll form with each roll individually identified and nominally measuring 13.1 feet in width and 164 feet in length. A typical truckload quantity is 180 rolls.

Notes

1. Unless indicated otherwise, values shown are minimum average roll values determined in accordance with ASTM D4759-02. Brief descriptions of test procedures are given in the following notes.
2. Nominal dimensions.
3. True resistance to elongation when initially subjected to a load determined in accordance with ASTM D6637-01 without deforming test materials under load before measuring such resistance or employing "secant" or "offset" tangent methods of measurement so as to overstate tensile properties.
4. Load transfer capability determined in accordance with GRI-GG2-05 and expressed as a percentage of ultimate tensile strength.
5. Resistance to bending force determined in accordance with ASTM D5732-01, using specimens of width two ribs wide, with transverse ribs cut flush with exterior edges of longitudinal ribs (as a "ladder"), and of length sufficiently long to enable measurement of the overhang dimension. The overall Flexural Stiffness is calculated as the square root of the product of MD and XMD Flexural Stiffness values.
6. Resistance to in-plane rotational movement measured by applying a 20 kg-cm (2 m-N) moment to the central junction of a 9 inch x 9 inch specimen restrained at its perimeter in accordance with U.S. Army Corps of Engineers Methodology for measurement of Torsional Rigidity.
7. Resistance to loss of load capacity or structural integrity when subjected to mechanical installation stress in clayey sand (SC), well graded sand (SW), and crushed stone classified as poorly graded gravel (GP). The geogrid shall be sampled in accordance with ASTM D5818-06 and load capacity shall be determined in accordance with ASTM D6637-01.
8. Resistance to loss of load capacity or structural integrity when subjected to chemically aggressive environments in accordance with EPA 9090 immersion testing.
9. Resistance to loss of load capacity or structural integrity when subjected to 500 hours of ultraviolet light and aggressive weathering in accordance with ASTM D4355-05.

1.3 MATERIAL SOURCES

Geogrid shall be Biaxial Geogrid BX1500 as manufactured by Tensar Corp., Mirafi BXG150 as manufactured by TenCate Geosynthtics, or approved equal.

1.4 INSTALLATION

The geogrid shall be placed in the manner and at the locations shown on the drawings. The CONTRACTOR shall prepare the surface to receive the geogrid to insure that the surface is relatively smooth and free of obstructions, depressions, debris, soft or low density pockets of material, or stone which could damage the geogrid during placement. Should overlaps of the

geogrid be required, overlaps shall be at least three (3) feet. At the time of installation, the geogrid shall be rejected if it has defects, rips, holes, flaws, deterioration or damage incurred during manufacture, transportation or storage. The geogrid shall be protected at all times during construction to insure that the geogrid's original chemical and physical properties are not changed. The work shall be scheduled so that all of the geogrid that is placed is covered with a layer of the specified material by the end of each workday. Failure to comply shall require replacement of geogrid. All wrinkles and sags shall be stretched out immediately before stone is placed on the geogrid. The geogrid shall be protected from damage during placement of stone. This shall be accomplished by limiting the height of drop to less than one (1) foot or the water surface, whichever is less. In the event that this damages the geogrid, the stone shall be placed directly on the geogrid with zero (0) height of drop. Before placement of stone, the CONTRACTOR shall demonstrate that the placement technique will not damage the geogrid. Any geogrid that is rejected or damaged shall be replaced by the CONTRACTOR at no additional cost to the OWNER.

1.5 ACCEPTANCE

All brands of geogrid and all seams used in construction will be accepted on the following basis. At least fifteen (15) days prior to installation, the CONTRACTOR shall furnish to the ENGINEER, in duplicate, a mill certificate or affidavit signed by a legally authorized official from the company manufacturing the geogrid. The certificate shall contain the signer's title, the name and address of the CONTRACTOR, the contract number, and the project name and location. The mill certificate or affidavit shall attest that the geogrid meets the chemical, physical, and manufacturing requirements stated in this specification and that the seams used meet the seam requirements. A three (3) foot by three (3) foot sample of each geogrid that the CONTRACTOR plans to use shall accompany the certificate. If seams are used, then an additional three (3) foot by three (3) foot sample containing a sample seam in the center of the geogrid sample shall be submitted with the certificate.

1.6 MEASUREMENT AND PAYMENT

Geogrid will be measured in place to the nearest square yard of protected area as delineated on the drawings. Overlaps will be measured as a single layer. Payment will be made at the applicable contract unit price for "Geogrid" per square yard. Price and payment shall constitute full compensation for providing all plant, labor, material, and equipment and performing all operations necessary for the complete and satisfactory installation of the geogrid. No payment shall be made for geogrid that is rejected or damaged due to CONTRACTOR fault or negligence.

END OF SECTION

SECTION 02315

DREDGING, FILL, AND GRADING

1.1 SCOPE

- A. Furnish all labor, materials, equipment and incidentals required and perform all excavation and dredging work and grading; place and compact backfill and fill; and dispose of unsuitable waste and surplus materials as shown in the Drawings and as specified herein.
- B. Provide the services of a licensed professional engineer, registered in the State in which the work is located, to prepare and needed temporary excavation support system designs and submittals.
- C. If needed, furnish and install temporary excavation support systems, including sheeting, shoring and bracing, to ensure the safety of personnel and protect adjacent structures, piping, etc, in accordance with Federal, State and local laws, regulations and requirements.
- D. Dredging shall consist of removing and satisfactorily placing all material required for backfill on the peninsula and, if needed, construct the flotation channel. The limits of dredge work shall conform to the lines and grades shown on the project plans. Tolerances veering from these requirements must be approved by the ENGINEER.
- E. If needed, furnish and install turbidity curtains totally enclosing dredging within watercourses to confine sedimentation within the construction area.

1.2 METHOD

No method of dredging will be specified. The CONTRACTOR will use any environmentally acceptable method that will complete the work in accordance to that shown on the drawings. However, the CONTRACTOR shall submit to the ENGINEER the method and equipment intended to be used to complete dredging of flotation channels.

1.3 DISPOSAL

Dredged material shall be deposited in areas as shown on the drawings or as directed by the ENGINEER. Any material that is deposited elsewhere than as indicated on the plans or as authorized by the ENGINEER shall be required to be removed and deposited in approved areas at the CONTRACTOR's expense. Additionally, the CONTRACTOR will be responsible for restoring unauthorized disposal areas to pre-project conditions at his own expense.

1.4 CONSTRUCTION

Side slopes of the channels shall be cut true to the proper cross sections as indicated on the drawings. The channels shall be maintained to transport equipment and materials to the project area for the duration of the construction.

1.4.1 Dredging of flotation channels will not be allowed within 45 feet of any structure or adjacent bankline unless approved by Engineer.

1.5 TURBIDITY CURTAIN (DEEP)

1.5.1 Description

This work shall consist of furnishing and placing a geosynthetic barrier totally enclosing dredging within watercourses to confine sedimentation within the construction area. The CONTRACTOR shall provide a floating Turbidity Curtain, not silt fence, in depths equal to or greater than 2 feet. The Turbidity Curtain shall be a pre-assembled system, including the geotextile/geomembrane, connection and securing mechanisms, flotation devices, stakes, and ballast chain. The CONTRACTOR shall provide a system of adequate capability, appropriate for the site conditions such as depth (shown on plans), current, and wind/waves. The Turbidity Curtain shall be constructed according to this specification, and the details shown on the plans.

1.5.2 Materials

1.5.2.1 Geosynthetic

The geosynthetic shall meet the minimum physical requirements for Stabilization Geotextile, except the permittivity (ASTM D 4491) requirement shall be 0.06 sec^{-1} maximum. Geosynthetics may be polymer impregnated to negate permittivity and opening size requirements. Hemmed pockets shall be sewn or heat bonded for flotation devices and bottom weights. Panel ends shall have metal grommets placed through a reinforced hem. Connections between panels shall be tightly tied with synthetic or wire rope to prevent flow through the joint.

1.5.2.2 Flotation

Flotation devices shall be closed-cell polystyrene. The buoyancy (volume) required will depend upon site conditions; however, sufficient freeboard shall be provided to prevent overtopping.

1.5.2.3 Stakes

Stakes, when used to assist in maintaining alignment of the curtain, shall be hardwood or steel with sufficient length and cross-section to support the curtain.

External supports may be used; however, embedment depth shall not be less than 1.5 feet.

1.5.2.4 Hardware

All hardware such as stakes, ballast chain, connection bolts, reinforcement plates, and tension cables shall be galvanized, stainless steel, aluminum, or otherwise corrosion resistant. The ballast chain shall have sufficient mass to maintain the geosynthetic in a vertical position, but shall not be less than 0.7 lb/ft.

1.5.3 Construction Methods

The Turbidity Curtain shall be placed according to locations and depths shown on the plans, details, and according to the manufacturer's published installation guidelines or as directed by the ENGINEER. The Turbidity Curtain system shall be designed to handle site specific drainage or flow appurtenances. The CONTRACTOR shall be responsible to provide and maintain sufficient anchors, tie-downs, or other mechanisms to insure proper position and performance of the Turbidity Curtain. The Turbidity Curtain shall include a redirectional barrier on the upstream end such as a concrete barrier or wood planking. Any visible plume of cloudy water outside the protected construction area shall constitute inadequate performance of the Turbidity Curtain. The CONTRACTOR shall immediately modify, adjust, or repair any portion of Turbidity Curtain to correct inadequate performance.

The floating curtains shall maintain bottom contact. Excess curtain shall lay without wrinkles on the bottom, away from construction activity.

The CONTRACTOR shall maintain the Turbidity Curtain until the construction activity within the watercourse is complete and the turbidity is reduced to acceptable levels as approved by the ENGINEER. Maintaining shall include keeping a tight alignment around the work area or shoreline.

1.6 NAVIGATION

The CONTRACTOR shall mark the channels with buoys and lights in accordance with the rules and regulations of the U.S. Coast Guard and the U.S. Army Corps of ENGINEERS.

1.7 MEASUREMENT AND PAYMENT

BASE BID

Dredging, Fill, and Grading will be paid for at the lump sum price for "Dredging, Fill and Grading". Price and payment shall constitute full compensation for all materials, labor, supplies, and equipment required for dredging approximately 250 cubic yards of material from the

permitted dredge area shown on the plans and placing to on the peninsula to the lines and grades shown on the plans.

Any flotation channel dredging required for access to the site beyond the fill required in the base bid shall be considered incidental to the contractor's mobilization cost for any base bid or alternate. This operation will be considered complete when the remaining disposal material is placed back into the flotation channel and the bottom depth of the temporary disposal area is back to pre-construction conditions and/elevations.

The Turbidity Curtain installation and maintenance shall be incidental to the contractor's mobilization cost. Length required shall be Contractor's means and method to confine sedimentation within the Contractor's dredging area. Price and payment shall constitute full compensation for all materials, labor, supplies, and equipment required for placement of the turbidity curtain and maintaining the curtain for the duration of the construction until the flotation channel has been returned to pre-construction conditions. This operation is considered complete when the turbidity curtain and all associated materials, supplies, and equipment have been removed from the construction area.

END OF SECTION

SECTION 02480

MARINE HAZARD MARKERS

1.1 DESCRIPTION

This work consists of furnishing and installing temporary and permanent marine hazard markers along the length and at the end of breakwater, as depicted in the construction plans and directed by the Engineer in the field. Marine hazard markers shall consist of vertically driven timber poles with reflective tape strips wrapped around and firmly attached to the top, with USCG approved marine lantern with flash characteristic FL2.5S, per the plan details and these specifications.

1.2 MATERIALS

Timber Poles: ASTM D-25, Class 5, Southern Yellow Pine, 50 LF long (Typical) or approved equal, treated per AWWA Standards for USE Classification UC5C – MARINE USE IN SOUTHERN WATERS; said treatment protects timber against Marine Borer attack and decay. This treatment can be provided by CCA as well as Creosote treatments that are appropriate for use in marine waters.

Reflective Tape: 3” Wide, U. S. Coast Guard-Approved, Marine Grade Reflective Tape. 3M USCGFP-30 WHITE, or approved equal. Provide three (3) rows, spaced 4” apart, at top of timber poles, as depicted in the construction plans.

Marine Lantern: USCG approved self-contained solar-powered navigational lantern with flash characteristic FL2.5S (WHITE), omnidirectional, manufactured by Tideland Signal or pre-approved equal.

1.3 INSTALLATION

Pile-Driving Equipment: Hammers for driving timber poles shall be either single or double-acting air, steam or diesel hammers that develop at each full stroke of the piston not less than 7,200, or more than 20,000 foot-pounds of energy per blow. The adequacy of diesel hammers in meeting these energy criteria will be determined by rating the diesel hammer at 85% of the maximum rating specified by the manufacturer.

Equipment shall be constructed in such a manner as to afford freedom of movement of the hammer and to drive poles to the tolerances specified without damage to the poles. Either fixed leads or swinging leads may be utilized. Swinging leads shall only be utilized in combination with a rigid template providing pile support and meeting the approval of the Engineer

Construction Layout: The Contractor shall obtain appropriate services by a professional land-surveying firm that is familiar with operating in South Louisiana’s marine environment, to provide construction layout and positioning of the required marine hazard markers, in strict accordance with the coordinates provided in the construction plans. Before starting Work, the Contractor and his surveyor shall examine the site and check dimensions, locations, etc. Should there be any discrepancies requiring relocation of piles, change in procedure or change in design, report such to Engineer in writing before proceeding with Work.

Installation: Conform to all applicable local, parish, and State rules, regulations, codes, ordinances, and Federal laws including safety regulations.

Treated Timber Poles used for Marine Hazard Markers shall be driven with an approved hammer that will obtain required penetration without damaging poles. The butt of each timber pole before driving shall be cut at right angles to the longitudinal axis of the pole, shall be taper-trimmed, and capped with a standard butt-plate, and shall be additionally banded with iron bands if necessary to prevent brooming during driving.

Drive poles plumb and accurately into position indicated on Drawings; a maximum variation not exceeding 3 inches in more than 10% of the total number of poles will be accepted. Any pole that crushes, splits, or otherwise fails while being driven must be immediately removed and replaced with another pole at the Contractor's expense.

Driving Logs: Log the driving of all poles, recording the date driven, type of hammer, pole description, and driving resistance with the blows per foot for the last 10 feet driven. Furnish 4 copies of the record to the Engineer. Driving shall progress continuously until the planned penetration is reached or until a resistance of 30 blows per foot is achieved.

1.4 MEASUREMENT

The Contractor shall measure all poles prior to driving, and shall note all cut-off lengths, so as to determine the lengths actually driven in the field. The net lengths of poles that are installed for marine hazard markers shall be noted for "AS-BUILT" records, only.

1.5 PAYMENT

Marine Hazard Markers shall be paid for at the contract unit price per each, which price and payment shall be full compensation for furnishing all plant, labor, material, timber poles, equipment and all other incidentals as specified herein and as shown on the drawings.

END OF SECTION

SECTION 05500

METAL FABRICATIONS

1.0 GENERAL

1.01 DESCRIPTION

- A. Fabrication and installation of metal Work not specified elsewhere.
- B. Shop and field welding, drilling, cutting, connecting.
- C. Shop galvanizing.
- D. Anchor bolts to be furnished complete with nuts and washers and inserts for miscellaneous attachment.
- E. Furnish all loose bolts, tag screws, screws, nuts, washers, angles and clip angles of sizes required or where shown for connections to timber structural members, miscellaneous steel, and concrete.
- F. Furnish all gusset plates, bent plates, bearing plates, straight bars, angles, tie rods, and any other items required or where shown for connections to timber structural members, miscellaneous steel, and concrete.
- G. Metal fabrications specified and/or shown on the Drawings and all miscellaneous steel items reasonably implied but not specifically mentioned on the Drawings or specified herein to render Work secure and complete.

1.02 RELATED WORK

- A. Division 6 - Timber

1.03 REFERENCE STANDARDS

- A. ASTM: American Society for Testing and Materials.
- B. AISC: American Institute for Steel Construction.
- C. AWS: American Welding Society.

1.04 SUBMITTALS

- A. Submit shop drawings for review, in accordance with Section 01340, before beginning Work of this Section. Show manner of fabrication of Work and size and extent of welds, bolts, etc.

1.05 QUALITY ASSURANCE

- A. Mill certificates shall be submitted with all fabricated items for the raw materials.

1.06 MEASUREMENT

- A. The size, shape, and thickness of the metal fabrication shall be as shown on the drawings.
- B. No measurement shall be made for metal fabrications.

1.07 PAYMENT

Payment for Metal Fabrication shall be included in the lump sum price.

2.0 PRODUCTS

2.01 MATERIALS

- A. All Steel: ASTM A-36, Galvanized.
- B. All Plain Steel Bolts, nuts, and washers: ASTM A-307 or A-36 Hot Dipped Galvanized.
- C. All Stainless Steel Bolts, nuts, and washers: ASTM A-304.

2.02 FABRICATION

- A. General: Work shall be shop-fitted and shop-assembled where practicable, as detailed in reviewed shop drawings. Follow applicable AISC codes and manuals. Finish exposed Work smooth with even, close joints and neat connections. Profiles shall be true to detail, clean, straight, and sharply-defined.
- B. Preparation: Clean material before fabrication.

- C. Cutting and drilling: Provide drilled or punched holes only for fabrication and galvanizing and for attachment of Work specified elsewhere. Countersink holes for rivets and screws. Saw or punch cut steel used for structural purposes.
- D. Galvanizing (where indicated) shall be hot-dipped galvanized after fabrication in accordance with the Standard Specifications of the American Hot Dip Galvanizers Association. Members indicated shall receive a heavy hot dip zinc coating in compliance with ASTM A 123 or shall be accomplished by an approved galvanizing method complying with ASTM B 695, with a minimum coating of 1.5 ounces of zinc per square foot of metal surface. The coating shall have a uniform thickness, free of uncoated spots or dross.
- E. Welding:
 - 1. Weld joints continuous unless otherwise noted and grind welds smooth.
 - 2. Use E70 Series or E70XX Electrodes.

2.03 ANCHORS, BOLTS, AND FASTENING DEVICES

- A. Anchors, bolts, etc., shall be furnished as necessary for installation of the work of this Section.
- B. The bolts used to attach the various members to the anchors shall be the sizes shown or required.

3.0 EXECUTION

- A. Furnish dimensions and instructions for setting of embedded items as required in other Sections.
- B. Erect all work plumb, square, and true. Fit accurately with tight joints and intersections. Brace, reinforce, and anchor in place.
- C. Repair damaged galvanized coatings using an approved cold galvanizing repair compound applied in accordance with manufacturer's requirements.

END OF SECTION

SECTION 06100

ROUGH CARPENTRY

1.0 GENERAL

1.01 DESCRIPTION

- A. Include all labor, materials, services, supervision, quality control, equipment, tools and transportation necessary to complete all wood joists, stringers, posts, beams, pile caps, decking, railing, blocking, cants, grounds, bracing, and nailers.

1.02 RELATED WORK

- A. Section 05500 - Metal Fabrications

1.03 QUALITY ASSURANCE

- A. Lumber : PS 20-70.
- B. Perform work in accordance with AITC requirements and applicable building code requirements.

1.04 REFERENCE STANDARDS

- A. AITC - American Institute of Timber Construction.
- B. SFPA - Southern Forest Products Association.
- C. NFPA - National Forest Products Association. National Design Specification for Stress Grade Lumber and its Fastening.
- D. SPIB - Southern Pine Inspection Bureau - Grading Rules.
- E. FS - Federal Specifications.
- F. WWPA - Western Wood Products Association.
- G. AWPA-C1, -C2, -C18
- H. AWPB-LP-2, above ground
- I. Requirements of Local and State regulatory agencies.

1.05 DELIVERY, STORAGE AND HANDLING

- A. Store and protect products as per Division 1 requirements.
- B. Keep materials dry during delivery, handling, and storage. Do not allow contact with wet or damp surfaces. Provide air circulation within stacks.
- C. Immediately upon delivery to site inspect lumber and other products of this Section for defects and for conformance with the specified requirements. Remove defective or non-conforming materials from the site. Do not install defective or non-conforming materials.

1.06 MEASUREMENT

- A. No measurement shall be made for Rough Carpentry.

1.07 PAYMENT

- A. Payment for Rough Carpentry shall be included in the lump sum price.

2.0 PRODUCTS

2.01 MATERIALS

A. Lumber:

1. All Wood: Southern Pine (SPIB), #2 DENSE grade or better, with SPIB grade mark, kiln dried, KD- 15, pressure treated
2. All lumber (each piece) shall be grade marked and trade marked.
3. Moisture Content: Kiln dried to maximum 15%.
4. Surfacing: S4S
5. Twisted or warped lumber shall be rejected.
6. Dimensions on drawings: rough sawn unless noted as nominal.

B. Wood Treatment:

1. Treatment to be waterborne class, chromated copper arsenate (CCA) Type C 2.5 pounds per cubic foot for coastal waters, oxide formula (not salt formula). "Wolmanized" or equal.
2. Conform to FS TT-W-571, AWPB-LP-2. Mark each piece with AWPB mark.
3. Brush all field cuts with preservative used in pressure treatment.
4. Lumber redried to moisture content of 19%, marked DRY.

2.02 ACCESSORY MATERIALS

- A. Provide size, quantity and type fasteners and anchors indicated. If not indicated, provide as recommended by applicable standards and codes.
- B. Nails, Spikes, and Staples: Hot dip galvanized for exterior locations, high humidity locations, for all treated wood, for all wood above metal roof deck level, and where indicated on drawings.
- C. Bolts, Nuts, Washers, Lags, Pins, and Screws: Medium carbon steel; sized to suit application; Hot dip galvanized for all locations.
- D. Rough Hardware Standards:
 - 1. Bolts: FS FF-B575, ASTM A 687, ANSI B18.2.1, ANSI B18.2.2, ANSI B 18.5.
 - 2. Nuts: FS FF-N-836, Washers: FS FF-W-92
 - 3. Lag Screws and Bolts: FS FF-B-561, ANSI B18.2.1.
 - 4. Toggle Bolts: FS FF-B-588.
 - 5. Wood Screws: FS FF-S-111.
 - 6. Nails and staples: FS FF-N-105, SPA Standards apply for fasteners.
 - 7. Tacks: FS FF-N-103
 - 8. Expansion Shields: FS FF-S-325.
 - 9. Bar or strap anchors: ASTM A575 carbon steel.

3.0 EXECUTION

3.01 INSPECTION

- A. Examine the areas and conditions under which the Work of this Section will be performed. Correct conditions detrimental to the proper and timely completion of the Work. Do not proceed until unsatisfactory conditions have been corrected to the satisfaction of the Installer. Verify field measurements. Beginning of installation indicates acceptance of existing conditions.

3.02 WOOD TREATMENT

- A. Brush apply 3 coats of preservative treatment (to match preservative used in pressure treatment) on wood in contact with cementitious materials and roofing and related metal flashings. Apply preservative treatment in accordance with manufacturer's recommendations. Insure site-sawn ends are similarly treated. Allow preservative to cure prior to placing members.

3.03 INSTALLATION

- A. Install miscellaneous blocking, furring, cants, nailers, grounds, framing and sheathing. Coordinate with work of other Sections to allow proper attachments. Place members true to lines and levels, plumb, true, straight and square. Secure rigidly in place. Place horizontal members laid flat, crown side up.
- B. Construct members of continuous pieces of longest possible lengths. Do not splice structural members between supports.
- C. Install all metal fastenings as shown on drawings, specified, or required for proper installation.
- D. Nails, spikes, screws, bolts, and similar items shall be hot dip galvanized and of sizes and types to draw and rigidly secure members in place.
- E. Cut wood members square, closely fitted, set accurately to required lines and levels and rigidly secure in place. Do not use shims for leveling sill plates, point or grout with non shrink high strength waterproof cement for continuous solid bearing.
- F. Shim, scribe and cope carpentry to fit to other work and to existing surfaces.
- G. Verify all inserts, pipes, anchors, etc.
- H. Cut, fit and/or patch Work as required in connection with other trades which adjoin any part of this Work, leaving all Work included herein complete after other trades have completed their Work.
- I. Securely attach all carpentry work to substrates.
- J. All wood in contact with the concrete or metal deck is to be pressure treated.

3.04 TEMPORARY WORK

- A. Protect completed woodwork and other surfaces exposed to possible damage.
- B. Provide temporary stairs, ramps, runways, and ladders as required for the purpose of handling materials, personnel access to work, and temporary exits from building.

END OF SECTION

SECTION 06200

“DRIVEN PILES”

1. DESCRIPTION

This work consists of furnishing and driving treated timber piles of the type and dimensions designated on the plans, in the locations shown.

2. GENERAL

All of the work under this section shall be performed in accordance with Sections 804 and 1014 of Louisiana Standard Specifications for Roads and Bridges, latest edition, and as amended herein.

3. MEASUREMENT AND PAYMENT

Measurement and payment for timber piles will be per each timber pile installed a under Item 14 – WOODEN PILE.

Timber poles for Marine Hazard Markers are to be include in the unit bid price for Item 10 – HAZARD MARKERS.

END OF SECTION

SECTION 06300

“TREATED TIMBER”

01. DESCRIPTION

This work consists of furnishing lumber of the sizes and grade specified and of furnishing timber of the stress-grade, sizes and dimensions for the different uses specified, treated, and of preparing, framing, assembling and erecting the same, including all hardware. All timber shall be treated for coastal water environment.

02. GENERAL

Timber shall be Southern Pine and shall conform to Section 1014.01.1 of the Standard Specifications, latest edition. Treatment shall conform to Section 1014.04, coastal water conditions. Hardware, including bolts, nuts, washers, screws, nails, etc. shall conform to Sections 1013.08 and 1014.06, and shall be galvanized.

03. BASIS OF PAYMENT

There shall be no direct payment for furnishing and installing treated timber, or its associated hardware. Payment shall be made under other items.

END OF SECTION

SECTION 06400

“PIER CONSTRUCTION”

01. DESCRIPTION

This work consists of constructing the new portions of the pier as shown on the plans. The treated timber and hardware shall conform to Section 812 of the Louisiana Department of Transportation and Development Standard Specifications for Roads and Bridges, latest edition. The treated timber piles shall conform to Section 804 of the Louisiana Department of Transportation and Development Standard Specifications for Roads and Bridges, latest edition.

New galvanized hardware shall be used, conforming to Sections 1013.08 and 1014.06 of the Louisiana Department of Transportation and Development Standard Specifications for Roads and Bridges, latest edition.

02. BASIS OF PAYMENT

Payment shall be made on a per linear foot basis and shall include the cost of furnishing and installing treated timber piles, and furnishing and installing treated timber structural components, including all hardware. Payment shall be made as follows:

<u>Item No.</u>	<u>Pay Item</u>	<u>Pay Unit</u>
12	Wooden Pier	Linear Foot

END OF SECTION

SECTION 06500

SHEET PILES

1.1 SCOPE

This work consists of furnishing and installing vinyl sheet pile in accordance with the specifications as shown on the plans or directed by the Engineer.

1.2 MATERIALS

Physical properties of vinyl sheet piles shall be as defined by ASTM testing standards, The Aluminum Design Association Manual, The Naval Facilities Design Manual DM7.2, The US Army Corps of Engineers General Design Guide: PVC Sheet Pile and standard engineering practices. Physical properties shall be as follows:

PHYSICAL PROPERTIES	
Index Property	Value
Allowable Moment (M)	3,813 ft-lb/ft
Section Modulus (Z)	14.3 in ³ /ft
Moment of Inertia (I)	57 in ⁴ /ft
Impact Strength	13,750 in-lbs/in ²
Thickness (t)	0.285 in
Section Depth	8.0 in
Section Width	24 in
Material	Weatherable Rigid Vinyl

1.3 MATERIAL SOURCES

Vinyl sheet pile shall be Shoreguard SG-425 as manufactured by Crane Materials International or approved equal.

1.4 INSTALLATION

Sheet piles shall be driven with hammers adequate to drive the piles to the required depth in satisfactory condition. To maintain satisfactory alignment, sheet piles shall be driven in increments of penetration necessary to prevent distortion, twisting out of position or pulling apart at interlocks. Use of a vibratory hammer or jets will not be allowed unless otherwise approved by the Engineer.

1.5 ACCEPTANCE

Steel Sheet Piles shall be accepted once they have been driven to the minimum sheeting tip elevation specified on the Plans. Square footage of sheeting driven beyond the minimum sheeting tip elevation will not be accepted for payment.

1.6 MEASUREMENT AND PAYMENT

Payment for this item will be made at the contract unit price per square foot in-place. Price and payment shall constitute full compensation for furnishing all labor, materials, and equipment for construction and maintenance of all required sheet piles and performing all work specified herein. No payment shall be made for Sheet Piling that are rejected or damaged due to fault or negligence by the Contractor.

END OF SECTION

SECTION 06610

FIBERGLASS REINFORCED PLASTICS (FRP) FABRICATIONS

MOLDED MESH GRATING

PART 1 - GENERAL

1.1 SCOPE OF WORK

- A. The CONTRACTOR shall furnish, fabricate (where necessary), and install all fiberglass reinforced plastic (FRP) items, with all appurtenances, accessories and incidentals necessary to produce a complete, operable and serviceable installation as shown on the Contract Drawings and as specified herein, and in accordance with the requirements of the Contract Documents.

1.2 REFERENCES

- A. The publications listed below (latest revision applicable) form a part of this specification to the extent referenced herein. The publications are referred to within the text by the designation only.

AMERICAN SOCIETY FOR TESTING AND MATERIALS (ASTM) Test Methods:

ASTM D 635 Rate of Burning and/or Extent and Time of Burning of Self-Supporting Plastics in a Horizontal Position

ASTM E 84 Surface Burning Characteristics of Building Materials

1.3 CONTRACTOR SUBMITTALS

- A. The CONTRACTOR shall furnish shop drawings of all fabricated gratings and accessories in accordance with the provisions of this Section.
- B. The CONTRACTOR shall furnish manufacturer's shop drawings clearly showing material sizes, types, styles, part or catalog numbers, complete details for the fabrication and erection of components including, but not limited to, location, lengths, type and sizes of fasteners, clip angles, member sizes, and connection details.
- C. The CONTRACTOR shall submit the manufacturer's published literature including structural design data, structural properties data, grating load/deflection tables, corrosion resistance tables, certificates of compliance, test reports as applicable, concrete anchor systems and their allowable load tables, and design calculations for

systems not sized or designed in the contract documents.

- D. The CONTRACTOR may be requested to submit sample pieces of each item specified herein for acceptance by the ENGINEER as to quality and color. Sample pieces shall be manufactured by the method to be used in the WORK.

1.4 QUALITY ASSURANCE

- A. All items to be provided under this Section shall be furnished only by manufacturers having a minimum of ten (10) years experience in the design and manufacture of similar products and systems. Additionally, if requested, a record of at least five (5) previous, separate, similar successful installations in the last five (5) years shall be provided.
- B. Manufacturer shall offer a 3 year limited warranty on all FRP products against defects in materials and workmanship.
- C. Manufacturer shall be certified to the ISO 9001-2008 standard.
- D. Manufacturer shall provide proof of certification from at least two other quality assurance programs for its facilities or products (DNV, ABS, USCG, AARR).

1.5 PRODUCT DELIVERY AND STORAGE

- A. Delivery of Materials: Manufactured materials shall be delivered in original, unbroken pallets, packages, containers, or bundles bearing the label of the manufacturer. Adhesives, resins and their catalysts and hardeners shall be crated or boxed separately and noted as such to facilitate their movement to a dry indoor storage facility.
- B. Storage of Products: All materials shall be carefully handled to prevent them from abrasion, cracking, chipping, twisting, other deformations, and other types of damage. Adhesives, resins and their catalysts are to be stored in dry indoor storage facilities between 70 and 85 degrees Fahrenheit (21 to 29 degrees Celsius) until they are required.

PART 2 - PRODUCTS

2.1 MANUFACTURER

- A. Access Floor Grating shall be Micro-Mesh[®] as manufactured by:

Fibergrate Composite Structures Inc.
5151 Belt Line Road, Suite 1212
Dallas, Texas 75254-7028 USA

(800) 527-4043 Phone (972) 250-1530 Fax

Website: www.fibergrate.com

E-mail: info@fibergrate.com

Or approved equal.

2.2 GENERAL

- A. All FRP items furnished under this Section shall be composed of fiberglass reinforcement and resin in qualities, quantities, properties, arrangements and dimensions as necessary to meet the design requirements and dimensions as specified in the Contract Documents.
- B. Fiberglass reinforcement shall be continuous roving in sufficient quantities as needed by the application and/or physical properties required.
- C. Resin shall be Polyester, with chemical formulations as necessary to provide the corrosion resistance, strength and other physical properties as required.
- D. All finished surfaces of FRP items and fabrications shall be smooth, resin-rich, free of voids and without dry spots, cracks, crazes or unreinforced areas. All glass fibers shall be well covered with resin to protect against their exposure due to wear or weathering.
- E. All grating products shall have a tested flame spread rating of 25 or less per ASTM E-84 Tunnel Test. Gratings shall not burn past the 25 mm reference mark and will be classified HB per ASTM D635.
- F. All mechanical grating clips shall be manufactured of Type 316SS (stainless steel).

2.3 MOLDED FRP GRATING

- A. Manufacture: Grating shall be of a one piece molded construction with tops and bottoms of bearing bars and cross bars in the same plane. Grating shall have a square mesh pattern providing bidirectional strength. Grating shall be reinforced with continuous rovings of equal number of layers in each direction. The top layer of reinforcement shall be no more than 1/8" below the top surface of the grating so as to provide maximum stiffness and prevent resin chipping of unreinforced surfaces. Percentage of glass (by weight) shall not exceed 35% so as to achieve maximum corrosion resistance, and as required to maintain the structural requirements of the CONTRACT.

After molding, no dry glass fibers shall be visible on any surface of bearing bars or cross bars. All bars shall be smooth and uniform with no evidence of fiber orientation

irregularities, interlaminar voids, porosity, resin rich or resin starved areas.

- B. Non-slip surfacing: Grating shall be manufactured with a grit top surface.
- C. Bar intersections of full depth bars are to be filleted to a minimum radius of 1/16" to eliminate local stress concentrations and the possibility of resin cracking at these locations. Intersections of secondary, partial depth bars do not require a fillet.
- D. Fire rating: Grating shall be fire retardant with a tested flame spread rating of 25 or less when tested in accordance with ASTM E 84. Certifications shall be dated within the past two years and test data performed only on the resin shall not be acceptable.
- E. Resin system: The resin system used in the manufacture of the grating shall be Corvex[®]. Manufacturer may be required to submit corrosion data from tests performed on actual grating products in standard chemical environments. Corrosion resistance data of the base resin from the manufacturer is not a true indicator of grating product corrosion resistance and shall not be accepted.
- F. Color: Light Gray
- G. Depth: 1-1/2" with a tolerance of plus or minus 1/16".
- H. Mesh Configuration: 1-1/2" square mesh bottom, 3/4" square mesh top, with a tolerance of plus or minus 1/16" mesh centerline to centerline. Top surface meets ADA requirements. Panels shall be 2'0" x 2'0" square.
- I. Load/Deflection: Load capacity and deflection data was developed using the Recommended Test Procedures for Access Floors by the Ceilings & Interior Systems Construction Association (CISCA). Setup requires that the panels ". . . shall be supported on an understructure support identical to that utilized in an installed system." Load criteria reflect a Case 1 condition defined as "Concentrated loading at the center of the panel (centroid) with panel supported at four (4) corners."

A load of 500 pounds with concentrated loading at the center of the panel (Case 1 centroid) will produce a deflection of 0.07".
- J. Substitutions: Other products of equal strength, stiffness, corrosion resistance and overall quality may be submitted with the proper supporting data to the engineer for approval.

2.4 GRATING FABRICATION

- A. Measurements: Grating supplied shall meet the dimensional requirements and tolerances as shown or specified. The Contractor shall provide and/or verify measurements in field for work fabricated to fit field conditions as required by grating manufacturer to complete the work. When field dimensions are not required,

contractor shall determine correct size and locations of required holes or cutouts from field dimensions before grating fabrication.

- B. Layout: Each grating section shall be readily removable, except where indicated on drawings. Manufacturer to provide openings and holes where located on the contract drawings. Grating openings which fit around protrusions (pipes, cables, machinery, etc.) shall be discontinuous at approximately the centerline of opening so each section of grating is readily removable.
- C. Sealing: All shop fabricated grating cuts shall be coated with vinyl ester resin to provide maximum corrosion resistance. All field fabricated grating cuts shall be coated similarly by the contractor in accordance with the manufacturer's instructions.
- D. Hardware: Type 316 stainless steel hold-down clips shall be provided and spaced at maximum of four feet apart with a minimum of four per piece of grating, or as recommended by the manufacturer.

PART 3 - EXECUTION

3.1 INSPECTION

- A. Shop inspection is authorized as required by the Engineer and shall be at Contractor's expense. The fabricator shall give ample notice to Contractor prior to the beginning of any fabrication work so that inspection may be provided. The grating shall be as free, as commercially possible, from visual defects such as foreign inclusions, delamination, blisters, resin burns, air bubbles and pits. The surface shall have a smooth finish (except for grit top surfaces).

3.2 INSTALLATION

- A. Contractor shall install gratings in accordance with manufacturer's assembly drawings. Panels are to be supported with grating legs in each corner or other equivalent support mechanism. Lock grating panels securely in place with hold-down fasteners or as specified herein. Field cut and drill fiberglass reinforced plastic products with carbide or diamond tipped bits and blades. Seal cut or drilled surfaces in accordance with manufacturer's instructions. Follow manufacturer's instructions when cutting or drilling fiberglass products or using resin products; provide adequate ventilation.

END OF SECTION



SECTION 13
DEPARTMENT OF THE ARMY
U.S. ARMY CORPS OF ENGINEERS, NEW ORLEANS DISTRICT
7400 LEAKE AVE
NEW ORLEANS, LA 70118-3651

October 19, 2023

Regulatory Division
Eastern Evaluation Branch

SUBJECT: MVN-2016-00731-EPP

St. Tammany Parish Government
21454 Koop Drive
Mandeville, Louisiana 70434

Dear Ms. O'Dell:

The proposed work, to dredge and install and maintain a bulkhead, breakwater and pier, located near the Tchefuncte River Lighthouse, at Lake Pontchartrain and the Tchefuncte River, in St. Tammy Parish, Louisiana, as shown on the enclosed drawings, is authorized under **Category II** of the **Programmatic General Permit**, from the District Engineer at New Orleans, Louisiana, provided that all conditions of the permit are met. In addition, the following special conditions are made part of this authorization:

1. Permittee must comply with the enclosed: "STANDARD MANATEE CONDITIONS FOR IN-WATER ACTIVITIES".
2. The permittee has been made aware and shall adhere to all state statutes (R.S. 56:2011 et seq.) and department regulations (LAC 76:XIII.101 et seq.) concerning dredging of fill sand and fill material from water bottoms of the state of Louisiana and severance royalties. For more information, contact Mr. Dave Butler, with the Louisiana Department of Wildlife and Fisheries, at 504-286-4173.
3. Permittees that discover any previously unknown historic, cultural, or archeological remains and artifacts while accomplishing the permitted activity must immediately notify the U.S. Army Corps of Engineers New Orleans District Regulatory Division (CEMVN-RG), halt all construction activity at the location of discovery, and avoid construction activities within a fifty (50) foot buffer zone of the location of discovery until the required coordination has been completed. CEMVN-RG will initiate the Federal, Tribal, and state coordination required to determine if the items or remains warrant a recovery effort or if the site is eligible for listing in the National Register of Historic Places.
4. If abandoned cemeteries, unmarked graves, or human remains are discovered during the permitted activity, the permittee will stop work immediately and comply with the Louisiana Unmarked Human Burial Sites Preservation Act (La. R.S. 8:671 et seq.). The permittee will notify local law enforcement, CEMVN-RG, and the Louisiana Division of Archaeology (LDOA), within the Louisiana Department

of Culture, Recreation and Tourism, Office of Cultural Development, by telephone at 225-342-8170 to assess the nature and age of the human skeletal remains within twenty-four (24) hours of the discovery of unmarked human remains and will accompany local law enforcement personnel during all field investigations. If the appropriate local law enforcement official determines that the remains are not a crime scene, and the remains are more than 50 years old, LDOA has jurisdiction over the remains. In no instance will human remains be removed from the discovery site until jurisdiction is established. In cases where the LDOA assumes jurisdiction and the remains are determined to be American Indian, LDOA will consult with Tribes, CEMVN-RG, and the permittee to determine the appropriate course of action.

5. The permittee has been made aware and shall adhere to the developed Vibration Monitoring Plan. All responsibilities and compliance related to the subject conditions are hereby directed to and have oversight by the USACE Planning Division Archaeologist and/or Tribal Liaison (PDS-N), Noah Fulmer, with this District. Should you have any questions, you shall contact, Noah Fulmer at 504-862-1983, or by email at noah.j.fulmer@usace.army.mil.

- a. Documentation of the condition of the historic structure prior to commencement of adjacent work, including a detailed photo survey of existing damage/condition;

- b. Establishment of vibration limits not to be exceeded based on condition of the resource, founding soil conditions, and type of construction vibration;

- c. Implementation of vibration mitigating measures on the construction site and/or at the historic structure, which could include specific means and methods or protective measures;

- d. Vibration monitoring during construction (use of accelerometers, seismometers and/or inclinometers) and visual inspection by trained field personnel;

- e. Regular condition surveys and reviews during construction to identify damage, to evaluate the efficacy of protective measures already in place, and to identify and implement additional corrective steps; and

- f. Will provide for a final summary report of vibration monitoring effort to document the implementation of the permit condition.

This authorization has a blanket water quality certification from the Louisiana Department of Environmental Quality; therefore, no additional authorization from DEQ is required.

However, prior to commencing work on your project, you must obtain approvals from state and local agencies as required by law and by terms of this permit. These approvals include, but are not limited to, a permit, consistency determination or determination of “no direct or significant impact (NDSI) on coastal waters” from the Louisiana Department of Natural Resources, Office of Coastal Management. This approval to perform work is valid for 5 years from the date of this letter.

Permittee is aware that this office may reevaluate its decision on this permit at any time the circumstances warrant.

If you should have any questions, you may contact Stephanie Castaing at (504) 862-1564 or Stephanie.L.Castaing@usace.army.mil.

Sincerely,

FOR Martin S. Mayer
Chief, Regulatory Division

Enclosures

cc: Digital Engineering



**DEPARTMENT OF NATURAL RESOURCES
OFFICE OF COASTAL MANAGEMENT**

P.O. BOX 44487
BATON ROUGE, LOUISIANA 70804-4487
(225)342-7591
1-800-267-4019

COASTAL USE PERMIT/CONSISTENCY DETERMINATION

C.U.P. No.: P20210496

C.O.E. No.:

NAME: **ST. TAMMANY PARISH GOVERNMENT**
c/o DIGITAL ENGINEERING
527 W. ESPLANADE AVE., SUITE 200
KENNER, LA 70065
Attn: Andrew Woodroof

LOCATION: **Saint Tammany Parish, LA**
Lat 30-22-36 N / Long. 90-10-09 W; Lake Ponchartrain; Town of Madisonville, 70447.

DESCRIPTION: Proposed construction of a new breakwater and bulkhead to serve the existing Tchefuncte River Lighthouse. In addition, a new pier will be constructed to allow for boat access to lighthouse. Approximately 820 cy of waterbottoms will be excavated for a proposed floatation channel and placed between the proposed bulkhead and shoreline. Approximately 3,630 cy of riprap/stone material will be hauled in and placed on site.

In accordance with the rules and regulations of the Louisiana Coastal Resources Program and Louisiana R.S. 49, Sections 214.21 to 214.41, the State and Local Coastal Resources Management Act of 1978, as amended, the permittee agrees to:

1. Carry out, perform, and/or operate the use in accordance with the permit conditions, plans and specifications approved by the Department of Natural Resources.
2. Comply with any permit conditions imposed by the Department of Natural Resources.
3. Adjust, alter or remove any structure or other physical evidence of the permitted use if, in the opinion of the Department of Natural Resources, it proves to be beyond the scope of the use as approved or is abandoned.
4. Provide, if required by the Department of Natural Resources, an acceptable surety bond in an appropriate amount to ensure adjustment, alteration, or removal should the Department of Natural Resources determine it necessary.
5. Hold and save the State of Louisiana, the local government, the department, and their officers and employees harmless from any damage to persons or property which might result from the use, including the work, activity, or structure permitted.
6. Certify that the use has been completed in an acceptable and satisfactory manner and in accordance with the plans and specifications approved by the Department of Natural Resources. The Department of Natural Resources may, when appropriate, require such certification to be given by a registered professional engineer.
7. All terms of the permit shall be subject to all applicable federal and state laws and regulations.
8. This permit, or a copy thereof, shall be available for inspection at the site of work at all times during operations.
9. The applicant will notify the Office of Coastal Management of the date on which initiation of the permitted activity described under the "Coastal Use Description" began. The applicant shall notify the Office of Coastal Management by entering a commencement date through the online system, or by mailing said information to OCM.
10. Unless specified elsewhere in this permit, this permit authorizes the initiation of the coastal use described under "Coastal Use Description" for two (2) years from the date of the signature of the Secretary or his designee on the original permit which was July 12, 2023. If the coastal use is not initiated within this two (2) year period, then this permit will expire and the applicant will be required to submit a new application. Initiation of the coastal use, for the purposes of this permit, means the actual physical beginning of the use of activity for which the permit is required. Initiation does not include preparatory activities, such as movement of equipment onto the coastal use site, expenditure of funds, contracting out of work, or performing activities which by themselves do not require a permit. In addition, the permittee must, in good faith, and with due diligence, reasonably progress toward completion of the project once the coastal use has been initiated.
11. The following special conditions must also be met in order for the use to meet the guidelines of the Coastal Resources Program:
 - a. Structures must be marked/lighted in accordance with U. S. Coast Guard regulations.
 - b. This permit does not convey any property rights, mineral rights, or exclusive privileges; nor does it authorize injury to property.
 - c. All structures built under the authorization and conditions of this permit shall be removed from the site within 120 days



of abandonment of the facilities for the herein permitted use, or when these structures fall into a state of disrepair such that they can no longer function as intended. This condition does not preclude the necessity for revising the current permit or obtaining a separate Coastal Use Permit, should one be required, for such removal activities.

- d. Permittee shall submit to, and have approved by, St. Tammany Parish Government, an engineered fill plan prior to commencement of any bulkheading, grading, filling, or construction of any nature. Changes to the project design as a result of the requirement of St. Tammany Parish Government approval must be resubmitted to OCM for consideration of revision of this permit.
- e. All fill material shall be clean and free of contaminants and shall not contain hazardous materials such as asbestos or asbestos residue, shingles, tires, oil/grease residue, exposed rebar, protruding objects, etc.
- f. All logs, stumps and other debris encountered during dredging activities shall be removed from the site during or immediately after the activity and disposed of in accordance with all applicable laws and regulations.
- g. That a Class D permit is received from the Division of Administration, State Land Office prior to the initiation of construction.
- h. Permittee shall obtain a Cooperative Endeavor Agreement from the Division of Administration, State Land Office prior to initiation of any construction activities.
- i. Wildlife Diversity Program:
The database indicates that the West Indian Manatee (*Trichechus manatus*) may occur in the surrounding waterbodies of the project footprint. The manatee is a large mammal that inhabits both fresh and salt water. Although the manatee is a year round resident of Florida and Central America, the species has been known to migrate to areas along the Atlantic and Gulf coasts during the summer months. The West Indian Manatee is a threatened species protected under the Endangered Species Act of 1973 and the Federal Marine Mammal Protection Act of 1972. In Louisiana, take or harassment of a manatee is a violation of state and federal laws. Critical habitat for the manatee includes beds of submerged aquatic vegetation (e.g., sea-grass beds). Areas with sea-grass beds should be avoided during project activities. Report all manatee sightings to the Louisiana Department of Wildlife and Fisheries at 504-286-4052 or 1-800-442-2511.

No other impacts to rare, threatened or endangered species or critical habitats are anticipated from the proposed project. No state or federal parks, wildlife refuges, wildlife management areas or scenic rivers are known at the specified site or within ¼ mile of the proposed project. The Wildlife Diversity Program (WDP) reports summarize the existing information known at the time of the request regarding the location in question. WDP reports should not be considered final statements on the biological elements or areas being considered, nor should they be substituted for on-site surveys required for environmental assessments. If at any time WDP tracked species are encountered within the project area, please contact our biologist at 225-763-3554.

- j. The permittee shall ensure that all sanitary sewage and/or related domestic wastes generated during the subject project activity and at the site, thereafter, as may become necessary shall not be discharged into any of the streams or adjacent waters of the area without authorization from DH and/or DEQ or, in the case of total containment, shall be disposed of in approved sewerage and sewage treatment facilities, as is required by the State Sanitary Code and DEQ regulations. Such opinion as may be served by those comments offered herein shall not be construed to suffice as any more formal approval(s) which may be required of possible sanitary details (i.e. provisions) scheduled to be associated with the subject activity. Such shall generally require that appropriate plans and specifications be submitted to DH for purpose of review and approval prior to any utilization of such provisions.



- k. Permittee is subject to all applicable state laws related to damages which are demonstrated to have been caused by this action.
- l. Permittee shall allow representatives of the Office of Coastal Management or authorized agents to make periodic, unannounced inspections to assure the activity being performed is in accordance with the conditions of this permit.
- m. Permittee shall comply with all applicable state laws regarding the need to contact the Louisiana One Call (LOC) system (1-800-272-3020) to locate any buried cables and pipelines.
- n. This permit authorizes the initiation of the Coastal Use described under "Coastal Use Description" for two (2) years from the date of the signature of the Secretary or his designee on the original permit which was July 12, 2023. Initiation of the Coastal Use, for purposes of this permit, means the actual physical beginning of the use or activity for which the permit is required. Initiation does not include preparatory activities, such as movement of equipment onto the Coastal Use site, expenditure of funds, contracting out of work, or performing activities which by themselves do not require a permit. In addition, Permittee must, in good faith and with due diligence, reasonably progress toward completion of the project once the Coastal Use has been initiated. If the Coastal Use is not initiated within this two (2) year period, an extension may be granted pursuant to the requirements contained in the Rules and Procedures for Coastal Use Permits (Title 43:1.723.D.). Please note that a request for permit extension MUST be made no sooner than one hundred eighty (180) days and no later than sixty (60) days prior to the expiration of the permit.

The expiration date of this permit is five (5) years from the date of the signature of the Secretary or his designee on the original permit which was July 12, 2023. If the Coastal Use is not completed within this five (5) year period, an extension may be granted pursuant to the requirements contained in the Rules and Procedures for Coastal Use Permits (LAC 43:1.723(D)).

Upon expiration of this permit, a new Coastal Use Permit will be required for completion of any unfinished or uncommenced work items and for any maintenance activities involving dredging or fill that may become necessary. Other types of maintenance activities may also require a new Coastal Use Permit.

- o. This determination does not eliminate the need to obtain a permit from the United States Army, Corps of Engineers or any other Federal, state or local approval that may be required by law. The drawings submitted with your referenced application are attached hereto and made a part of the record.

***** End of Conditions *****

By accepting this permit the applicant agrees to its terms and conditions.

I affix my signature and issue this permit this 12th day of July, 2023.

THE DEPARTMENT OF NATURAL RESOURCES

A handwritten signature in black ink, appearing to read "Kyle F. Balkum".

Kyle F. Balkum, Administrator
Office of Coastal Management

This agreement becomes binding when signed by Administrator of the Office of Coastal Management Permits/Mitigation Division, Department of Natural Resources.

Attachments



Final Plats:

1) P20210496 Final Plats 07/02/2021

cc: Martin Mayer, COE w/attachments
Dave Butler, LDWF w/attachments
St. Tammany Levee, Drainage and Conservation District, LD w/attachments
Les Rosso, State Land w/attachments
Jordan Cobbs, OCM w/attachments
Samuel Welty, OCM/FI w/attachments
Saint Tammany Parish w/attachments

ST. TAMMANY PARISH GOVERNMENT w/attachments

PARISH OF ST. TAMMANY

DEPARTMENT OF ENGINEERING

TCHEFUNCTE HABITAT RESTORATION

PROJECT NO. DV20000135

ST. TAMMANY PARISH, LOUISIANA



INDEX TO SHEETS

SHEET NO.	DESCRIPTION OF SHEETS
1	TITLE SHEET
2	GENERAL NOTES
3	SUMMARY OF QUANTITIES
4	OVERALL SITE PLAN
5	BREAKWATER DETAILS
6	PIER PLAN, SECTIONS, & DETAILS
7	PIER SECTIONS & DETAILS
8	PIER AND BREAKWATER PROFILE
9	BULKHEAD SECTIONS & DETAILS
10	CROSS SECTIONS
11	CROSS SECTIONS
12	MARINE HAZARD MARKER DETAILS
13	TURBIDITY CURTAIN DETAILS
14	SURVEY



LAYOUT MAP

SCALE: 1 INCH = 300 FEET

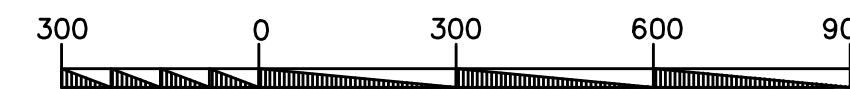

MML BOARD OF DIRECTORS - EXECUTIVE COMMITTEE

- | | |
|-------------------|--------------------|
| ALEXIS HOCEVAR | PRESIDENT |
| JOHN GNIADY | PAST PRESIDENT |
| JIM MACPHERSON | EXECUTIVE DIRECTOR |
| STEVEN MARCUS | VICE PRESIDENT |
| TOM MEEHAN | SECRETARY |
| MICHAEL GAGLIARDI | TREASURER |

MICHAEL COOPER PARISH PRESIDENT

PARISH COUNCIL

- | | |
|------------------|---------------------|
| RICK SMITH | COUNCIL DISTRICT 1 |
| LARRY ROLLING | COUNCIL DISTRICT 2 |
| MARTHA CAZAUBON | COUNCIL DISTRICT 3 |
| KATHY SEIDEN | COUNCIL DISTRICT 4 |
| PAT PHILLIPS | COUNCIL DISTRICT 5 |
| CHERYL TANNER | COUNCIL DISTRICT 6 |
| JOE IMPASTO | COUNCIL DISTRICT 7 |
| PAT BURKE | COUNCIL DISTRICT 8 |
| DAVID COUGLE | COUNCIL DISTRICT 9 |
| MAUREEN O'BRIEN | COUNCIL DISTRICT 10 |
| AUTHUR LAUGHLIN | COUNCIL DISTRICT 11 |
| JERRY BINDER | COUNCIL DISTRICT 12 |
| JEFF CORBIN | COUNCIL DISTRICT 13 |
| JIMMY STRICKLAND | COUNCIL DISTRICT 14 |

PREPARED BY AND RECOMMENDED FOR APPROVAL BY:



Andrew Woodroof
ANDREW WOODROOF, P.E.
 DIGITAL ENGINEERING & IMAGING INC.
 DATE: 5-20-2024

TYPE OF CONSTRUCTION:

- ROCK BREAKWATER CONSTRUCTION
- PIER CONSTRUCTION
- BULKHEAD CONSTRUCTION
- FLOTATION CHANNEL DREDGING



527 W. ESPLANADE AVE., SUITE 200 - KENNER, LA 70065 - PH. (504) 468-6129

SUMMARY OF ESTIMATED QUANTITIES

Ref No.	Item Description	Quantity	Unit
Base Bid - Shoreline Protection			
1	Mobilization and Demobilization	1	LS
2	Vinyl Sheetpile	6,000	SF
3	Geotextile	600	SY
4	Geogrid	600	SY
5	Dredging, Fill, and Grading	1	LS
6	Rip-Rap R200	500	TON
7	Pile Removal	50	EA
Alternate 1 - Breakwater			
8	Mobilization and Demobilization	1	LS
9	Geotextile	3,500	SY
10	Geogrid	3,500	SY
11	#57 Stone (Net Section)	1,750	TON
12	Rip-Rap R650	2,600	TON
13	Rip-Rap R1500	2,600	TON
14	Marine Hazard Markers	3	EA
Alternate 2 - Pier			
15	Mobilization and Demobilization	1	LS
16	Wooden Pier with Composite Deck	310	LF
17	Pier Landing Stairs with Concrete Pad	1	LS
18	Wooden Pile	51	EA

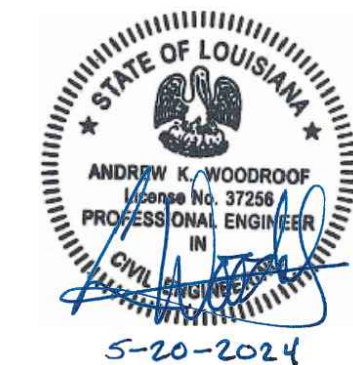

 527 W. ESPLANADE AVE., STE. 200 - KENNER, LA. 70065 - PH. (504) 488-6129 DESIGNED BY: ANW DRAWN BY: LAC PROJECT MGR: ANW CHECKED BY: RJD APPROVED BY: ANW	TCHEFUNCTE HABITAT RESTORATION ST. TAMMANY PARISH, LOUISIANA SUMMARY OF QUANTITIES
PROJECT NO. DV20000135	DATE MAY 2024
SCALE SHEET NO. 3	
REVISION DATE DESCRIPTION	BY

- NOTE:
- STONE SHALL BE PLACED IN 3 FOOT LIFTS UNTIL THE STONE REACHES ABOVE THE WATER SURFACE. STONE PLACED ABOVE THE WATER SURFACE SHOULD BE PLACED IN 2 FOOT LIFTS.
 - GEOTEXTILE SHALL BE SEWN DIRECTLY TO THE GEOGRID. COMPOSITE PRODUCT SHALL BE SET WITH GEOGRID SIDE UP AND 6" OF CLASS 57 STONE PLACED ON TOP OF GEOGRID.
 - BREAKWATER HEAD CREST WIDTH VARIES BETWEEN STA. 3+00 AND END OF BREAKWATER. MAXIMUM WIDTH OF 11' OCCURS AT STA. 1+75.

**BREAKWATER
CONSTRUCTION
SECTION B-B
LOOKING SOUTH**

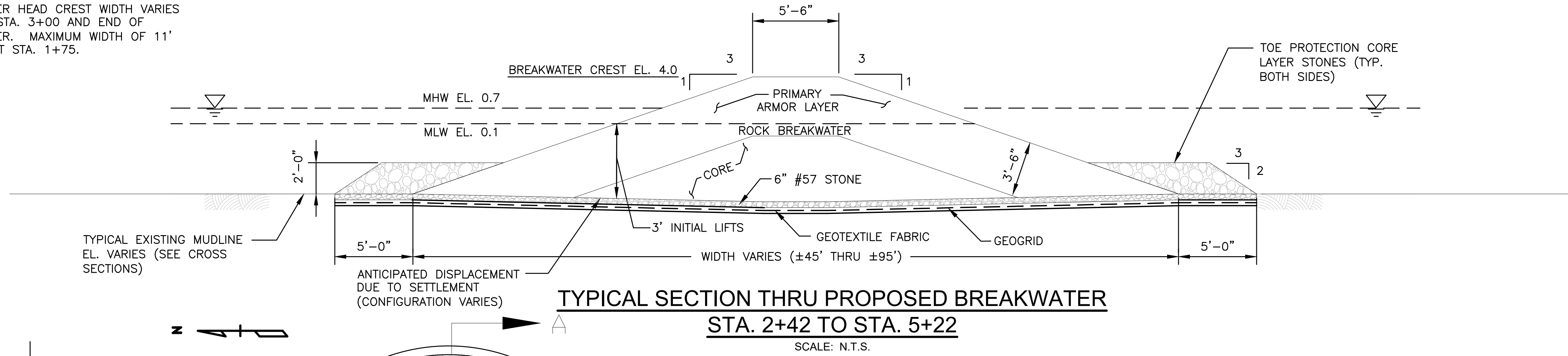

PRIMARY ARMOR LAYER RIP-RAP GRADATION

PERCENT LIGHTER BY WEIGHT (POUNDS)	GRADATION LIMITS INDIVIDUAL STONE WEIGHT (POUNDS)	
	UPPER LIMIT	LOWER LIMIT
100	1500	600
50	650	300
15	330	100

CORE LAYER RIP-RAP GRADATION

PERCENT LIGHTER BY WEIGHT (POUNDS)	GRADATION LIMITS INDIVIDUAL STONE WEIGHT (POUNDS)	
	UPPER LIMIT	LOWER LIMIT
100	650	260
50	280	130
15	130	40

**BREAKWATER
CONSTRUCTION
SECTION A-A
LOOKING SOUTH**

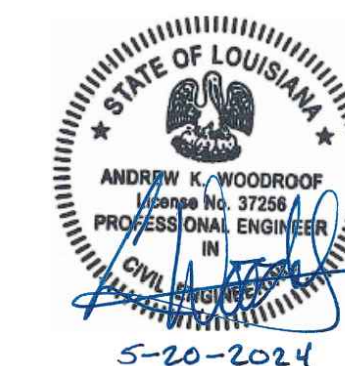
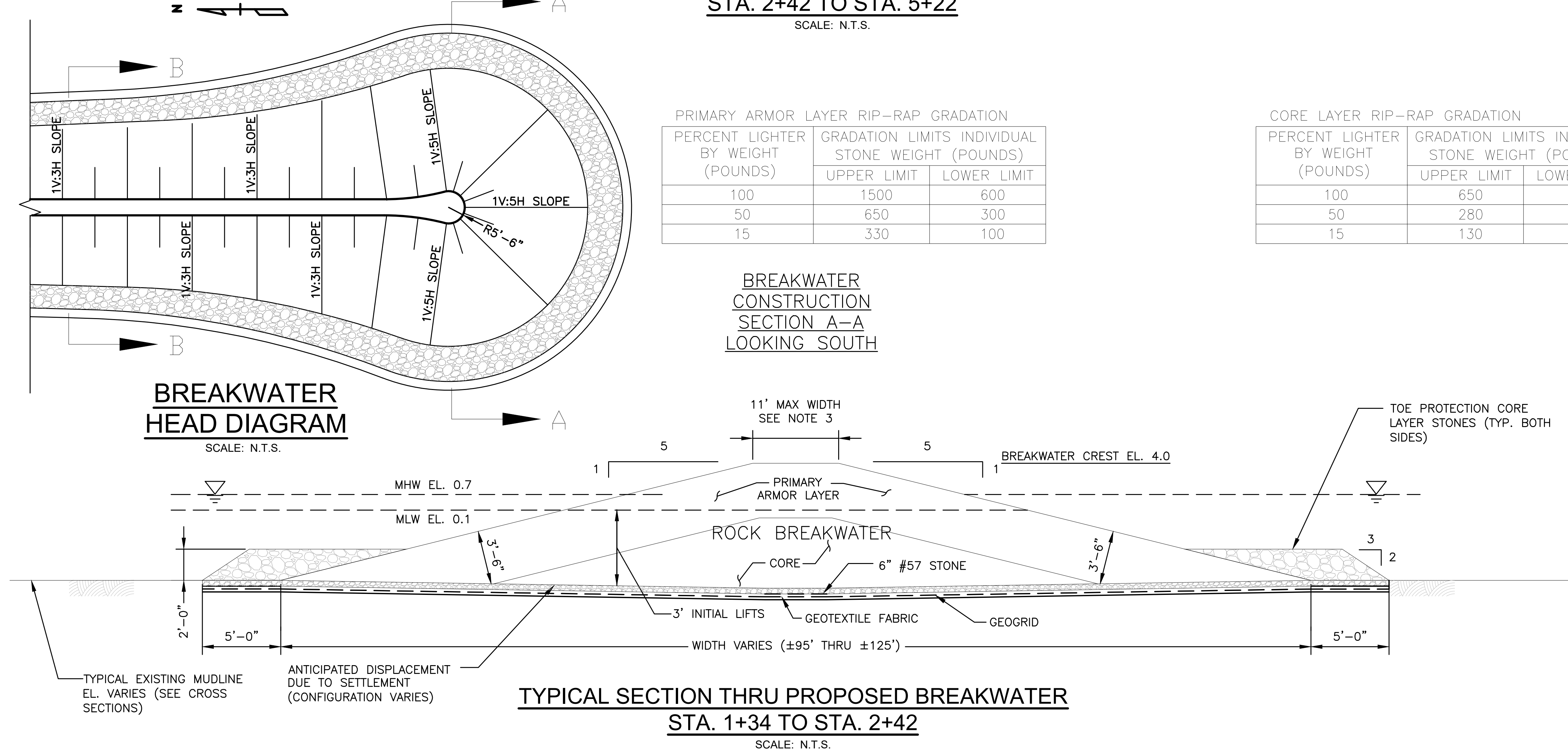

TCHEFUNCTE HABITAT RESTORATION
ST. TAMMANY PARISH, LOUISIANA
BREAKWATER DETAILS

PROJECT NO. DV20000135
DATE MAY 2024
SCALE NOT TO SCALE
SHEET NO. 5

REVISION	DATE	DESCRIPTION	BY

DWG PATH: S:\640 Maritime Museum\640-001\DWGS\ LAYOUT TAB: 6
 DWG NAME: _06-07_Pier Details
 PLOT DATE: Monday, May 20, 2024 @ 8:10am

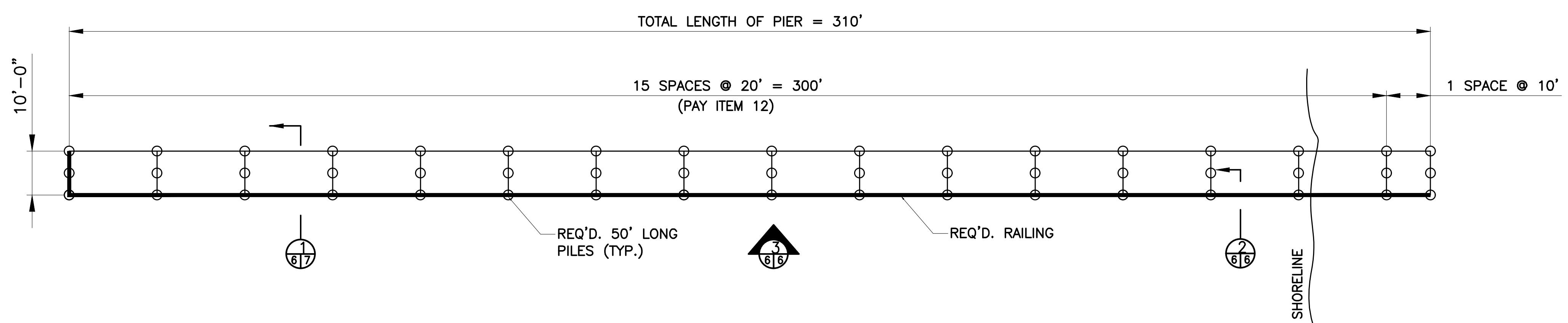

PLAN

SCALE: 1" = 20'-0"

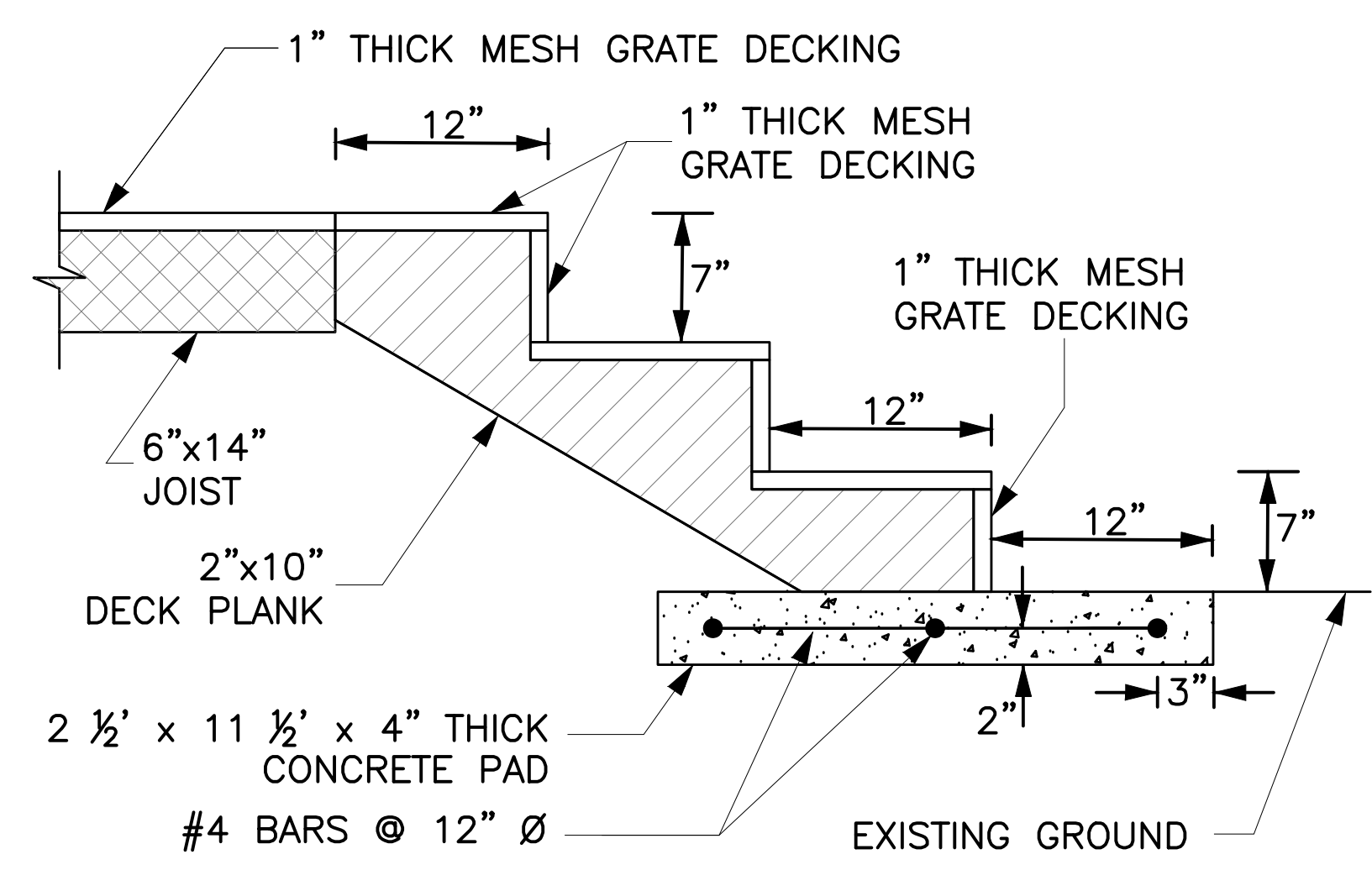

STAIRCASE DETAIL

N.T.S.

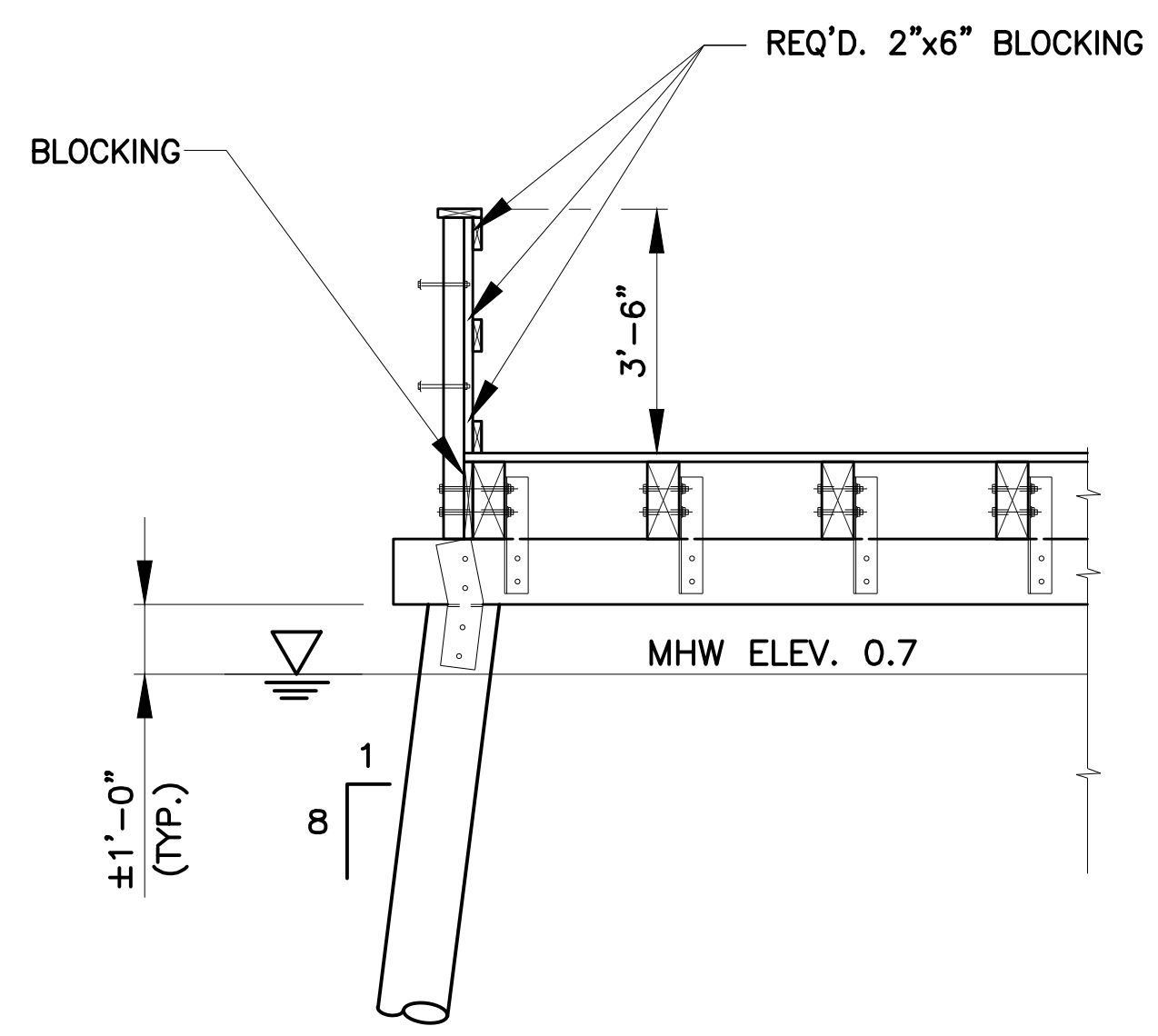

**SIDE PIER SECTION
LOOKING SOUTH**

N.T.S.

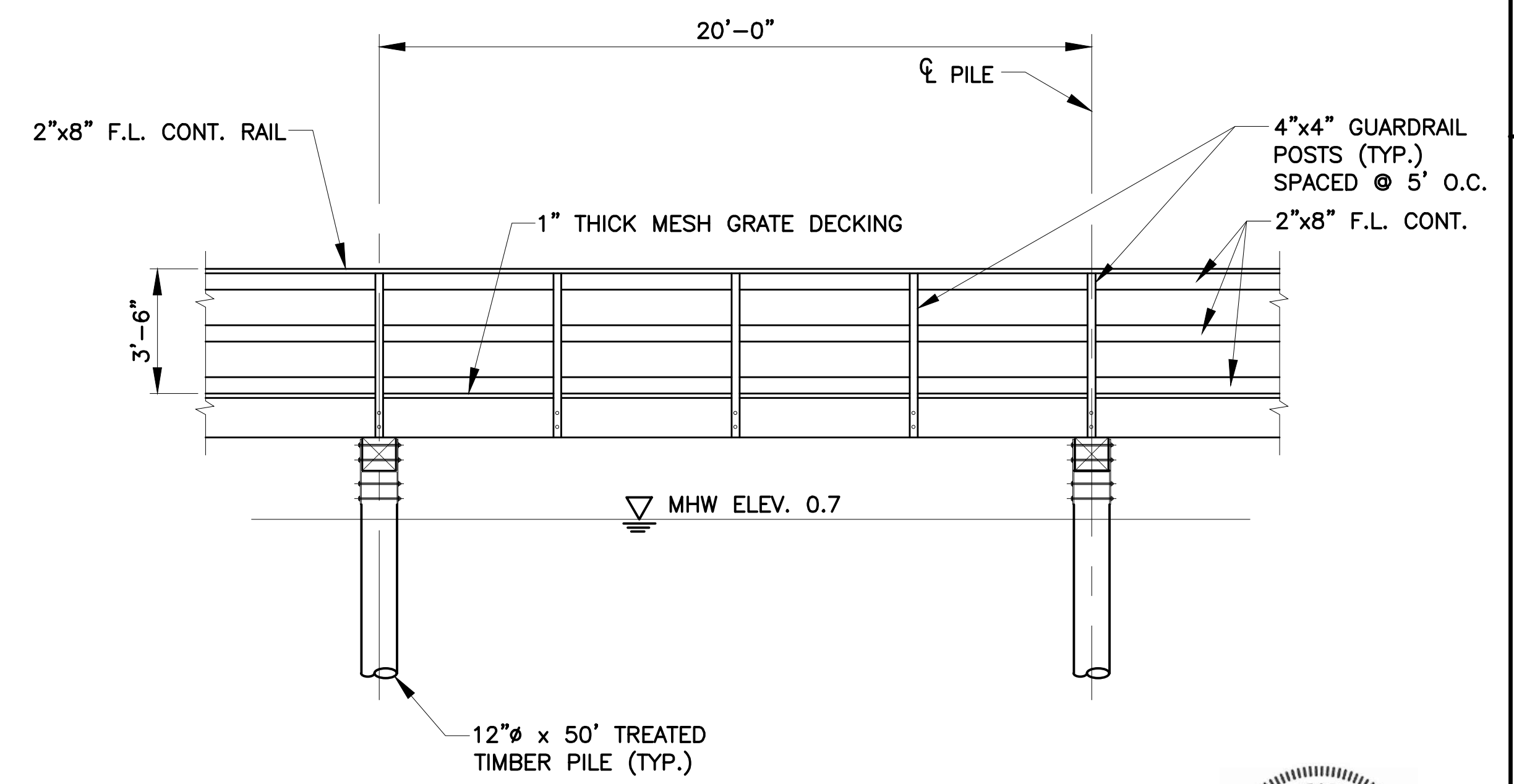

**LONGITUDINAL SECTION
LOOKING WEST**

N.T.S.



		PROJECT NO. DV20000135 DATE MAY 2024 SCALE AS SHOWN SHEET NO. 6
TCHEFUNCTE HABITAT RESTORATION ST. TAMMANY PARISH, LOUISIANA		PROJECT MGR.: ANW DRAWN BY: LAC CHECKED BY: ANW APPROVED BY: RJD
PIER PLAN, SECTIONS, & DETAILS		DESCRIPTION DATE REVISION

DWG PATH: s:\640 Maritime Museum\640-001\DWGS\ DWG NAME: _08_CrossSection PLOT DATE: Monday, May 20, 2024 8:10am

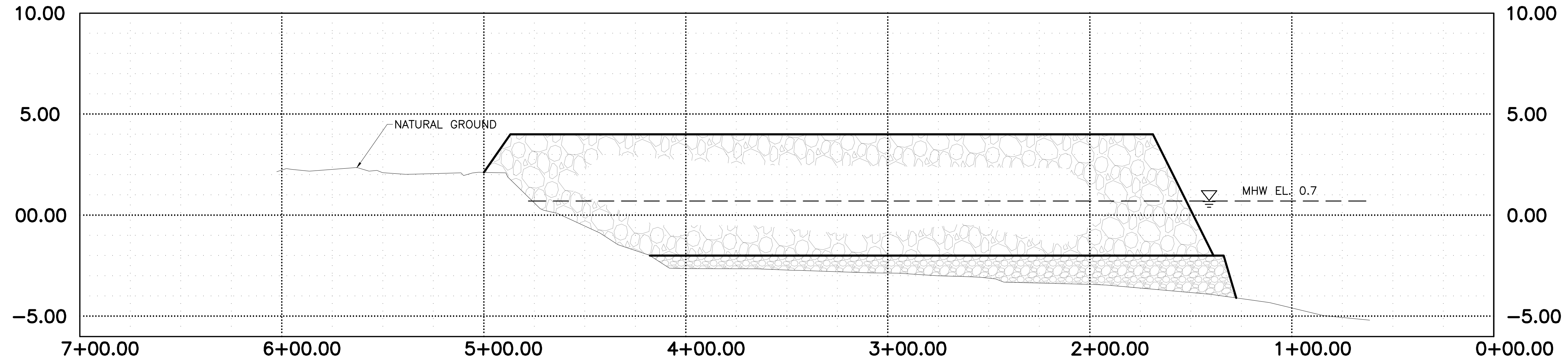

PROFILE OF BREAKWATER
(LOOKING EAST)

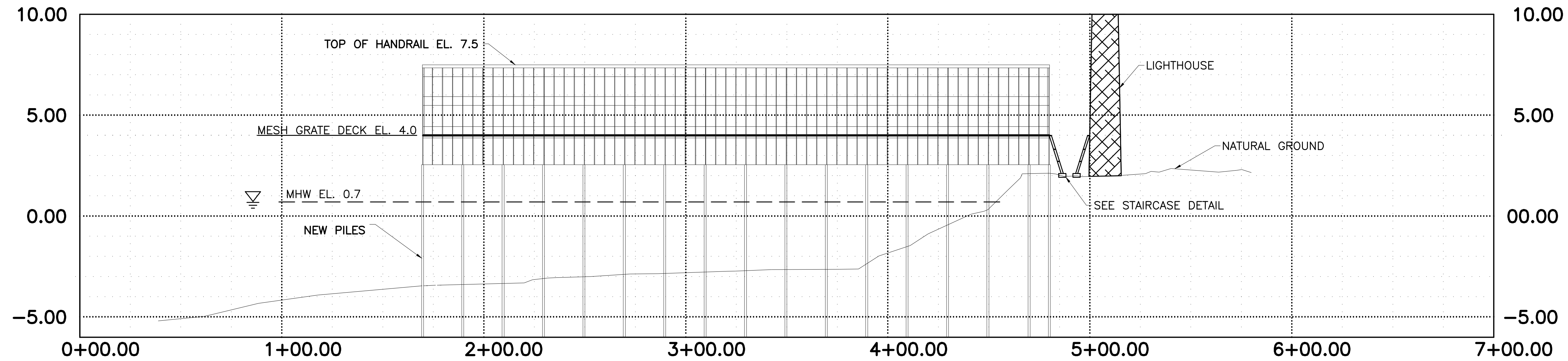
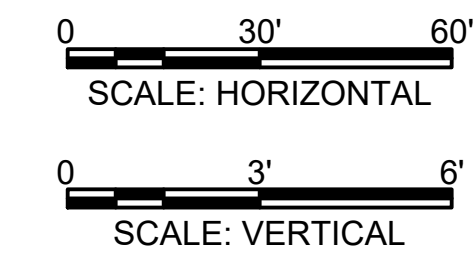

PROFILE OF PIER
(LOOKING WEST)

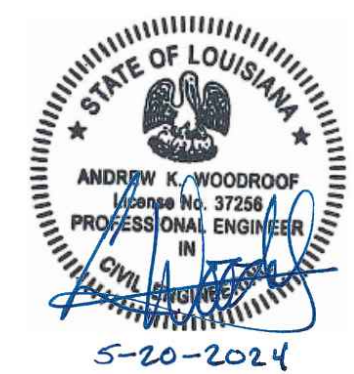

		PROJECT NO. DV20000135 DATE MAY 2024 SCALE SHEET NO. 8
TCHEFUNCTE HABITAT RESTORATION ST. TAMMANY PARISH, LOUISIANA		PROJECT MGR.: ANW APPROVED BY: RJD
527 W. ESPLANADE AVE., STE. 200 - KENNER, LA, 70065 - PH. (504) 468-6129 DRAWN BY: LAC CHECKED BY: ANW		REVISION DATE DESCRIPTION
DESIGNED BY: ANW CHECKED BY: RJD		BY

DWG PATH: s:\640 Maritime Museum\640-001\DWGS\ DWG NAME: _09_Bulkhead Details PLOT DATE: Monday, May 20, 2024 @ 8:10am

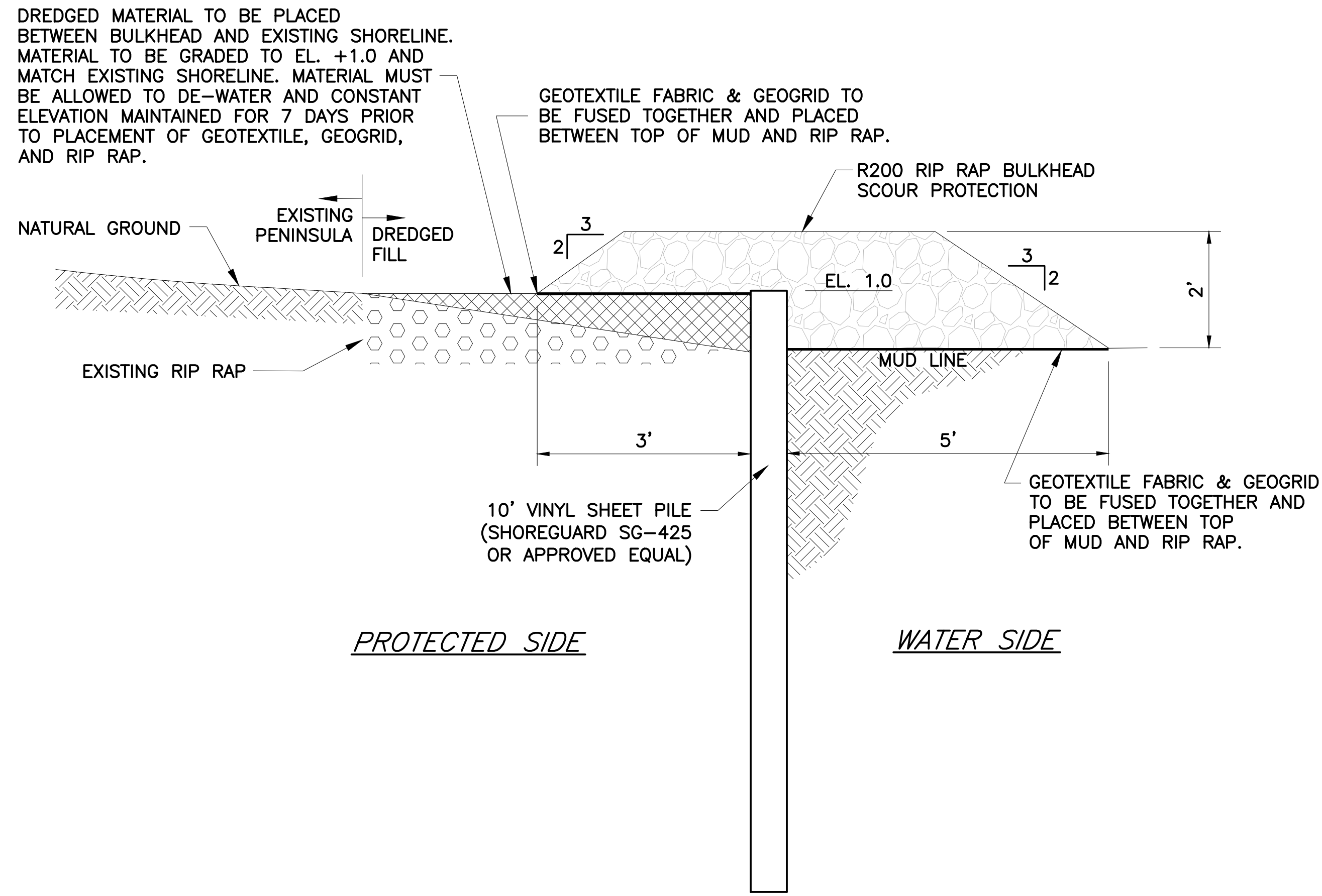

TYPICAL BULKHEAD SECTION
N.T.S. A
4 | 9

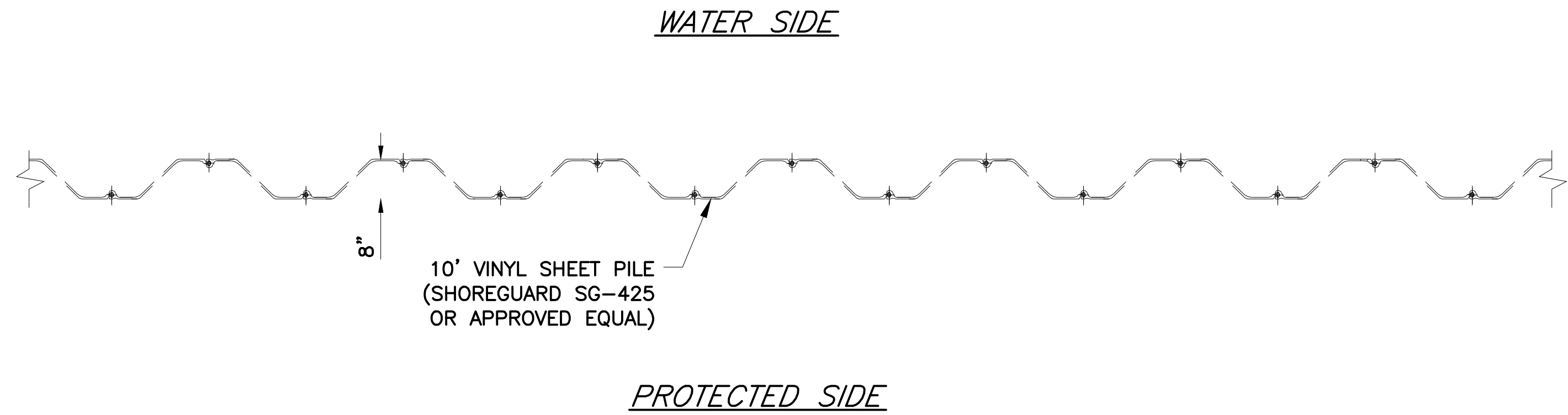

*NOTE:
3" TOTAL DEFLECTION TOLERANCE WHEN
PLACING VINYL SHEET PILE.

TYPICAL BULKHEAD LAYOUT
N.T.S.

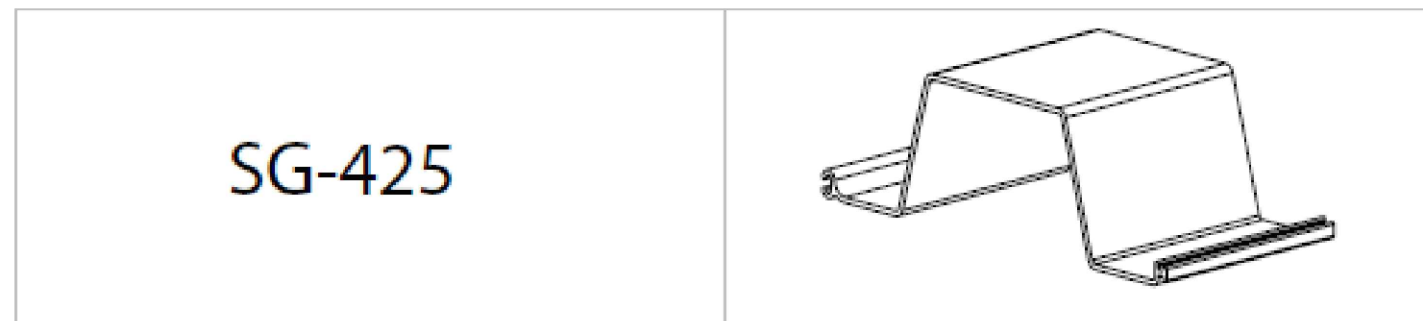

SG-425		
Allowable Moment (M)	3,813 ft-lb/ft	16.96 kN-m/m
Section Modulus (Z)	14.3 in ³ /ft	769 cm ³ /m
Moment of Inertia (I)	57 in ⁴ /ft	7,784 cm ⁴ /m
Impact Strength	13,750 in-lbs/in ²	2,406 N-mm/mm ²
Thickness (t)	0.285 in	7.2 mm
Section Depth	8.0 in	203 mm
Section Width	24 in	610 mm
Material	Weatherable Rigid Vinyl	
Standard Colors	Grey, Clay	
Technology	Box Profile, I-Beam Lock, XCR™	
Standard Packaging	20 sheets/bundle	

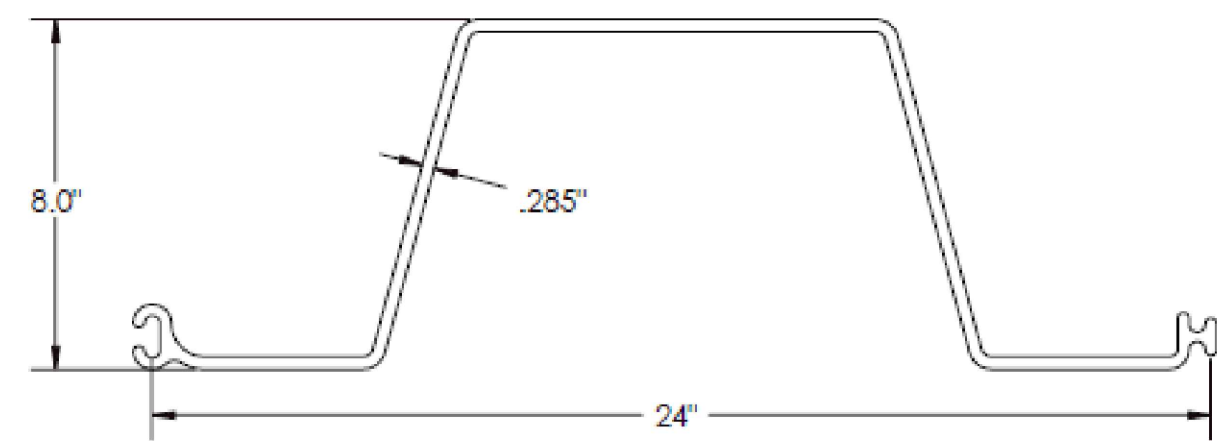

VINYL SHEETPILE PROPERTIES
N.T.S.

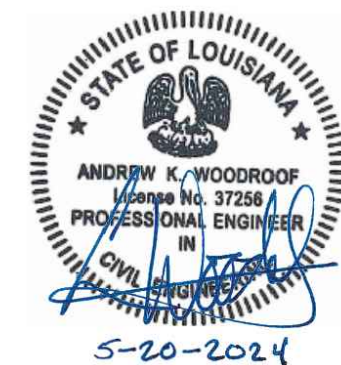

<p>527 W. ESPLANADE AVE., STE. 200 - KENNER, LA, 70065 - PH. (504) 468-6129</p> <p>DESIGNED BY: ANW DRAWN BY: LAC PROJECT MGR.: ANW APPROVED BY: RJD</p>	<p>TCHEFUNCTE HABITAT RESTORATION ST. TAMMANY PARISH, LOUISIANA</p> <p>BULKHEAD SECTIONS & DETAILS</p>								
<p>PROJECT NO. DV20000135</p> <p>DATE MAY 2024</p> <p>SCALE NOT TO SCALE</p> <p>SHEET NO. 9</p>	<table border="1" style="width: 100%; border-collapse: collapse;"> <tr> <th style="width: 50%;">REVISION</th> <th style="width: 50%;">DATE</th> <th style="width: 50%;">DESCRIPTION</th> <th style="width: 50%;">BY</th> </tr> <tr> <td> </td> <td> </td> <td> </td> <td> </td> </tr> </table>	REVISION	DATE	DESCRIPTION	BY				
REVISION	DATE	DESCRIPTION	BY						

DWG PATH: S:\640) Maritime Museum\640-001\DWGS
 DWG NAME: 10-11_Lateral CrossSection
 PLOT DATE: Monday, May 20, 2024 @ 8:10am
 LAYOUT TAB: 10

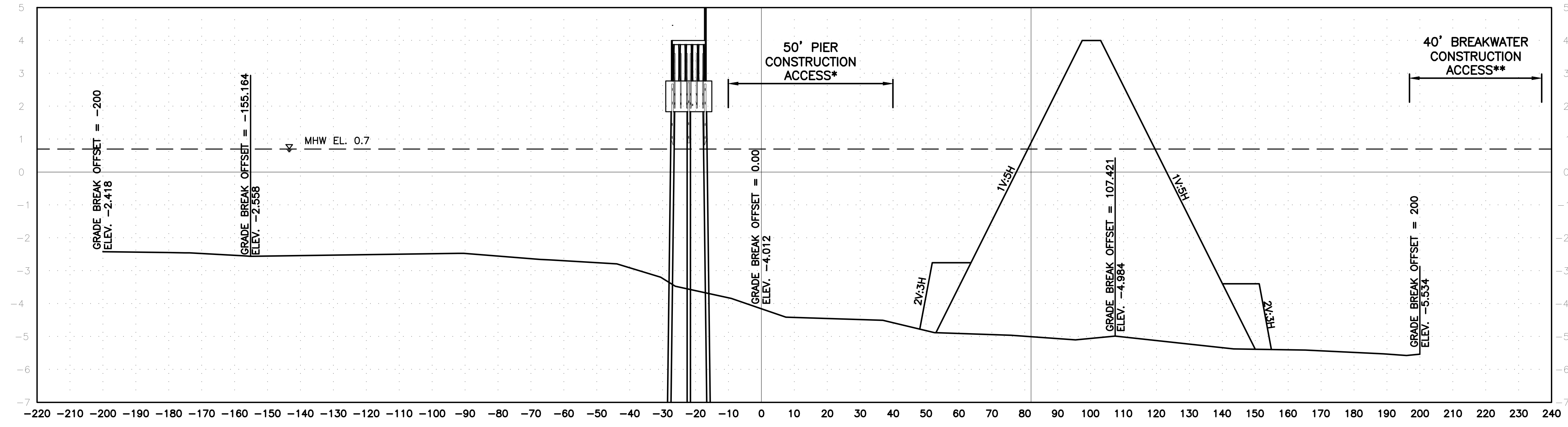

STATION 1+25.00

*MAXIMUM DRAFT FOR WORK VESSELS = 3'
 **MAXIMUM DRAFT FOR WORK VESSELS = 5'

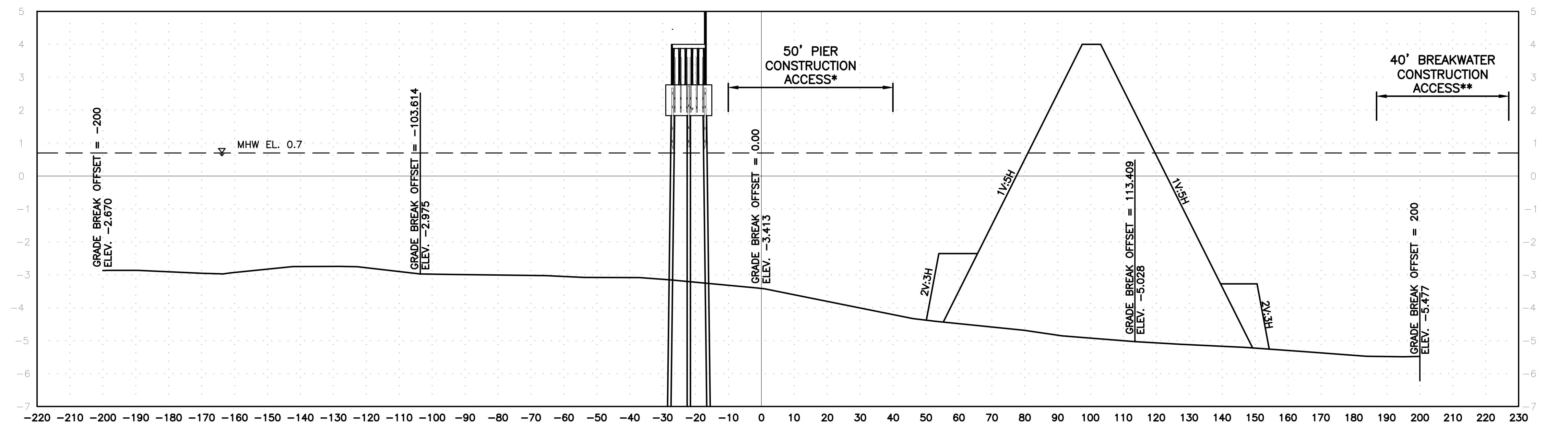

STATION 2+00



HORIZONTAL SCALE: 1"=20'
 VERTICAL SCALE: 1"=2'

TCHEFUNCTE HABITAT RESTORATION ST. TAMMANY PARISH, LOUISIANA		PROJECT NO. DV20000135	
DESIGNED BY: AKW DRAWN BY: LAC CHECKED BY: RJD		DATE MAY 2024	
digital engineering 527 W. ESPLANADE AVE., STE. 200 - KENNER, LA, 70065 - PH. (504) 468-6129 PROJECT MGR: AKW		SCALE	
CROSS SECTIONS		SHEET NO. 10	
REVISION	DATE	DESCRIPTION	BY

DWG PATH: S:\640) Maritime Museum (640-001)\DWGS
 DWG NAME: 10-11_Lateral CrossSection
 PLOT DATE: Monday, May 20, 2024 @ 8:10am

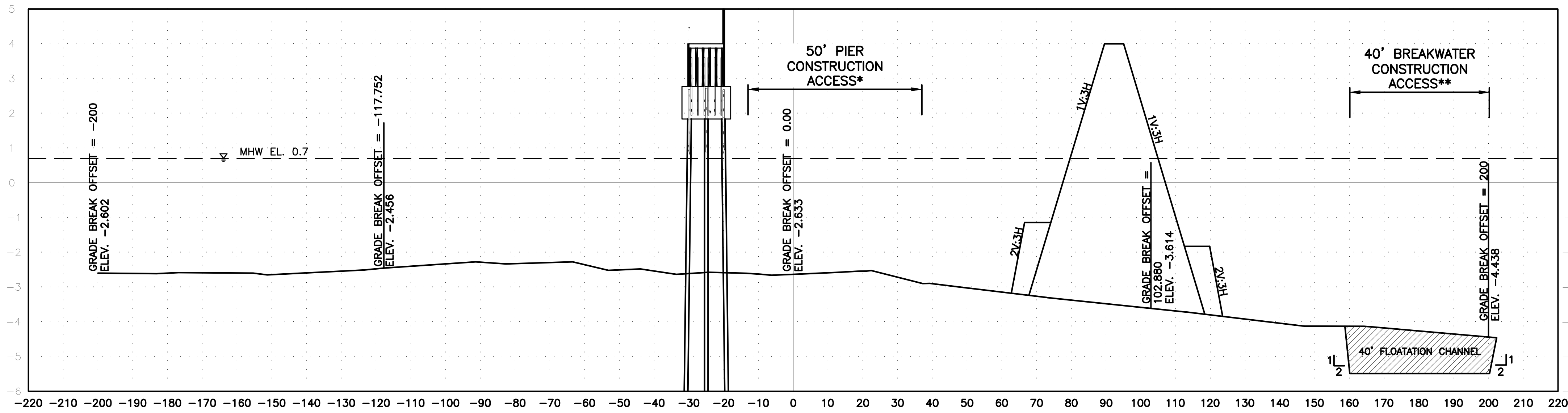

STATION 3+00

*MAXIMUM DRAFT FOR WORK VESSELS = 3'
 **MAXIMUM DRAFT FOR WORK VESSELS = 5'

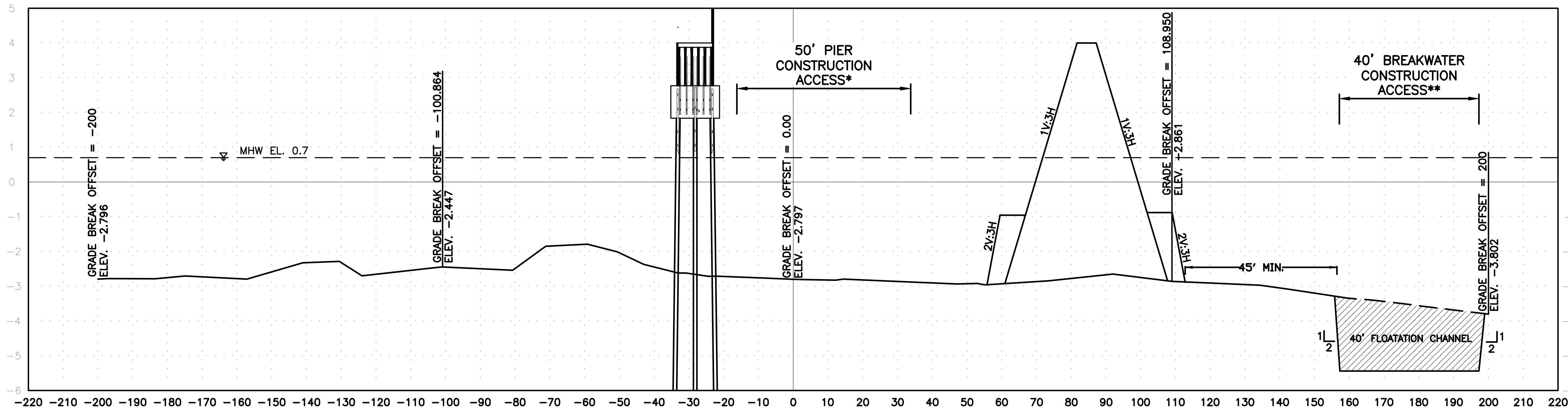

STATION 4+00

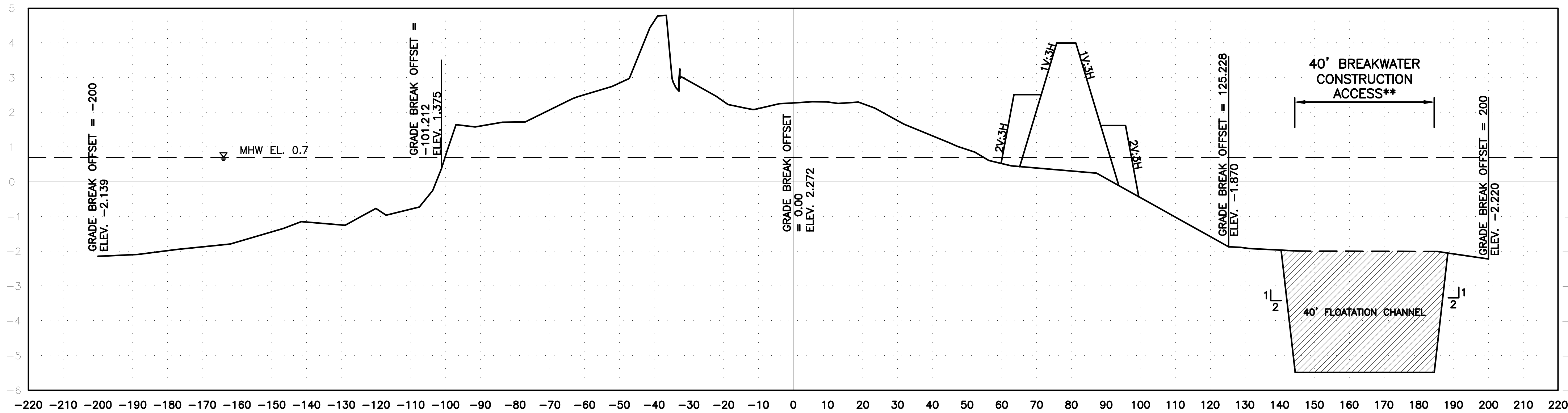

STATION 5+00

NOTE: MATERIAL REMOVED FROM FLOTATION CHANNEL TO BE PLACED ON PENINSULA AND SHALL BE GRADED TO (+1.0) ELEVATION (MATCH EXISTING GRADE).

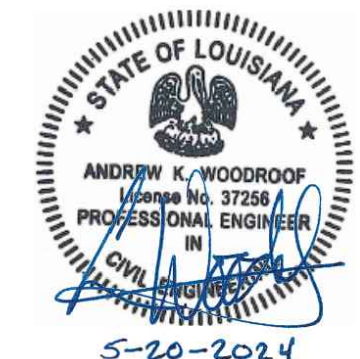

HORIZONTAL SCALE: 1"=20'
 VERTICAL SCALE: 1"=2'

PROJECT NO. DV20000135		DATE MAY 2024		SCALE		SHEET NO. 11	
PROJECT MGR: AKW		APPROVED BY: RJD		DRAWN BY: LAC		CHECKED BY: AKW	
DESIGNED BY: AKW		CHECKED BY: RJD		PROJECT MGR: AKW		APPROVED BY: RJD	
TCHEFUNCTE HABITAT RESTORATION ST. TAMMANY PARISH, LOUISIANA				CROSS SECTIONS			
digital engineering				527 W. ESPLANADE AVE., STE. 200 - KENNER, LA, 70065 - PH. (504) 468-6129			
DESCRIPTION		DATE		REVISION		BY	

TOP OF LANTERN ELEVATION = 12.75'

TIDELAND SOLAMAX USCG APPROVED MARINE LANTERN WITH FLASH CHARACTERISTIC FL2.5S OR APPROVED EQUAL.

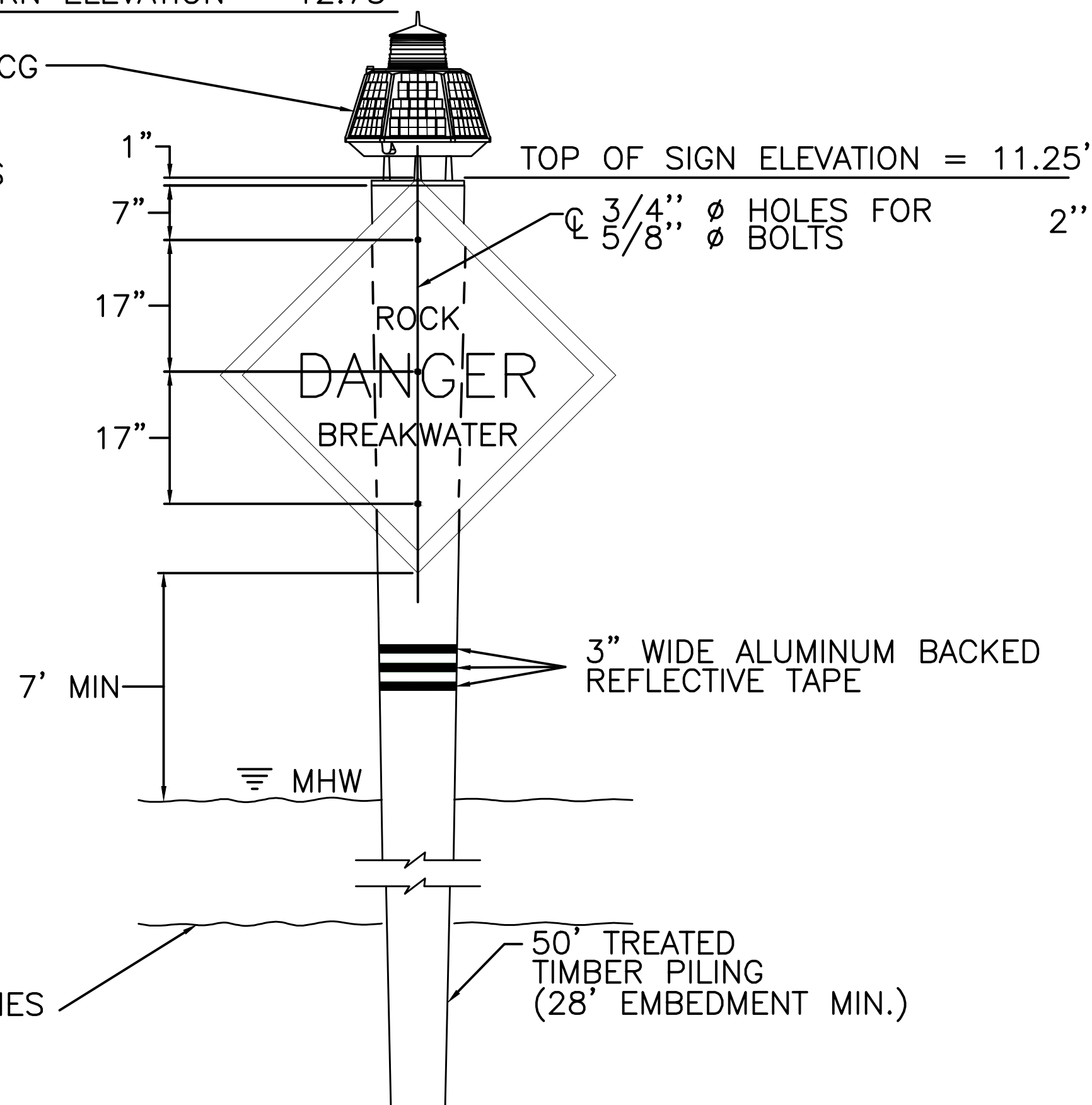

WARNING SIGN ELEVATION

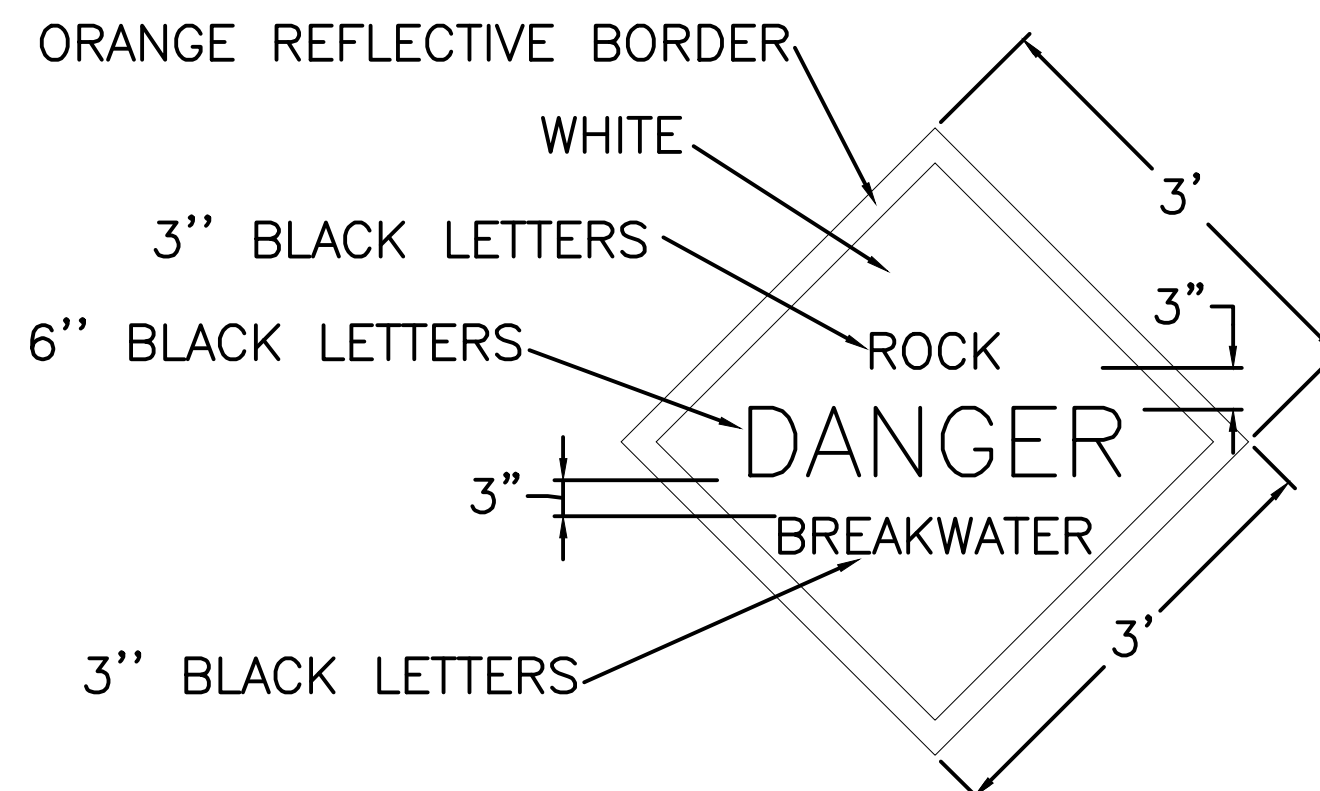

SIGN DETAIL

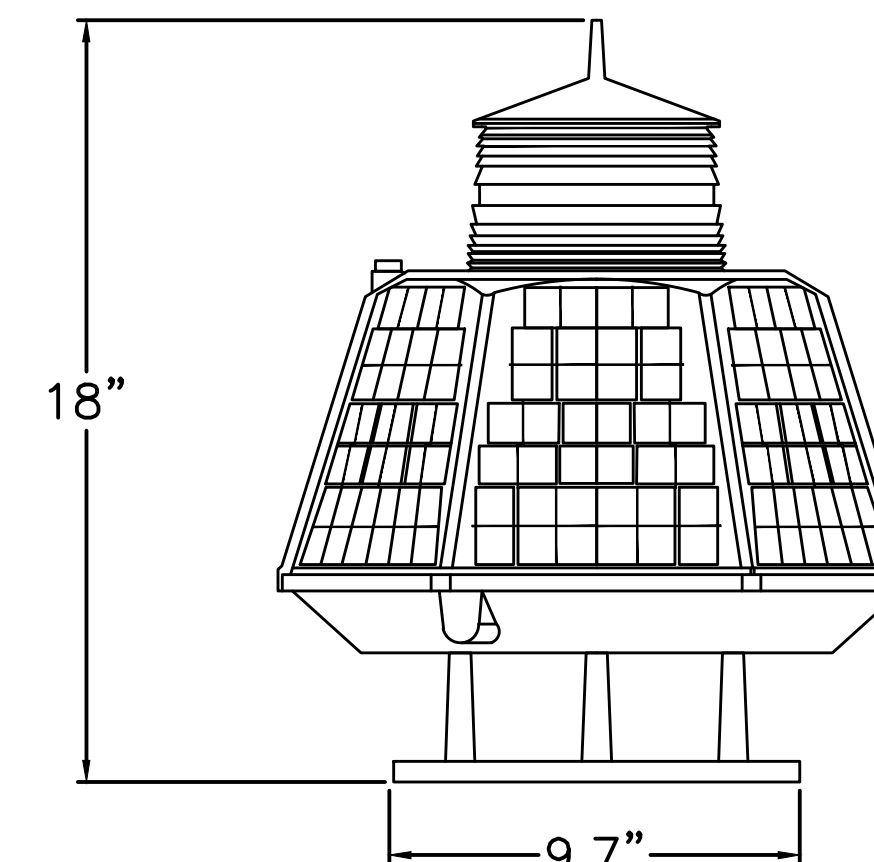

MARINE LANTERN DETAIL

NOTES:

1. REFERENCES HEREIN TO THE "STANDARD SPECIFICATIONS" REFER TO THE "LA STANDARD SPECIFICATIONS FOR ROADS AND BRIDGES", LATEST EDITION, INCLUDING AMENDMENTS, BY THE DEPT. OF TRANSPORTATION AND DEVELOPMENT. MEASUREMENT AND PAYMENT WILL BE MADE AS DESCRIBED THEREIN, EXCEPT WHERE STATED OTHERWISE.
2. PERMANENT WARNING SIGNS (TWO PER PILE) SHALL BE INSTALLED APPROXIMATELY 15 FEET IN FRONT OF STRUCTURE AS SHOWN ON THE DRAWINGS OR AS DIRECTED BY THE PROJECT ENGINEER. WARNING SIGNS SHALL BE PLACED EVERY 300 FEET CENTERED ON END AND SPACED ON EACH SIDE OF STRUCTURE. APPROXIMATE LOCATIONS OF THE WARNING SIGNS ARE SHOWN ON SHEET 4. ACTUAL LOCATIONS WILL BE DETERMINED IN THE FIELD BY ENGINEER.
3. TEMPORARY WARNING SIGNS (TWO PER PILE) SHALL BE INSTALLED APPROXIMATELY 15 FEET IN FRONT OF SPOIL BANK AREA AS SHOWN ON THE DRAWINGS OR AS DIRECTED BY THE PROJECT ENGINEER. WARNING SIGNS SHALL BE PLACED EVERY 300 FEET TO TEMPORARILY MARK THE SPOIL BANK AREA UNTIL ALL NAVIGATION OBSTRUCTIONS RELATED TO THE SPOIL BANK ARE REMOVED. APPROXIMATE LOCATIONS OF THE WARNING SIGNS ARE SHOWN ON SHEET 7. ACTUAL LOCATIONS WILL BE DETERMINED IN THE FIELD BY ENGINEER.
4. THE 2" BORDER ON THE WARNING SIGN WILL BE A REFLECTIVE MATERIAL OF ORANGE COLOR. THE LETTERING FIELD WILL BE A REFLECTIVE MATERIAL OF WHITE COLOR. THE LETTERING FOR THE WARNING SIGNS WILL BE BLACK. ALL SIGNS MUST MEET U.S. COAST GUARD STANDARDS; IN ACCORDANCE WITH 33 CFR 330.4 (a) (1). 4. NEOPRENE WASHERS SHALL BE PLACED BETWEEN THE SIGN AND THE PILING AT ALL POINTS OF CONTACT.
5. HARDWARE FOR TIMBER CONNECTIONS SHALL BE HOT DIP GALVANIZED IN ACCORDANCE WITH SECTION 811.15 OF THE LOUISIANA STANDARD SPECIFICATIONS FOR ROADS AND BRIDGES, AS PUBLISHED BY THE LOUISIANA DEPARTMENT OF TRANSPORTATION AND DEVELOPMENT, LATEST EDITION.
6. TIMBER PILES SHALL CONFORM TO SECTIONS 804 AND 1014 OF THE LOUISIANA STANDARD SPECIFICATIONS FOR ROADS AND BRIDGES, AS PUBLISHED BY THE LOUISIANA DEPARTMENT OF TRANSPORTATION AND DEVELOPMENT, LATEST EDITION. PILES SHALL BE TREATED WITH A CREOSOTE SOLUTION CONFORMING TO AWPA P2 TO A MINIMUM RETENTION OF 16 PCF OR AWPA TREATMENT CI USING WATER BORNE ACA OR CCA PRESERVATIVE WITH 2.5 lb/ft RETENTION.
7. TIMBER PILING SHALL BE 50- FEET IN LENGTH WITH A 12- INCH DIAMETER BUTT AND 7- INCH DIAMETER AT THE TIP.
8. EXPOSED BOLT THREADS SHALL BE EITHER TACK WELDED TO NUTS, STRIPPED, OR DAMAGED BY OTHER APPROVED METHOD TO PREVENT EASY REMOVAL.

TOP OF LANTERN ELEVATION = 12.75'

TOP OF SIGN ELEVATION = 11.25'

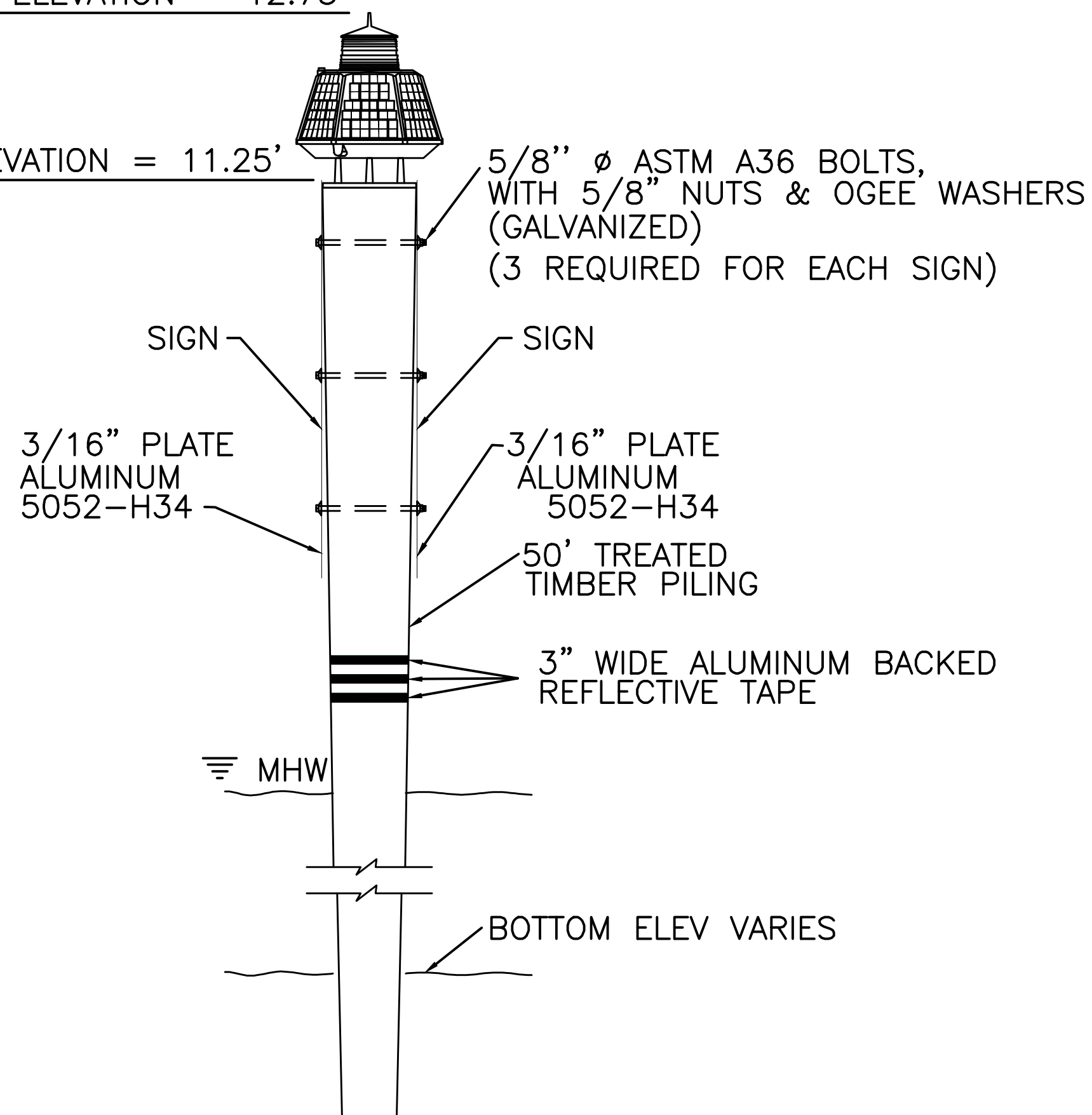

WARNING SIGN SIDE DETAIL

DWG PATH: s:\640 Maritime Museum\640-001\DWGS\12_WarningsSigns
 DWG NAME: 12_WarningsSigns
 PLOT DATE: Monday, May 20, 2024 @ 8:10am

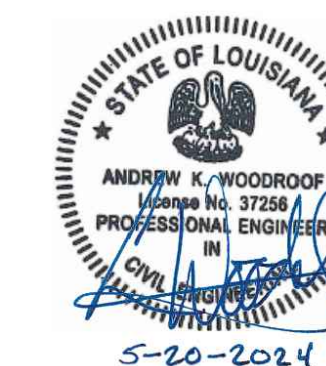

PROJECT NO. DV20000135		DATE MAY 2024		SCALE NONE		SHEET NO. 12	
TCHEFUNCTE HABITAT RESTORATION ST. TAMMANY PARISH, LOUISIANA		DESIGNED BY: AW		DRAWN BY: LAC		CHECKED BY: AW	
MARINE HAZARD MARKER DETAILS		PROJECT MGR.: AW		APPROVED BY: RJD		REVISION	
						DATE	
						DESCRIPTION	
						BY	

DWG PATH: S:\640 Maritime Museum\640-001\DWGS\13_TURBIDITY Details
 DWG NAME: 13_TURBIDITY Details
 PLOT DATE: Monday, May 20, 2024 @ 8:10am

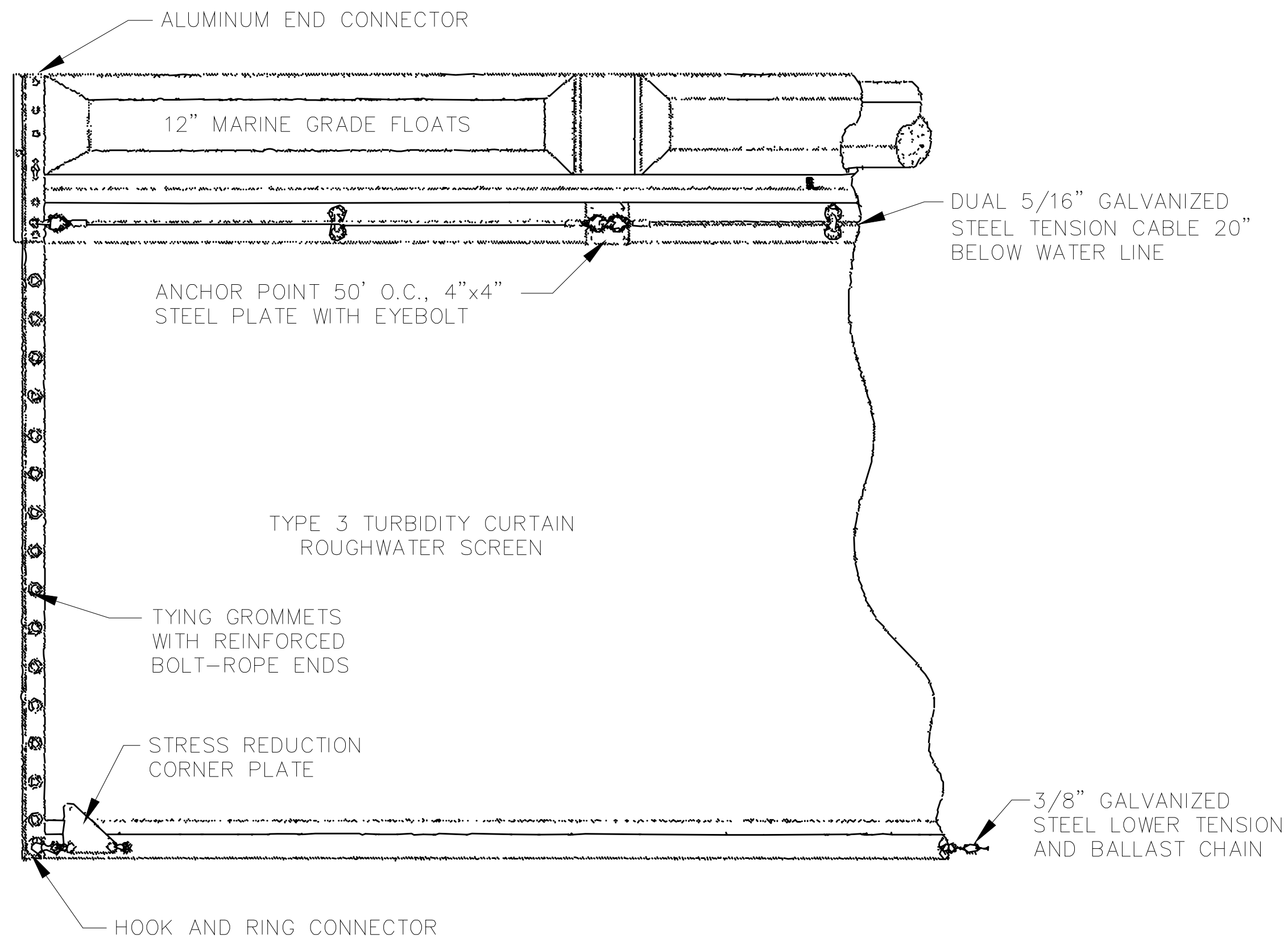

ELEVATION VIEW
 ROUGHWATER HEAVY DUTY
 TYPE 3 SILT BARRIER
 (NOT TO SCALE)

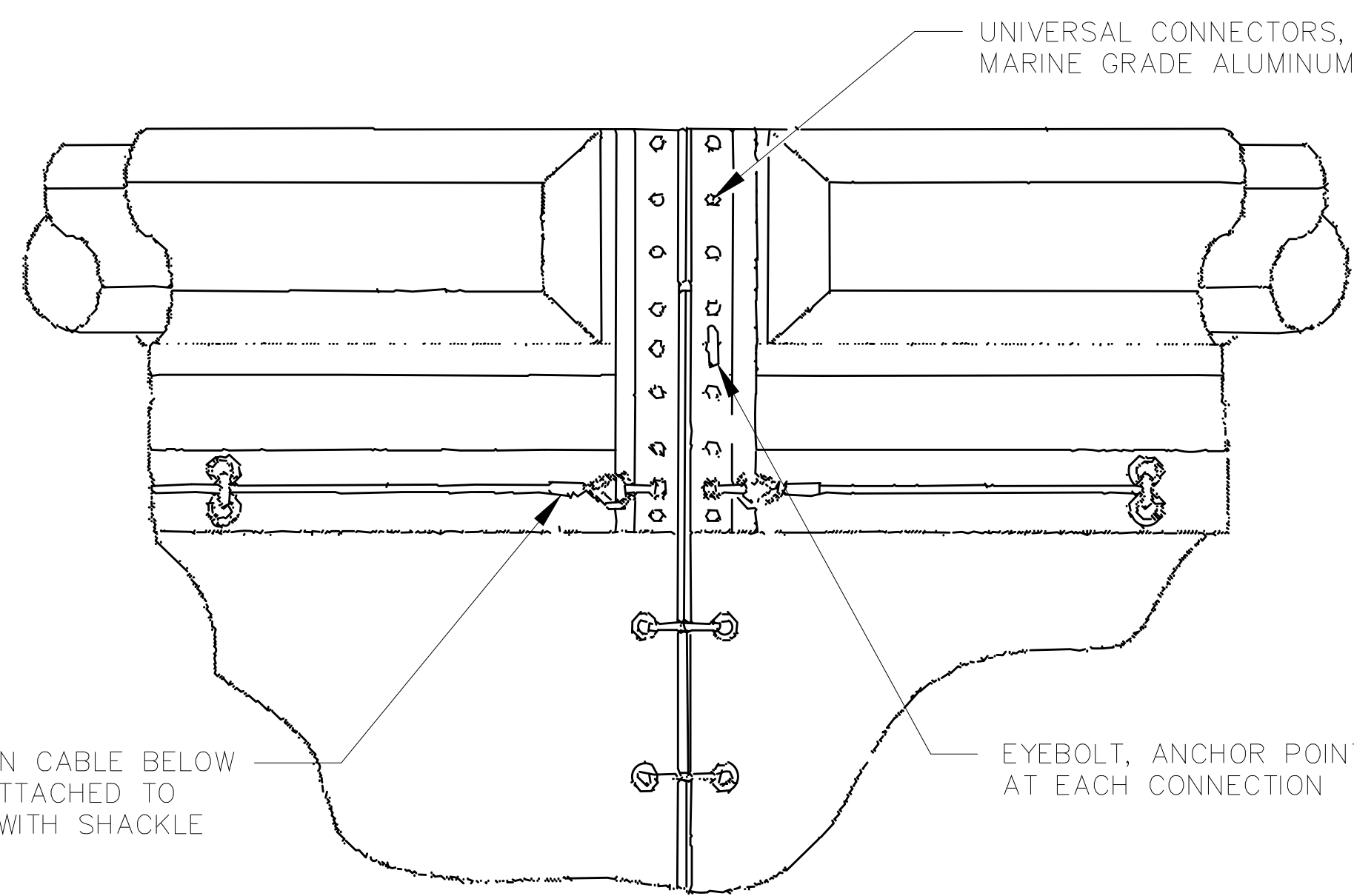

DETAIL VIEW
 ROUGHWATER HEAVY DUTY
 TYPE 3 SILT BARRIER
 (NOT TO SCALE)

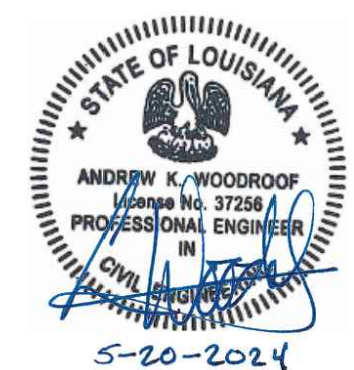
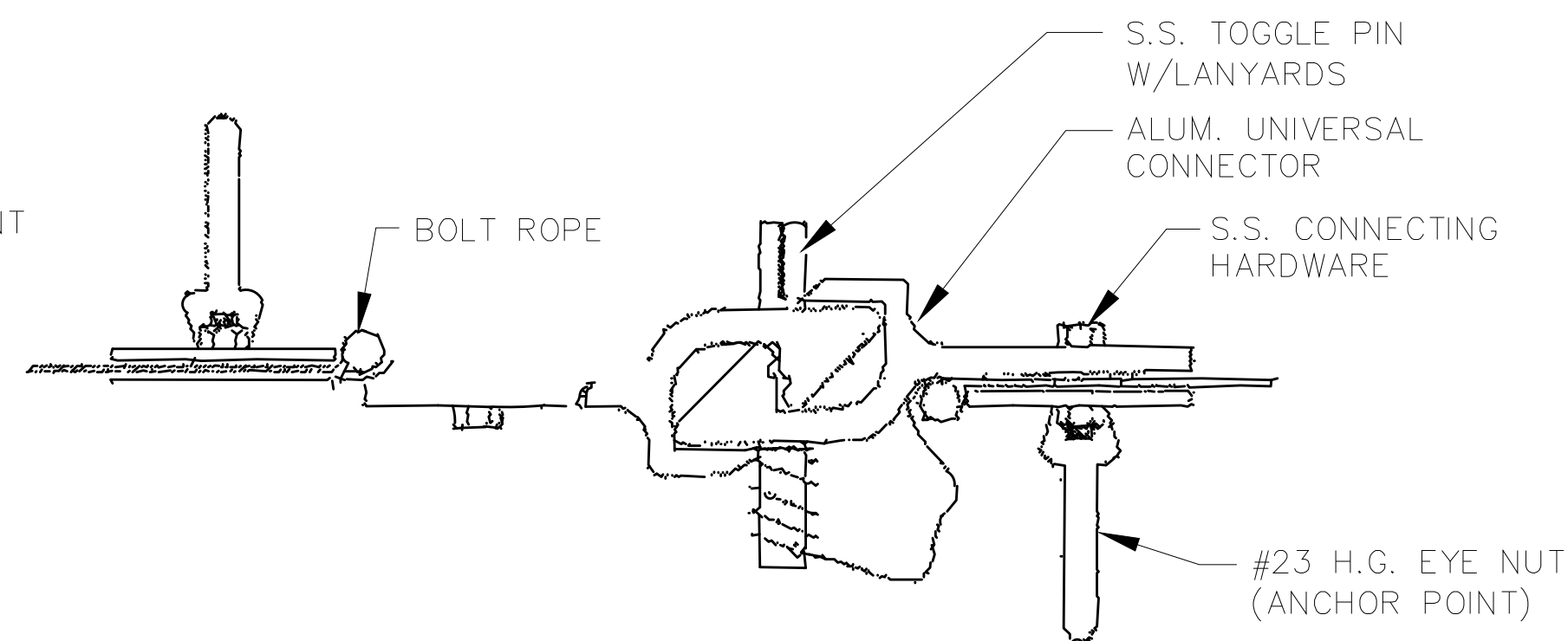

PROJECT NO. DV20000135	
DATE	MAY 2024
SCALE	NONE
SHEET NO.	13
TCHEFUNCTE HABITAT RESTORATION ST. TAMMANY PARISH, LOUISIANA	
TURBIDITY CURTAIN DETAILS	
DESIGNED BY: AW	CHECKED BY: AW
DRAWN BY: LAC	CHECKED BY: AW
PROJECT MGR.: AW	APPROVED BY: RJD
527 W. ESPLANADE AVE., STE. 200 - KENNER, LA, 70065 - PH. (504) 468-6129	
REVISION	DATE
DESCRIPTION	BY

10.0 Required Contract Provisions by Granting Agency

1. EPA
2. DOE
3. USDA
4. FEMA
5. HUD
6. FAA
7. FTA
8. DOI (GOMESA)

NOTE: The Department where the grant originated is responsible for determining if the granting agency has any additional required clauses specific to any particular grant OR if extended provisions are required. The clauses below effect the most basic compliance with the CFR's for many, but not all, grant programs. Many agencies have additional clauses that are not listed here.

Environmental Protection Agency (EPA)
40 CFR 31.36

1. Equal Employment Opportunity

The Contractor agrees to comply with Executive Order 11246 of September 24, 1965 entitled “Equal Employment Opportunity,” as amended by Executive Order 11375 of October 13, 1967, and as supplemented in Department of Labor regulations (41 CFR Chapter 60).

2. Copeland Anti-Kickback Act

The Contractor agrees to comply with the Copeland “Anti-Kickback” Act (18 U.S.C. 874) as supplemented in Department of Labor regulations (29 CFR Part 3). These regulations are herein incorporated by reference in this contract.

3. Davis Bacon and Related Acts

The Contractor agrees to comply with the Davis-Bacon Act (40 U.S.C. 276a to 276a-7) as supplemented by Department of Labor regulations (29 CFR Part 5). These regulations are herein incorporated by reference in this contract.

4. Contract Work Hours and Safety Standards Act

The Contractor agrees to comply with Sections 103 and 107 of the Contract Work Hours and Safety Standards Act (40 U.S.C. 327-330) as supplemented by Department of Labor regulations (29 CFR Part 5). These regulations are herein incorporated by reference in this contract.

5. Rights to Inventions, Copyrights, and Rights in Data

The Contractor agrees to comply with requirements and regulations pertaining to copyrights and rights in data.

6. Records Access and Retention

The Contractor agrees to grant access by Parish, the State, Federal agencies, the Comptroller General of the United States, or any of their duly authorized representatives to any books, documents, papers, and records of the contractor which are directly pertinent to that specific contract for the purpose of making audit, examination, excerpts, and transcriptions.

The Contractor agrees to retain all required records for three (3) years after final payments have been made and/or all other pending matters are closed.

7. Debarment and Suspension

The Contractor is prohibited from awarding any subcontract expected to equal or exceed \$25,000 to persons (individuals or organizations) listed on the Excluded Parties List System (EPLS) which is available at www.epls.gov.

8. Energy and Environmental Conservation

The Contractor agrees to comply with mandatory standards and policies relating to energy efficiency which are contained in the state energy conservation plan issued in compliance with the Energy Policy and Conservation Act (Pub. L. 94-163, 89 Stat. 871). [53 FR 8045, 8087, Mar. 11, 1998, as amended at 60 FR 19639, 19641, Apr. 19, 1995; 61 FR 7166, Feb. 26, 1996]. These regulations are herein incorporated by reference in this contract.

9. Byrd Anti-Lobbying Amendment

The Contractor agrees to comply with the requirements of the Byrd Anti-Lobbying Amendment. The Contractor certifies that it will not and has not used Federal appropriated funds to pay any person or organization for influencing or attempting to influence an officer or employee of any agency, a member of Congress, officer or employee of Congress, or an employee of a member of Congress in connection with obtaining any Federal contract, grant or any other award covered by 1 U.S.C. 1352. The Contractor shall disclose any lobbying with non-Federal funds that takes place in connection with obtaining any Federal award.

10. Reporting

The Contractor agrees to comply with all Federal, State, and Parish requirements and regulations pertaining to reporting on projects receiving Federal, State, or Parish funding.

11. Clean Air and Water Acts

The Contractor agrees to comply with all applicable standards, orders, or requirements issued under section 306 of the Clean Air Act (42 U.S.C. 1857(h)), section 508 of the Clean Water Act (33 U.S.C. 1368), Executive Order 11738, and Environmental Protection Agency regulations (40 CFR Part 15). These regulations are herein incorporated by reference in this contract.

12. Legal Remedies

Contracts must include administrative, contractual, and legal remedies for use in cases in which contractors violate or breach contract terms. The contract must also make clear the remedial actions which you may take.

13. Termination

Contracts in excess of \$10,000 must explain the conditions under which you may terminate them for cause or for your convenience, including the process for bringing about the termination and the basis for settlement.

More information regarding the above provisions can be found on the common drive at the following location:

Y:\Federal Programs Common\FED PROCUREMENT DOCTS\Components\EPA

Department of Energy (DOE)
7 CFR 600.236

1. Equal Employment Opportunity

The Contractor agrees to comply with Executive Order 11246 of September 24, 1965 entitled “Equal Employment Opportunity,” as amended by Executive Order 11375 of October 13, 1967, and as supplemented in Department of Labor regulations (41 CFR Chapter 60).

2. Copeland Anti-Kickback Act

The Contractor agrees to comply with the Copeland “Anti-Kickback” Act (18 U.S.C. 874) as supplemented in Department of Labor regulations (29 CFR Part 3). These regulations are herein incorporated by reference in this contract.

3. Davis Bacon and Related Acts

The Contractor agrees to comply with the Davis-Bacon Act (40 U.S.C. 276a to 276a-7) as supplemented by Department of Labor regulations (29 CFR Part 5). These regulations are herein incorporated by reference in this contract.

4. Contract Work Hours and Safety Standards Act

The Contractor agrees to comply with Sections 103 and 107 of the Contract Work Hours and Safety Standards Act (40 U.S.C. 327-330) as supplemented by Department of Labor regulations (29 CFR Part 5). These regulations are herein incorporated by reference in this contract.

5. Rights to Inventions, Copyrights, and Rights in Data

The Contractor agrees to comply with requirements and regulations pertaining to copyrights and rights in data.

6. Records Access and Retention

The Contractor agrees to grant access by Parish, the State, Federal agencies, the Comptroller General of the United States, or any of their duly authorized representatives to any books, documents, papers, and records of the contractor which are directly pertinent to that specific contract for the purpose of making audit, examination, excerpts, and transcriptions.

The Contractor agrees to retain all required records for three (3) years after final payments have been made and/or all other pending matters are closed.

7. Debarment and Suspension

The Contractor is prohibited from awarding any subcontract expected to equal or exceed \$25,000 to persons (individuals or organizations) listed on the Excluded Parties List System (EPLS) which is available at www.epls.gov.

8. Energy and Environmental Conservation

The Contractor agrees to comply with mandatory standards and policies relating to energy efficiency which are contained in the state energy conservation plan issued in compliance with the Energy Policy and Conservation Act (Pub. L. 94-163, 89 Stat. 871). [53 FR 8045, 8087, Mar. 11, 1998, as amended at 60 FR 19639, 19641, Apr. 19, 1995; 61 FR 7166, Feb. 26, 1996]. These regulations are herein incorporated by reference in this contract.

9. Byrd Anti-Lobbying Amendment

The Contractor agrees to comply with the requirements of the Byrd Anti-Lobbying Amendment. The Contractor certifies that it will not and has not used Federal appropriated funds to pay any person or organization for influencing or attempting to influence an officer or employee of any agency, a member of Congress, officer or employee of Congress, or an employee of a member of Congress in connection with obtaining any Federal contract, grant or any other award covered by 1 U.S.C. 1352. The Contractor shall disclose any lobbying with non-Federal funds that takes place in connection with obtaining any Federal award.

10. Reporting

The Contractor agrees to comply with all Federal, State, and Parish requirements and regulations pertaining to reporting on projects receiving Federal, State, or Parish funding.

11. Clean Air and Water Acts

The Contractor agrees to comply with all applicable standards, orders, or requirements issued under section 306 of the Clean Air Act (42 U.S.C. 1857(h)), section 508 of the Clean Water Act (33 U.S.C. 1368), Executive Order 11738, and Environmental Protection Agency regulations (40 CFR Part 15). These regulations are herein incorporated by reference in this contract.

12. Legal Remedies

Contracts must include administrative, contractual, and legal remedies for use in cases in which contractors violate or breach contract terms. The contract must also make clear the remedial actions which you may take.

13. Termination

Contracts in excess of \$10,000 must explain the conditions under which you may terminate them for cause or for your convenience, including the process for bringing about the termination and the basis for settlement.

More information regarding the above provisions can be found on the common drive at the following location:

Y:\Federal Programs Common\FED PROCUREMENT DOCTS\Components\DOE

United States Department of Agriculture (USDA)
10 CFR 3016.36

1. Equal Employment Opportunity

The Contractor agrees to comply with Executive Order 11246 of September 24, 1965 entitled “Equal Employment Opportunity,” as amended by Executive Order 11375 of October 13, 1967, and as supplemented in Department of Labor regulations (41 CFR Chapter 60).

2. Copeland Anti-Kickback Act

The Contractor agrees to comply with the Copeland “Anti-Kickback” Act (18 U.S.C. 874) as supplemented in Department of Labor regulations (29 CFR Part 3). These regulations are herein incorporated by reference in this contract.

3. Davis Bacon and Related Acts

The Contractor agrees to comply with the Davis-Bacon Act (40 U.S.C. 276a to 276a-7) as supplemented by Department of Labor regulations (29 CFR Part 5). These regulations are herein incorporated by reference in this contract.

4. Contract Work Hours and Safety Standards Act

The Contractor agrees to comply with Sections 103 and 107 of the Contract Work Hours and Safety Standards Act (40 U.S.C. 327-330) as supplemented by Department of Labor regulations (29 CFR Part 5). These regulations are herein incorporated by reference in this contract.

5. Rights to Inventions, Copyrights, and Rights in Data

The Contractor agrees to comply with requirements and regulations pertaining to copyrights and rights in data.

6. Records Access and Retention

The Contractor agrees to grant access by Parish, the State, Federal agencies, the Comptroller General of the United States, or any of their duly authorized representatives to any books, documents, papers, and records of the contractor which are directly pertinent to that specific contract for the purpose of making audit, examination, excerpts, and transcriptions.

The Contractor agrees to retain all required records for three (3) years after final payments have been made and/or all other pending matters are closed.

7. Debarment and Suspension

The Contractor is prohibited from awarding any subcontract expected to equal or exceed \$25,000 to persons (individuals or organizations) listed on the Excluded Parties List System (EPLS) which is available at www.epls.gov.

8. Energy and Environmental Conservation

The Contractor agrees to comply with mandatory standards and policies relating to energy efficiency which are contained in the state energy conservation plan issued in compliance with the Energy Policy and Conservation Act (Pub. L. 94-163, 89 Stat. 871). [53 FR 8045, 8087, Mar. 11, 1998, as amended at 60 FR 19639, 19641, Apr. 19, 1995; 61 FR 7166, Feb. 26, 1996]. These regulations are herein incorporated by reference in this contract.

9. Reporting

The Contractor agrees to comply with all Federal, State, and Parish requirements and regulations pertaining to reporting on projects receiving Federal, State, or Parish funding.

10. Clean Air and Water Acts

The Contractor agrees to comply with all applicable standards, orders, or requirements issued under section 306 of the Clean Air Act (42 U.S.C. 1857(h)), section 508 of the Clean Water Act (33 U.S.C. 1368), Executive Order 11738, and Environmental Protection Agency regulations (40 CFR Part 15). These regulations are herein incorporated by reference in this contract.

11. Legal Remedies

Contracts must include administrative, contractual, and legal remedies for use in cases in which contractors violate or breach contract terms. The contract must also make clear the remedial actions which you may take.

12. Termination

Contracts in excess of \$10,000 must explain the conditions under which you may terminate them for cause or for your convenience, including the process for bringing about the termination and the basis for settlement.

More information regarding the above provisions can be found on the common drive at the following location:

Y:\Federal Programs Common\FED PROCUREMENT DOCTS\Components\USDA

Federal Emergency Management Agency (FEMA)
44 CFR 13.36

1. Equal Employment Opportunity

The Contractor agrees to comply with Executive Order 11246 of September 24, 1965 entitled “Equal Employment Opportunity,” as amended by Executive Order 11375 of October 13, 1967, and as supplemented in Department of Labor regulations (41 CFR Chapter 60).

2. Copeland Anti-Kickback Act

The Contractor agrees to comply with the Copeland “Anti-Kickback” Act (18 U.S.C. 874) as supplemented in Department of Labor regulations (29 CFR Part 3). These regulations are herein incorporated by reference in this contract.

3. Davis Bacon and Related Acts

The Contractor agrees to comply with the Davis-Bacon Act (40 U.S.C. 276a to 276a-7) as supplemented by Department of Labor regulations (29 CFR Part 5). These regulations are herein incorporated by reference in this contract.

4. Contract Work Hours and Safety Standards Act

The Contractor agrees to comply with Sections 103 and 107 of the Contract Work Hours and Safety Standards Act (40 U.S.C. 327-330) as supplemented by Department of Labor regulations (29 CFR Part 5). These regulations are herein incorporated by reference in this contract.

5. Rights to Inventions, Copyrights, and Rights in Data

The Contractor agrees to comply with requirements and regulations pertaining to copyrights and rights in data.

6. Records Access and Retention

The Contractor agrees to grant access by Parish, the State, Federal agencies, the Comptroller General of the United States, or any of their duly authorized representatives to any books, documents, papers, and records of the contractor which are directly pertinent to that specific contract for the purpose of making audit, examination, excerpts, and transcriptions.

The Contractor agrees to retain all required records for three (3) years after final payments have been made and/or all other pending matters are closed.

7. Debarment and Suspension

The Contractor is prohibited from awarding any subcontract expected to equal or exceed \$25,000 to persons (individuals or organizations) listed on the Excluded Parties List System (EPLS) which is available at www.epls.gov.

8. Energy and Environmental Conservation

The Contractor agrees to comply with mandatory standards and policies relating to energy efficiency which are contained in the state energy conservation plan issued in compliance with the Energy Policy and Conservation Act (Pub. L. 94-163, 89 Stat. 871). [53 FR 8045, 8087, Mar. 11, 1998, as amended at 60 FR 19639, 19641, Apr. 19, 1995; 61 FR 7166, Feb. 26, 1996]. These regulations are herein incorporated by reference in this contract.

9. Reporting

The Contractor agrees to comply with all Federal, State, and Parish requirements and regulations pertaining to reporting on projects receiving Federal, State, or Parish funding.

10. Clean Air and Water Acts

The Contractor agrees to comply with all applicable standards, orders, or requirements issued under section 306 of the Clean Air Act (42 U.S.C. 1857(h)), section 508 of the Clean Water Act (33 U.S.C. 1368), Executive Order 11738, and Environmental Protection Agency regulations (40 CFR Part 15). These regulations are herein incorporated by reference in this contract.

11. Legal Remedies

Contracts must include administrative, contractual, and legal remedies for use in cases in which contractors violate or breach contract terms. The contract must also make clear the remedial actions which you may take.

12. Termination

Contracts in excess of \$10,000 must explain the conditions under which you may terminate them for cause or for your convenience, including the process for bringing about the termination and the basis for settlement.

13. Release of Funds

The Contractor agrees that no award, or execution of contract, or Notice to Proceed, will occur until a Release of Funds is issued by HUD for CDBG-DR Disaster Recovery funds.

14. Section 3

The Contractor agrees to comply with all applicable standards, orders, or requirements issued under Section 3 of the Housing and Urban Development Act of 1968, as amended, 12 U.S.C. 1701u (section 3).

Housing and Urban Development (HUD)
24 CFR 85.36

1. Equal Employment Opportunity

The Contractor agrees to comply with Executive Order 11246 of September 24, 1965 entitled "Equal Employment Opportunity," as amended by Executive Order 11375 of October 13, 1967, and as supplemented in Department of Labor regulations (41 CFR Chapter 60).

2. Copeland Anti-Kickback Act

The Contractor agrees to comply with the Copeland "Anti-Kickback" Act (18 U.S.C. 874) as supplemented in Department of Labor regulations (29 CFR Part 3). These regulations are herein incorporated by reference in this contract.

3. Davis Bacon and Related Acts

The Contractor agrees to comply with the Davis-Bacon Act (40 U.S.C. 276a to 276a-7) as supplemented by Department of Labor regulations (29 CFR Part 5). These regulations are herein incorporated by reference in this contract.

4. Contract Work Hours and Safety Standards Act

The Contractor agrees to comply with Sections 103 and 107 of the Contract Work Hours and Safety Standards Act (40 U.S.C. 327-330) as supplemented by Department of Labor regulations (29 CFR Part 5). These regulations are herein incorporated by reference in this contract.

5. Rights to Inventions, Copyrights, and Rights in Data

The Contractor agrees to comply with requirements and regulations pertaining to copyrights and rights in data.

6. Records Access and Retention

The Contractor agrees to grant access by Parish, the State, Federal agencies, the Comptroller General of the United States, or any of their duly authorized representatives to any books, documents, papers, and records of the contractor which are directly pertinent to that specific contract for the purpose of making audit, examination, excerpts, and transcriptions.

The Contractor agrees to retain all required records for three (3) years after final payments have been made and/or all other pending matters are closed.

7. Debarment and Suspension

The Contractor is prohibited from awarding any subcontract expected to equal or exceed \$25,000 to

persons (individuals or organizations) listed on the Excluded Parties List System (EPLS) which is available at www.epls.gov.

8. Energy and Environmental Conservation

The Contractor agrees to comply with mandatory standards and policies relating to energy efficiency which are contained in the state energy conservation plan issued in compliance with the Energy Policy and Conservation Act (Pub. L. 94-163, 89 Stat. 871). [53 FR 8045, 8087, Mar. 11, 1998, as amended at 60 FR 19639, 19641, Apr. 19, 1995; 61 FR 7166, Feb. 26, 1996]. These regulations are herein incorporated by reference in this contract.

9. Reporting

The Contractor agrees to comply with all Federal, State, and Parish requirements and regulations pertaining to reporting on projects receiving Federal, State, or Parish funding.

10. Clean Air and Water Acts

The Contractor agrees to comply with all applicable standards, orders, or requirements issued under section 306 of the Clean Air Act (42 U.S.C. 1857(h)), section 508 of the Clean Water Act (33 U.S.C. 1368), Executive Order 11738, and Environmental Protection Agency regulations (40 CFR Part 15). These regulations are herein incorporated by reference in this contract.

11. Legal Remedies

Contracts must include administrative, contractual, and legal remedies for use in cases in which contractors violate or breach contract terms. The contract must also make clear the remedial actions which you may take.

12. Termination

Contracts in excess of \$10,000 must explain the conditions under which you may terminate them for cause or for your convenience, including the process for bringing about the termination and the basis for settlement.

More information regarding the above provisions can be found on the common drive at the following location:

Y:\Federal Programs Common\FED PROCUREMENT DOCTS\Components\HUD

Federal Aviation Administration (FAA)
49 CFR 18.36

1. Equal Employment Opportunity

The Contractor agrees to comply with Executive Order 11246 of September 24, 1965 entitled "Equal Employment Opportunity," as amended by Executive Order 11375 of October 13, 1967, and as supplemented in Department of Labor regulations (41 CFR Chapter 60).

2. Copeland Anti-Kickback Act

The Contractor agrees to comply with the Copeland "Anti-Kickback" Act (18 U.S.C. 874) as supplemented in Department of Labor regulations (29 CFR Part 3). These regulations are herein incorporated by reference in this contract.

3. Davis Bacon and Related Acts

The Contractor agrees to comply with the Davis-Bacon Act (40 U.S.C. 276a to 276a-7) as supplemented by Department of Labor regulations (29 CFR Part 5). These regulations are herein incorporated by reference in this contract.

4. Contract Work Hours and Safety Standards Act

The Contractor agrees to comply with Sections 103 and 107 of the Contract Work Hours and Safety Standards Act (40 U.S.C. 327-330) as supplemented by Department of Labor regulations (29 CFR Part 5). These regulations are herein incorporated by reference in this contract.

5. Rights to Inventions, Copyrights, and Rights in Data

The Contractor agrees to comply with requirements and regulations pertaining to copyrights and rights in data.

6. Records Access and Retention

The Contractor agrees to grant access by Parish, the State, Federal agencies, the Comptroller General of the United States, or any of their duly authorized representatives to any books, documents, papers, and records of the contractor which are directly pertinent to that specific contract for the purpose of making audit, examination, excerpts, and transcriptions.

The Contractor agrees to retain all required records for three (3) years after final payments have been made and/or all other pending matters are closed.

7. Debarment and Suspension

The Contractor is prohibited from awarding any subcontract expected to equal or exceed \$25,000 to

persons (individuals or organizations) listed on the Excluded Parties List System (EPLS) which is available at www.epls.gov.

8. Energy and Environmental Conservation

The Contractor agrees to comply with mandatory standards and policies relating to energy efficiency which are contained in the state energy conservation plan issued in compliance with the Energy Policy and Conservation Act (Pub. L. 94-163, 89 Stat. 871). [53 FR 8045, 8087, Mar. 11, 1998, as amended at 60 FR 19639, 19641, Apr. 19, 1995; 61 FR 7166, Feb. 26, 1996]. These regulations are herein incorporated by reference in this contract.

9. Reporting

The Contractor agrees to comply with all Federal, State, and Parish requirements and regulations pertaining to reporting on projects receiving Federal, State, or Parish funding.

10. Clean Air and Water Acts

The Contractor agrees to comply with all applicable standards, orders, or requirements issued under section 306 of the Clean Air Act (42 U.S.C. 1857(h)), section 508 of the Clean Water Act (33 U.S.C. 1368), Executive Order 11738, and Environmental Protection Agency regulations (40 CFR Part 15). These regulations are herein incorporated by reference in this contract.

11. UMT Act

The Contractor agrees to comply with Section 3(a)(2)(C) of the UMT Act of 1964, as amended, which prohibits the use of grant or loan funds to support procurements utilizing exclusionary or discriminatory specifications.

12. Cargo Preferences

The Contractor agrees to comply with 46 U.S.C. 1241(b)(1) and 46 CFR part 381 which imposes cargo preference requirements on the shipment of foreign made goods.

13. Buy American

The Contractor agrees to comply with Section 165 of the Surface Transportation Assistance Act of 1992, 49 U.S.C. 1601, section 337 of the Surface Transportation and Uniform Relocation Assistance Act of 1987, and 49 CFR parts 660 and 661 impose Buy America provisions on the procurement of foreign products and materials.

14. Disadvantaged Business Enterprises

The Contractor agrees to comply with Section 105(f) of the Surface Transportation Assistance Act of 1992, section 106(c) of the Surface Transportation and Uniform Relocation Assistance Act of 1987, and 49 CFR part 23 which imposes requirements for the participation of disadvantaged business enterprises.

15. Qualifications-Based Contracts

FAA grantees and subgrantees shall extend the use of qualifications-based contract selection procedures to certain other related areas and shall award such contracts in the same manner as Federal contracts for

architectural and engineering services are negotiated under Title IX of the Federal Property and Administrative Services Act of 1949, or equivalent State (or airport sponsor for FAA) qualifications-based requirements.

16. Legal Remedies

Contracts must include administrative, contractual, and legal remedies for use in cases in which contractors violate or breach contract terms. The contract must also make clear the remedial actions which you may take.

17. Termination

Contracts in excess of \$10,000 must explain the conditions under which you may terminate them for cause or for your convenience, including the process for bringing about the termination and the basis for settlement.

More information regarding the above provisions can be found on the common drive at the following location:

Y:\Federal Programs Common\FED PROCUREMENT DOCTS\Components\FAA

Federal Transit Administration (FTA)

1. Fly America Requirements

49 U.S.C. 40118 and 41 CFR Part 301 - 10

2. Buy America Requirements

49 U.S.C. 5323(j) and 49 CFR Part 661

3. Charter Bus and School Bus Requirements

49 U.S.C. 5323(d) and 49 CFR Part 604, 49 U.S.C. 5323(F) and 49 CFR Part 605

4. Cargo Preference Requirements

46 U.S.C. 1241, 46 CFR Part 381

5. Seismic Safety Requirements

42 U.S.C. 7701 et seq. 49 and CFR Part 41

6. Energy Conservation Requirements

42 U.S.C. 6321 et seq. and 49 CFR Part 18

7. Clean Water Requirements

33 U.S.C. 1251

8. Bus Testing

49 U.S.C. 5318(e)

49 CFR Part 665

9. Pre-Award and Post Delivery Audit Requirements

49 U.S.C. 5323 and 49 CFR Part 663

10. Lobbying

31 U.S.C. 1352 and 49 CFR Parts 19 and 20

11. Access to Records and Reports

49 U.S.C. 5325 and 18 CFR 18.36(i) and 49 CFR 633.17

12. Federal Changes

49 CFR Part 18

13. Bonding Requirements

14. Clean Air

42 U.S.C. 7401 et seq. and 40 CFR 15.61 and 49 CFR Part 18

15. Recycled Products

42 U.S.C. 6962 and 40 CFR Part 247 and Executive Order 12873

16. Davis-Bacon and Copeland Anti-Kickback Acts

17. Contract Work Hours and Safety Standards Act

18. Reserved

19. No Government Obligation to Third Parties

20. Program Fraud and False of Fraudulent Statements and Related Acts.

31 U.S.C. 3801 et seq. and 49 CFR Part 31 18 U.S.C. 1001 and 49 U.S.C. 5307

21. Termination

49 U.S.C. Part 18 and FTA Circular 4220.1E

22. Government-Wide Debarment and Suspension (Non-procurement)

49 CFR Part 29 and Executive Order 12549

23. Privacy Act

5 U.S.C. 552

24. Civil Rights Requirements

29 U.S.C. 623, 42 U.S.C. 2000, 42 U.S.C. 6102, 42 U.S.C. 12112, 42 U.S.C. 12132, 49 U.S.C. 5332, 29 CFR Part 1630 and 41 CFR Parts 60 et seq.

25. Breaches and Dispute Resolution

49 CFR Part 18, FTA Circular 4220.1E

26. Patent and Rights Data

37 CFR Part 401 and 49 CFR Parts 18 and 19

27. Transit Employee Protective Agreements

49 U.S.C. 5310, 5311, and 5333, 29 CFR Part 215

28. Disadvantaged Business Enterprises (DBE)

49 CFR Part 26

29. Reserved

30. Incorporation of Federal Transit Administration (FTA) Terms

FTA Circular 4220.1E

31. Drug and Alcohol Testing

49 U.S.C. 5331 and 49 CFR Parts 653 and 654

A detailed guide regarding the above provisions can be found on the common drive at the following location:

Y:\Federal Programs Common\FED PROCUREMENT DOCTS\Components\FTA

Department of the Interior (DOI) (GOMESA) 30 CFR 1219.410

1. Equal Employment Opportunity

The Contractor agrees to comply with Executive Order 11246 of September 24, 1965 entitled “Equal Employment Opportunity,” as amended by Executive Order 11375 of October 13, 1967, and as supplemented in Department of Labor regulations (41 CFR Chapter 60).

2. Copeland Anti-Kickback Act

The Contractor agrees to comply with the Copeland “Anti-Kickback” Act (18 U.S.C. 874) as supplemented in Department of Labor regulations (29 CFR Part 3). These regulations are herein incorporated by reference in this contract.

3. Davis Bacon and Related Acts

The Contractor agrees to comply with the Davis-Bacon Act (40 U.S.C. 276a to 276a-7) as supplemented by Department of Labor regulations (29 CFR Part 5). These regulations are herein incorporated by reference in this contract.

4. Contract Work Hours and Safety Standards Act

The Contractor agrees to comply with Sections 103 and 107 of the Contract Work Hours and Safety Standards Act (40 U.S.C. 327-330) as supplemented by Department of Labor regulations (29 CFR Part 5). These regulations are herein incorporated by reference in this contract.

5. Rights to Inventions, Copyrights, and Rights in Data

The Contractor agrees to comply with requirements and regulations pertaining to copyrights and rights in data.

6. Records Access and Retention

The Contractor agrees to grant access by Parish, the State, Federal agencies, the Comptroller General of the United States, or any of their duly authorized representatives to any books, documents, papers, and records of the contractor which are directly pertinent to that specific contract for the purpose of making audit, examination, excerpts, and transcriptions.

The Contractor agrees to retain all required records for three (3) years after final payments have been

made and/or all other pending matters are closed.

7. Debarment and Suspension

The Contractor is prohibited from awarding any subcontract expected to equal or exceed \$25,000 to persons (individuals or organizations) listed on the Excluded Parties List System (EPLS) which is available at www.epls.gov.

8. Energy and Environmental Conservation

The Contractor agrees to comply with mandatory standards and policies relating to energy efficiency which are contained in the state energy conservation plan issued in compliance with the Energy Policy and Conservation Act (Pub. L. 94-163, 89 Stat. 871). [53 FR 8045, 8087, Mar. 11, 1998, as amended at 60 FR 19639, 19641, Apr. 19, 1995; 61 FR 7166, Feb. 26, 1996]. These regulations are herein incorporated by reference in this contract.

9. Reporting

The Contractor agrees to comply with all Federal, State, and Parish requirements and regulations pertaining to reporting on projects receiving Federal, State, or Parish funding.

10. Clean Air and Water Acts

The Contractor agrees to comply with all applicable standards, orders, or requirements issued under section 306 of the Clean Air Act (42 U.S.C. 1857(h)), section 508 of the Clean Water Act (33 U.S.C. 1368), Executive Order 11738, and Environmental Protection Agency regulations (40 CFR Part 15). These regulations are herein incorporated by reference in this contract.

11. Legal Remedies

Contracts must include administrative, contractual, and legal remedies for use in cases in which contractors violate or breach contract terms. The contract must also make clear the remedial actions which you may take.

12. Termination

Contracts in excess of \$10,000 must explain the conditions under which you may terminate them for cause or for your convenience, including the process for bringing about the termination and the basis for settlement.

13. Release of Funds

The Contractor agrees that no award, or execution of contract, or Notice to Proceed, will occur until a Release of Funds is issued by HUD for CDBG-DR Disaster Recovery funds.

14. Section 3

The Contractor agrees to comply with all applicable standards, orders, or requirements issued under Section 3 of the Housing and Urban Development Act of 1968, as amended, 12 U.S.C. 1701u (section 3).