



STATE OF LOUISIANA  
DEPARTMENT OF TRANSPORTATION AND DEVELOPMENT  
TECHNICAL SPECIFICATIONS FOR

**TRUCK, CAB & CHASSIS, 33,000# GVWR, ASPHALT DISTRIBUTOR**

**SERIES NO. 215-000**  
**EQUIPMENT SPECIFICATION 215-000A**

**REV. 5/22/2024**

**GENERAL**

This specification sets forth the minimum requirements for a truck, cab & chassis, 33,000# GVWR with a truck mounted asphalt distributor.

Equipment shall be new, a production model of current manufacture, and must meet all state and Federal safety and emission standards in effect at time of order.

**REPRESENTATIVE SPECIFICATIONS**

An International MV607 or Freightliner M2-106 chassis with an Etnyre or Leeboy asphalt distributor system. All the appropriate options and standard features were used to develop these specifications and establish equivalency evaluation criteria.

Equipment of similar style, type, character, quality, features, and purpose conforming to the following detailed requirements/specifications will be considered. For evaluation purposes, bidders proposing an exception/equivalent option/feature to those specified herein, may be required to provide manufacturer/product information (catalogue sheets, detailed specifications, pictures, etc.). This information will be evaluated against the minimum requirements of this specification. Proposed submittals that are determined not to be equivalent to the established criteria will be rejected.

**LOUISIANA AUTHORIZED DEALER(S)**

Proposed item(s) must be from a manufacturer who has at least one (1) authorized dealer within the State of Louisiana where parts and service can be obtained. Authorized dealer(s) must have properly trained technicians plus all other resources necessary to perform warranty and repair services in complete accordance with the manufacturer's requirements. A letter certifying the ability to meet this requirement, inclusive of the company name(s) and address(es) of the Louisiana authorized dealer(s), should be supplied with the bid submittal and may be required prior to award.

**DELIVERY & ACCEPTANCE**

Vendor shall perform a test run of each unit to verify that all features and capabilities are operating properly at time of delivery. Documentation of testing may be required prior to acceptance by the Department.

Unit(s) must be delivered completely assembled (including all components, accessories, etc.) and ready for operation without any additional preparation including, but not limited to, ensuring all fluid levels are at their full mark, fuel tank(s) is full, all necessary lubrication has been performed, etc. A Louisiana safety inspection shall be performed on each vehicle prior to delivery and a Louisiana safety inspection sticker properly affixed.

Any unit delivered under this specification is subject to rejection if there is evidence of poor workmanship, by either the vendor or the original manufacturer. Noted defects and/or nonconformance findings may



be corrected by the vendor. Corrections must be completed and approved by the Equipment Engineer or his representative prior to final acceptance.

Unit(s) shall be delivered "**on the ground**;" DOTD will not unload nor provide any unloading equipment to the vendor/delivery driver in order to offload the unit(s).

**NOTE:** The Department will have space available for equipment to be unloaded.

**EACH UNIT MUST BE SUPPLIED WITH THE FOLLOWING DOCUMENTATION AT TIME OF DELIVERY:**

1. Notarized Bill of Sale
2. Original Certificate of Origin (MSO), (no photocopy)
3. Dealer's Service Policy
4. Owner's/Operator's Manual(s)
  - a. One (1) Hardcopy
  - b. One (1) Digital Copy
    - i. Acceptable Formats: PDF delivered via USB "Flash Drive", or E-mail
5. Service Manual(s)
  - a. One (1) Hardcopy
  - b. One (1) Digital Copy
    - i. Acceptable Formats: PDF delivered via USB "Flash Drive", or E-mail
6. Build Sheet(s) – as applicable
  - a. One (1) Hardcopy
  - b. Build sheets should be written in plain language (not company specific codes) and include, at a minimum, all standard & optional features of the delivered unit.

**NOTE:** Invoices will not be processed for payment until the unit(s) have been inspected by the Equipment Engineer or their representative and deemed in compliance with the specifications.

**BID SUBMITTALS**

Any additions, deletions, or variations from the specifications should be noted in the "Bidder's Exceptions" page of this specification. Exceptions that are noted to be less than a minimum requirement will not be accepted.

Any additions, deletions or variations from the manufacturer's standard published specifications should be noted on the "Bidder's Exceptions" page of this specification. Unless otherwise noted, any items appearing in the manufacturer's standard published specifications furnished by the Bidder are assumed to be included in the Bidder's submittal.

Bidder should note on their submittal any installation(s) to the equipment that will be performed by the vendor instead of the manufacturer.

Failure to note any specification exceptions, manufacturer specification alterations, and/or vendor installations prior to award may result in rejection of the equipment at the time of delivery.

**THE NUMBER OF DELIVERY DAYS AFTER RECEIPT OF ORDER (ARO) MAY BE USED AS A FACTOR IN THE AWARD.**

## EQUIPMENT SPECIFICATIONS

### NOTICE TO BIDDERS

Bidder should review the detailed "Equipment Specification" completely and respond to the compliance question at the end of each section by marking "X", in the space provided, for "Yes" or "No". Mark "Yes" to indicate that the equipment bid meets the section exactly as specified. Mark "No" if there are exceptions to any part of that section. Exceptions/deviations to any part of the specification are to be detailed on the "Bidder's Exceptions" page of this specification.

IN ORDER TO BE CONSIDERED FOR AWARD, BIDDER SHOULD RETURN THIS SPECIFICATION, COMPLETED IN FULL, WITH THEIR BID SUBMITTAL.

**Note: All values listed below are minimums unless noted otherwise.**

#### 1. Cab & Chassis

1.1. GVWR: 33,000 lbs.

Comply:  Yes  No

1.2. Frame: 1,400,000 RBM (Resisting Bending Moment) - Bidder should list section modulus and yield strength below

Section Modulus: \_\_\_\_\_ Yield Strength: \_\_\_\_\_

Comply:  Yes  No

#### 1.3. Cab & Axle Positions

1.3.1. Front axle: For the purposes of this solicitation, set-forward-axle (SFA) is considered equal to set-back-axle (SBA); however, SBA is the preferred option

1.3.2. Wheelbase: 180"

1.3.3. Cab to Axle (CA): 114" clear

1.3.4. Values given here are minimums. Truck vendor and Asphalt Distributor manufacturer shall coordinate in selecting a wheelbase and cab to axle dimension that is compatible with the required body length and ensures proper load distribution to the axles in accordance with manufacturer and industry practice.

Comply:  Yes  No

#### 1.4. Front Bumper

1.4.1. Full width all-steel front bumper

1.4.2. Two (2) frame mounted tow hooks, one on each frame rail

Comply:  Yes  No

#### 1.5. Cab

1.5.1. Conventional day cab

1.5.2. Tinted safety glass

## EQUIPMENT SPECIFICATIONS

- 1.5.3. Cab entry handles, driver & passenger side
- 1.5.4. Outside mirrors, driver & passenger side
  - 1.5.4.1. Power adjustable
  - 1.5.4.2. 90 sq. in. minimum
  - 1.5.4.3. Heated
  - 1.5.4.4. Two (2) adjustable spot mirrors, one (1) per outside mirror
- 1.5.5. One (1) standard electric horn
- 1.5.6. Air cab suspension
- 1.5.7. Driver seat to be high back with lumbar support and air suspension
- 1.5.8. Wing dash, if available
- 1.5.9. Gauge package including the following gauges:
  - 1.5.9.1. Air cleaner restriction
  - 1.5.9.2. Coolant temperature
  - 1.5.9.3. Fuel
  - 1.5.9.4. Oil pressure
  - 1.5.9.5. Primary and secondary air pressure
  - 1.5.9.6. Speedometer
  - 1.5.9.7. Tachometer
  - 1.5.9.8. Voltmeter
  - 1.5.9.9. Gear indicator
  - 1.5.9.10. Odometer
  - 1.5.9.11. Total engine hours
  - 1.5.9.12. Trip hours
  - 1.5.9.13. Trip odometer
  - 1.5.9.14. Rear axle oil temperature
  - 1.5.9.15. Auto transmission oil temperature
- 1.5.10. Dual sun visors
- 1.5.11. Two (2) cup holders, integral to dash
- 1.5.12. 3-point seat belt for each seat
- 1.5.13. Climate control, including air conditioning, heater, & defroster
- 1.5.14. Power windows & power door locks
- 1.5.15. Tilting and telescoping steering wheel

Comply:  Yes  No

- 1.6. Engine
  - 1.6.1. 6.7L, electronic diesel, turbocharged, liquid cooled, 6-cylinder inline configuration
  - 1.6.2. 250 HP
  - 1.6.3. Engine must include compression/turbo exhaust brake
  - 1.6.4. Emission system must comply with emission standards in effect as of date manufactured
  - 1.6.5. DEF tank to be located on driver's side next to fuel tank
  - 1.6.6. DEF tank must have a minimum capacity of 6 gallons
  - 1.6.7. Engine must be biodiesel compatible

## EQUIPMENT SPECIFICATIONS

**1.6.8.** Horizontal exhaust after-treatment (DPF) with horizontal tail pipe

**Comply:** \_\_\_ Yes \_\_\_ No

### **1.7.** Fuel System

**1.7.1.** Fuel tank shall be metal with drain and a 50-gallon minimum capacity; tank should be located on driver's side

**1.7.2.** Davco fuel processor or equal - mounted to outside of frame

**1.7.3.** Visual element change indication that is integral to and non-removable from unit (to be located on driver's side near fuel tank)

**1.7.4.** Water-in-fuel sensor with indicator in cab

**1.7.5.** Entire fuel system must be biodiesel compatible

**Comply:** \_\_\_ Yes \_\_\_ No

### **1.8.** Transmission

**1.8.1.** Automatic, Allison 3500 RDS with PTO provision

**1.8.2.** Must include PTO aperture

**1.8.3.** To be filled with manufacturer approved synthetic lubricants

**Comply:** \_\_\_ Yes \_\_\_ No

### **1.9.** Gearing, Speed Governing & Performance

**1.9.1.** Top gear road speed shall be electronically governed at 75 mph maximum

**1.9.2.** Cruise control speed shall be governed at 75 mph maximum

**1.9.3.** Transmission and axle ratio shall be selected for performance to be optimized at 65 while permitting truck to operate up to 75 MPH on highway without excessive engine speed. Transmission and axle ratio shall also allow truck to accomplish 0.5 to 1.5 MPH forward speed at approximately 1200 RPM engine speed

**Comply:** \_\_\_ Yes \_\_\_ No

### **1.10.** PTO

**1.10.1.** PTO with pump that meets requirements of the spray unit mounted to truck

**1.10.2.** PTO must be air or electric shifted and compatible with specified transmission

**1.10.3.** PTO must be activated by dash mounted upfitter switch

**Comply:** \_\_\_ Yes \_\_\_ No

### **1.11.** Front Axle

**1.11.1.** 10,000 lbs. GAWR @ ground capacity

**1.11.2.** Shock absorbers

**1.11.3.** Integral power steering

**1.11.4.** Wet-type, visible cap axle seals, Stemco or equal

## EQUIPMENT SPECIFICATIONS

**1.11.5.** Axle should be filled with manufacturer approved synthetic lubricants

**Comply:** \_\_\_ Yes \_\_\_ No

**1.12.** Rear Axle

**1.12.1.** Single speed, 23,000 lbs. GAWR @ ground capacity

**1.12.2.** Multi-leaf spring suspension

**1.12.3.** Axle should be filled with manufacturer approved synthetic lubricants

**Comply:** \_\_\_ Yes \_\_\_ No

**1.13.** Brakes

**1.13.1.** Air brake system, ABS brake system with traction control

**1.13.2.** 18 CFM air compressor

**1.13.3.** Bendix AD-9 air dryer or equal

**Comply:** \_\_\_ Yes \_\_\_ No

**1.14.** Wheels & Tires

**1.14.1.** Hub piloted steel disc, size - 8.25 X 22.5

**1.14.2.** First line, first quality tires, size – 11R22.5

**1.14.3.** Radial front and rear tires

**1.14.4.** Load ratings to be compatible with GVWR

**Comply:** \_\_\_ Yes \_\_\_ No

**1.15.** Electrical System & Lights

**1.15.1.** 12-volt system

**1.15.2.** 160-amp brushless alternator

**1.15.3.** Batteries with 2000 CCA combined, maintenance free, top threaded stud

**1.15.4.** Battery box with cover

**1.15.5.** Remote jump start studs, with tethered protective caps, located outside of the battery box

**1.15.6.** Battery disconnect switch, located inside cab, near driver's seat, similar to the below picture.



**1.15.7.** Battery discharge protection

**1.15.8.** Headlights: automatic daytime running lights

**1.15.9.** Cruise control

## EQUIPMENT SPECIFICATIONS

- 1.15.10. Intermittent windshield wipers with washers
- 1.15.11. Self-cancelling directional signals
- 1.15.12. Backup alarm, 97 dba
- 1.15.13. AM/FM/WB radio with auxiliary front input, Bluetooth/hands free function and steering wheel controls
- 1.15.14. Two (2) 12V accessory power outlets with covers, mounted in dash (for cell phone chargers, GPS devices, etc.)

Comply:  Yes  No

### 1.16. Paint

- 1.16.1. Cab: Manufacturer's standard
- 1.16.2. Chassis: Manufacturer's standard black

Comply:  Yes  No

### 1.17. FMCSA/DOT Mandated Safety Items

- 1.17.1. One (1) UL listed, 5 B:C rated, or higher, fire extinguisher securely mounted in cab
- 1.17.2. One (1) set of three (3) bidirectional reflective triangles conforming to FMVSS No. 125
- 1.17.3. At least one (1) spare fuse for each type/size used in the truck

Comply:  Yes  No

**Note: The truck vendor and attached equipment manufacturer/vendor must mutually resolve any unexpected truck/attached equipment component conflict with a sound and functional solution as a requirement of this specification.**

## 2. Asphalt Distributor

### 2.1. General

- 2.1.1. Truck mounted distributor
- 2.1.2. 2000 gallon capacity tank
- 2.1.3. Hydraulically driven pump system
- 2.1.4. In-cab computer with controls for one person operation
- 2.1.5. LPG heating system with two (2) U-type return flues
- 2.1.6. Pump system capable of pumping a minimum of 400 gallons/minute (GPM)
- 2.1.7. Distributor shall use volumetric metering with no bypass when spraying
- 2.1.8. Distributor shall be equipped with air controls for the spray and circulating system

Comply:  Yes  No

### 2.2. Tank

- 2.2.1. Tank design and construction to meet all applicable Federal Tank Regulations with consideration for hot asphalt products. Tank must have ASME approval number

## EQUIPMENT SPECIFICATIONS

- 2.2.2. 2000 gallon capacity
- 2.2.3. Oval cross section design
- 2.2.4. Tank shell to be ten (10) gauge steel
- 2.2.5. Tank heads to be ten (10) gauge steel
- 2.2.6. Flanged reinforced and welded to tank shell both inside and outside
- 2.2.7. Full section surge plate
  - 2.2.7.1. Constructed of 10 gauge steel
  - 2.2.7.2. Surge plate shall have openings for access and proper surge control
- 2.2.8. Manhole with a minimum 20" inside diameter with quick opening cover and strainer
- 2.2.9. Overflow
  - 2.2.9.1. Minimum of 3 inch in diameter
  - 2.2.9.2. Overflow to drain internally through the bottom of the tank
- 2.2.10. Tank Insulation
  - 2.2.10.1. 2 inch insulation with spacers to prevent compression
  - 2.2.10.2. Insulation protected by aluminum jacket
- 2.2.11. Tank to be mounted on saddles which are full bolster style
- 2.2.12. Tank gauge
  - 2.2.12.1. Float type
  - 2.2.12.2. Tank shall have two (2) gauges located on front and rear of tank
- 2.2.13. Tank shall include refiners platform and ladder
- 2.2.14. Tank to have 4 inch dial thermometers

Comply: \_\_\_ Yes \_\_\_ No

### 2.3. Heating System

- 2.3.1. Liquid petroleum gas (LPG) heat system
  - 2.3.1.1. Include pressure regulator, valves and piping
  - 2.3.1.2. Include a 48 gallon tank mounted on the frame
- 2.3.2. Heating system to be two flue style
- 2.3.3. Flues to be U-shaped running the full length of the tank
- 2.3.4. Inlet and exhaust opening of each flue to be in the same horizontal plane
- 2.3.5. Flues to have stainless steel external stack

Comply: \_\_\_ Yes \_\_\_ No

### 2.4. Power Unit

- 2.4.1. Hydrostatic pump driven by truck PTO
  - 2.4.1.1. Infinitely variable displacement pump
  - 2.4.1.2. Electronic stroker control
  - 2.4.1.3. Axial piston type
- 2.4.2. Hydraulic oil cooler for hydraulic system
- 2.4.3. Motor
  - 2.4.3.1. Piston motor with gearbox
  - 2.4.3.2. Motor to asphalt pump connection – direct coupled
  - 2.4.3.3. Maximum operating temperature – 200 degrees



## EQUIPMENT SPECIFICATIONS

**2.4.3.4.** To be fitted with relief valve

**2.4.3.5.** High hydraulic oil temperature signal in cab of truck

Comply: \_\_\_ Yes \_\_\_ No

### 2.5. Hydraulic Lines and Hoses

**2.5.1.** Line and Hose installation to be made according to manufacturer's recommendations

**2.5.2.** A 10 micron replaceable cartridge filter with vacuum gauge shall be located in the line between oil reservoir and hydrostatic pump

Comply: \_\_\_ Yes \_\_\_ No

### 2.6. Hydrostatic System Controls

**2.6.1.** In truck cab electronic micro-control of hydrostatic system to allow for setting of asphalt pump discharge rate

**2.6.2.** Hydraulic solenoid valves to be ground accessible

**2.6.3.** Control capable of stopping the variable pump discharge without disconnecting drive

**2.6.4.** Override of the micro-control to allow increases in asphalt pump output for filling, sucking back, etc.

**2.6.5.** Override shall not affect application rate setting

**2.6.6.** Override shall be located at rear of unit

Comply: \_\_\_ Yes \_\_\_ No

### 2.7. Hydraulic Reservoir

**2.7.1.** Minimum 20 gallon hydraulic oil reservoir

**2.7.2.** Reservoir to have temperature indicator on reservoir

**2.7.3.** Reservoir to have level indicator on reservoir

Comply: \_\_\_ Yes \_\_\_ No

### 2.8. Asphalt Pump

**2.8.1.** Asphalt pump to be a positive displacement rotary gear type

**2.8.2.** Mounted below the bottom level of tank

**2.8.3.** Pump must be capable of complete drainage when tank valve is closed

**2.8.4.** Minimum capacity of pump to be 400 GPM (gallons per minute)

**2.8.5.** Asphalt control valve

**2.8.5.1.** Single 4-way cast plug type

**2.8.5.2.** Bolt directly to bottom of asphalt pump

**2.8.5.3.** Controlled by in-cab controls

Comply: \_\_\_ Yes \_\_\_ No

### 2.9. Spray Bar

**2.9.1.** Variable width spray bar up to 16 feet

**2.9.2.** Spray bar to be full circulating

## EQUIPMENT SPECIFICATIONS

- 2.9.3. Cab controls for to allow for 1 foot spray width control
- 2.9.4. Cab controlled functions of spray bar
- 2.9.5. Nozzles to be spaced on 4 inch centers on spray bar
- 2.9.6. Individual valve for each spray nozzle with flip lever control for spray width adjustment
- 2.9.7. Swivel joints to be O-ring seal type
- 2.9.8. Spray bar to have safety breakaway
- 2.9.9. Spray bar to adjust for positive or negative crown
- 2.9.10. Powered spray bar latch with controls on rear of distributor and in-cab control
- 2.9.11. Tank suction valve
  - 2.9.11.1. Valve to be located at bottom of tank
  - 2.9.11.2. Valve to be air control open, spring close

Comply: \_\_\_ Yes \_\_\_ No

### 2.10. Air Controls

- 2.10.1. Distributor shall be equipped with air controls
- 2.10.2. Air system on truck shall supply air for controls
- 2.10.3. Distributor air system shall have an air tank separate from truck chassis
- 2.10.4. Distributor air system shall have safety valve set at eighty (80) PSI to protect truck chassis air supply
- 2.10.5. Distributor air system to have air-line oiling and water separator device separate from truck air system
- 2.10.6. Air solenoid valves to be mounted to be accessible from the ground

Comply: \_\_\_ Yes \_\_\_ No

### 2.11. Controls/ Instrumentation

- 2.11.1. Computer with in-cab controls
  - 2.11.1.1. Computer shall allow a minimum of 10 preset application rates
  - 2.11.1.2. Distance/ volume reset switch
  - 2.11.1.3. Application rate adjustment switch
  - 2.11.1.4. Display select switch
- 2.11.2. Instrumentation in-cab shall allow for the following data to be displayed
  - 2.11.2.1. Truck travel speed in feet/minute
  - 2.11.2.2. Application rate in gallons/ square yard
  - 2.11.2.3. Pump rate in gallons/minute
  - 2.11.2.4. Resettable distance sprayed in feet
  - 2.11.2.5. Resettable volume sprayed in gallons
  - 2.11.2.6. Low tank level warning
  - 2.11.2.7. Travel speed and/or supplication rates beyond system capability alarm
  - 2.11.2.8. Liquid asphalt temperature digital display on in-cab computer display
- 2.11.3. Radar type sensor to sense ground speed
- 2.11.4. 4 way asphalt valve control by in-cab system

Comply: \_\_\_ Yes \_\_\_ No

## EQUIPMENT SPECIFICATIONS

### 2.12. Accessories

- 2.12.1. Wash down system with pump and hose
- 2.12.2. Hand spray wand with 25 ft. rubber hose
- 2.12.3. Hose trough for fill hose
- 2.12.4. Liquid sampling valve located in rear tank head
- 2.12.5. Minimum of three (3) nozzles for hand spray gun
- 2.12.6. All liquid asphalt pumped to the tank, from the tank or to the spray bar must pass through a screen
- 2.12.7. Turn signals at rear of distributor controlled by truck chassis
- 2.12.8. Rear bumper with lights and reflectors
  - 2.12.8.1. Distributor lights to be sealed L.E.D. type
  - 2.12.8.2. See section 3. **Safety Lighting** for additional lighting
- 2.12.9. All required tools shall be supplied with distributor

Comply: \_\_\_ Yes \_\_\_ No

### 2.13. Body Installation

- 2.13.1. A sill spacer is not required. A rubber or plastic (Nylon or Delrin) sill spacer may be used between the chassis frame and body subframe. WOOD SPACERS ARE NOT ALLOWED!
- 2.13.2. Body shall be bolted to frame using brackets or fishplates, similar to below. U-BOLTS ARE NOT ALLOWED!
  - 2.13.2.1. Where possible, the upfitter should use existing holes in the chassis frame web.
  - 2.13.2.2. Brackets

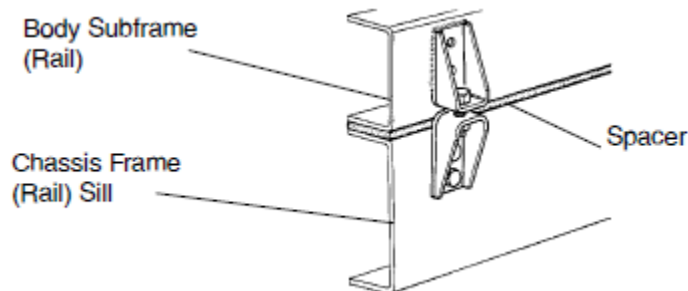

- 2.13.2.3. Fishplates – To be bolted to chassis frame and bolted or welded to body subframe

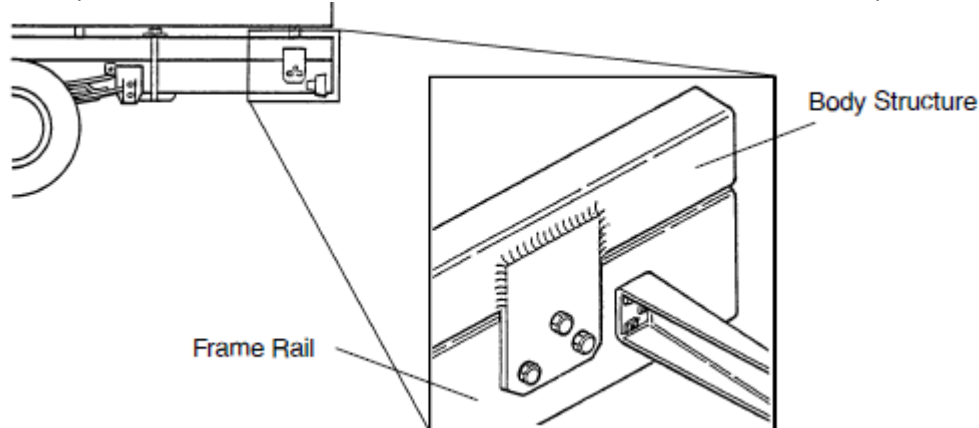

Comply: \_\_\_ Yes \_\_\_ No

## EQUIPMENT SPECIFICATIONS

**2.14.** Paint: Distributor steel components shall be finished in manufacturers standard black enamel

**Comply:** \_\_\_ Yes \_\_\_ No

### 3. Safety Lighting

- 3.1.** Truck must be delivered with warning lights installed in accordance with these specifications and the illustrated layout below
- 3.2.** Warning lights shall be installed by an upfitter who is experienced in and regularly engages in the installation of automotive electronics & warning lights. Installer shall use vehicle & lighting manufacturers' guidance along with industry best practices and techniques to ensure that lights are installed in a safe and neat manner
- 3.3.** All wiring and cables should be logically routed, secured, and protected with convoluted loom where possible. Rubber grommets shall be used where wires and cables penetrate any cab panels, body panels, or chassis structure. All cab and body penetrations shall be adequately sealed to prevent water from entering.
- 3.4.** All warning lights must be controlled by a single in-cab, dash-mounted upfitter switch. The switch must be labeled to read "Warning Lights".
- 3.5.** Installer must contact the DOTD Equipment Section prior to programming to confirm intended flash pattern(s).
- 3.6.** Full size Light Bar – Full (60") light bar that satisfies the following requirements, mounted to the cab and not interfering with air horns (see picture below)
  - 3.6.1.** SoundOff Signal nRoads Mid-Size or equal
  - 3.6.2.** Length is nominal and +/- 1" is acceptable.
  - 3.6.3.** Dual color - 12 diodes per module (equal number of green & amber)
  - 3.6.4.** All pods/modules must be capable of fully displaying both colors.
  - 3.6.5.** Flash pattern must be capable of alternating between an asymmetric, low frequency, "wig-wag" pattern and a low-frequency double or quad flash.
  - 3.6.6.** UV resistant clear polycarbonate lens
  - 3.6.7.** 10-16 VDC
  - 3.6.8.** Light bars shall meet all applicable federal/state laws and regulations
  - 3.6.9.** Shall be SAE J845 360-degree Class 1 certified
- 3.7.** Perimeter Lights - Four (4) perimeter lights, front mounted at grill level (see picture below)
  - 3.7.1.** Brooking Industries M16 surface mount perimeter lighthouse or equal
  - 3.7.2.** Size: Length: 4.5-5.5 in., Height: 1.0-2.0 in., Depth: 0.3-0.5 in.
  - 3.7.3.** 12-24 VDC
  - 3.7.4.** UV resistant clear polycarbonate lens, black bezel trim
  - 3.7.5.** Sixteen (16) diodes, dual color, equal number of green & amber (interleaved 8x8)
  - 3.7.6.** Lighthouse must be capable of displaying each color across full length
  - 3.7.7.** Capable of alternating between an asymmetric, low frequency, "wig-wag" pattern and a low-frequency double or quad flash
  - 3.7.8.** Lighthouse shall meet all applicable federal/state laws and regulations
  - 3.7.9.** Shall be SAE J595 Class 1 certified
- 3.8.** Two (2) 6" rear facing oval lights mounted in rear. (See picture below)
  - 3.8.1.** 6" L x 2 1/4" W , recessed, grommet, snap-in mount, LED
  - 3.8.2.** Polycarbonate lens
  - 3.8.3.** Dual color – half-amber, half-green
  - 3.8.4.** Must be capable of double or quad flash pattern

## EQUIPMENT SPECIFICATIONS

**3.8.5.** 12-24 VDC, with plug-in connector

**3.8.6.** Shall be SAE J595 Class 2 certified



Comply: \_\_\_ Yes \_\_\_ No

### 4. Manuals/Training

**4.1.1.** The supplier shall provide one printed version and one electronic version of the Operators' manual for the truck.

**4.1.2.** The supplier shall provide one printed version and one electronic version of the Operators' manual for the Asphalt Distributor bed.

**4.1.3.** The supplier shall provide one printed version and one electronic version of the parts manual for the Asphalt Distributor bed.

**4.1.4.** Installation shall be completed at the supplier's location. It shall be the responsibility of the supplier to insure that all unit items are properly located and installed.

Comply: \_\_\_ Yes \_\_\_ No

